

OWNER'S MANUAL

Model: 110-3PT-17N (5303082)

(110 Gallon 3-Point Sprayer w/8-Row Boom, Handgun, Pump & Coupler)

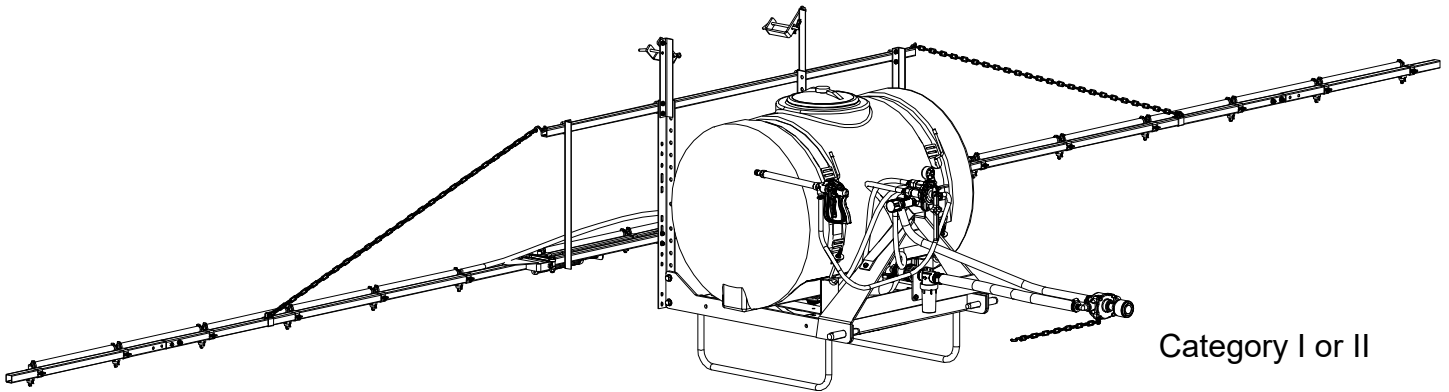

Category I or II

General Information

Thank you for purchasing this product. The purpose of this manual is to assist you in operating and maintaining your 3 Point sprayer.

**BEFORE RETURNING THIS PRODUCT
FOR ANY REASON, PLEASE CALL**

1-800-831-0027

MONDAY-FRIDAY, 8:00 AM TO 5:00 PM CST

If you should have a question or experience a problem with your Fimco Industries Product: Visit our website @ www.fimcoindustries.com or call the Toll free number above. Our technical support representatives will be happy to help you.

In most cases a customer service rep. can resolve the problem over the phone.

To obtain prompt, efficient service, always remember to give the following information....

- Correct Part Description and/or part number
- Model number and Serial Number

Part descriptions and numbers can be obtained from the illustrated parts list section(s) of this manual.



WARNING: Cancer and Reproductive Harm.
www.P65Warnings.ca.gov



WARNING: To reduce the risk of injury, the user must read and understand the operator's manual before using this product.



www.fimcoindustries.com

1000 FIMCO Lane, P.O. Box 1700, North Sioux City, SD 57049
Toll Free Phone: 800-831-0027 : Toll Free Fax: 800-494-0440
[5195385 (10/22)]

Retain a copy of your receipt for your unit, as it will be required to validate any warranty service.

Warranted against manufacturer or workmanship defects from date of purchase with copy of receipt:

**Homeowner Usage: One Year
Commercial Usage: 90 Days.**

Contents

Technical Specs.....	2	Roller Pump Exploded View/Parts List.....	12
Sprayer and Boom Assembly Instructions.....	3 - 5	Roller Pump Gen. Info/Operations/Maintenance.....	13
Sprayer Info	5	Roller Pump Troubleshooting	14
Operation and Calibration.....	6	Pressure Relief Valve Exploded View/Parts List.....	14
Maintenance, Tank Care and Winter Storage	7	TeeValve Control Valve Info.....	14
Sprayer Exploded View.....	8	Sprayer Dimensions	15
Sprayer Parts List.....	9	Troubleshooting.....	15
Boom Exploded View and Parts Lists.....	9 - 11	Warranty.....	16
High Pressure Spray Gun Info.....	12		

Model: 110-3PT-17N (5303082) (110 Gallon 3-Point Sprayer w/8-Row Boom, Handgun, Pump & Coupler)

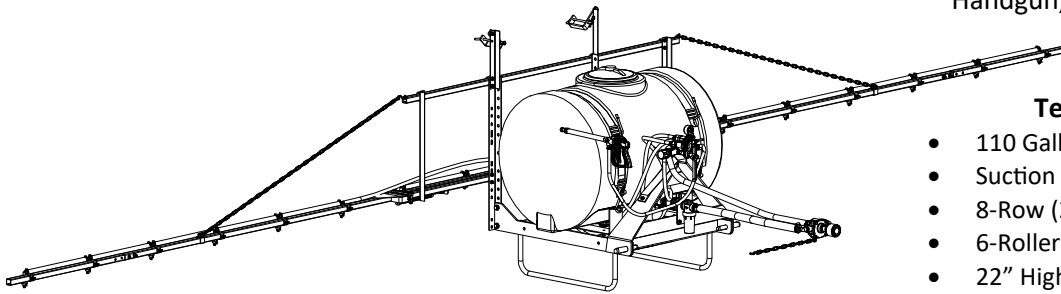

Technical Specifications

- 110 Gallon Polyethylene Tank
- Suction Line Filter
- 8-Row (28') Boom
- 6-Roller Pump & Coupler
- 22" High Pressure Spray Gun

**Caution: When fully filled with water, this sprayer will weigh approx. 1,255 lbs..
Consult the owner's manual for your vehicle to verify that you are within it's load carrying capacity.**

~~~~~IMPORTANT~~~~~

Remove tank lid and be sure the tank is clean and free of any foreign material. Rinse tank out of any tank residue before filling with water to test.

~~~~~IMPORTANT~~~~~

It is VERY important to test this sprayer with plain water before actual spraying is attempted. This will enable you to check the sprayer for leaks without the possibility of losing any expensive chemicals.

~~~~~WARNING~~~~~



Read and Understand the Owner's Manual before using this sprayer. Test and use in accordance to instructions.
Read and Follow chemical label instructions and wear protective gear when filling, using, cleaning and servicing the sprayer.

Exercise Caution in vehicle handling when towing/hauling a filled sprayer to avoid loss of control or overturning.

Keep Sprayer and Spray materials away from other people, children and pets.

Do Not Turn on Power to the sprayer, until ready to spray in order to avoid unintentional spray release.

Do Not Use on steep slopes. A full sprayer could cause loss of control or overturn sprayer and vehicle.

Always operate up and down a slope, never across the face of a slope.

Keep all movement on slopes slow and gradual. Do not make sudden changes in speed, directions or turning. Do not start or stop suddenly when going uphill or downhill.

Stop on level ground, set the parking brake and shut off engine before leaving the operator's position for any reason.

Keep all parts in good condition and properly installed. Fix damaged or worn parts immediately.

Caution should be taken when towing and/or using any sprayer. This sprayer combined with the weight distribution, turning radius and speed of vehicle can result in damage to vehicle and/or sprayer or severe injury or death, if not used properly.

Improper use of this sprayer or handling of chemicals could result in serious injury or illness, or could cause damage to the environment.

Assembly Procedure

Most of the sprayer has been assembled at the factory.

- Follow the steps on pages 3, 4 & 5 to properly assemble the sprayer.

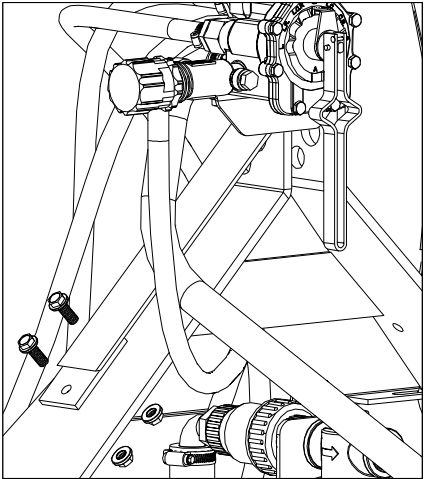

1. Install the preassembled tee valve sub-assembly to the 3-point carrier valve mount and position as shown.

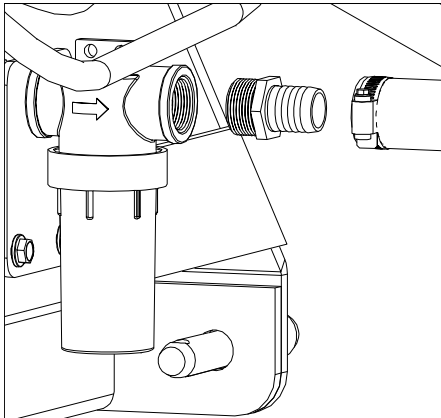

3. Using a good quality thread sealant, carefully thread the 1" fitting into the strainer. Find the 1" x 36" pump feeder hose. Slip a hose clamp onto the ends of the hose. With a twisting motion, slip the hose all the way onto the fitting and secure with the hose clamp.

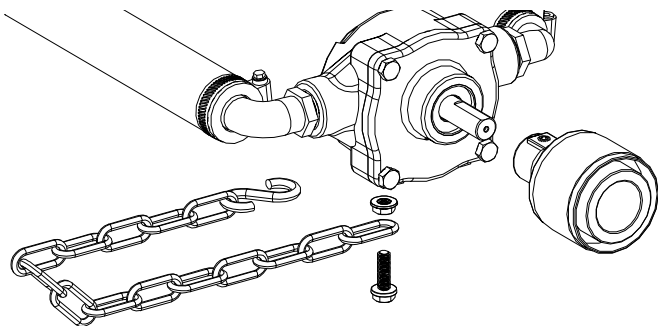

5. The roller pump IS included with the assembly. Attach the adapter, the torque chain and S-hook to the pump as needed. It is intended for your pump to be mounted directly to the tractor PTO. The torque chain needs to be secured to the tractor to keep your pump from spinning.

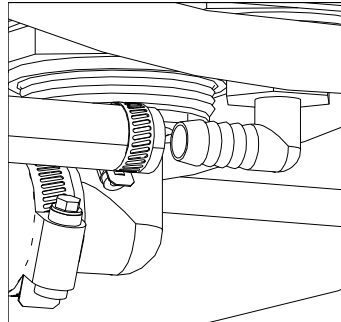

2. Slide a hose clamp on to the 1/2" bypass hose (from the relief valve), then with a twisting motion, slip the bypass hose over the fitting on the bottom of the tank. Slide the hose clamp to the end of the hose and secure.

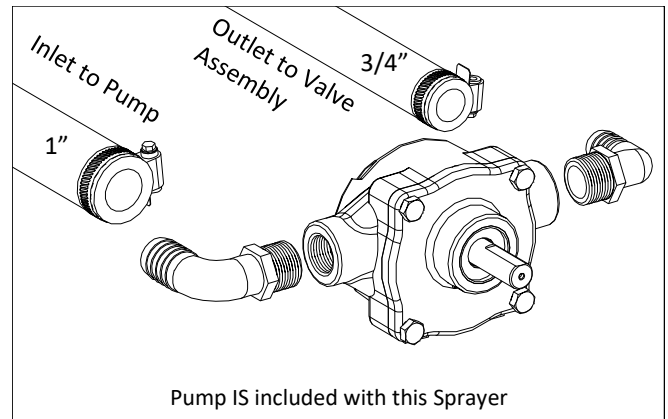

4. Using a good quality thread sealant, thread the 1" fitting into the inlet (IN) side of the pump and the 3/4" fitting to the outlet (OUT) side of the pump. With a twisting motion, attach the other end of the 1" hose to the 1" fitting on the inlet to the pump. Slip a 3/4" hose clamp onto the 3/4" hose coming off the valve assembly and with a twisting motion, attach the 3/4" hose to the output side of the pump and securing with the hose clamp.

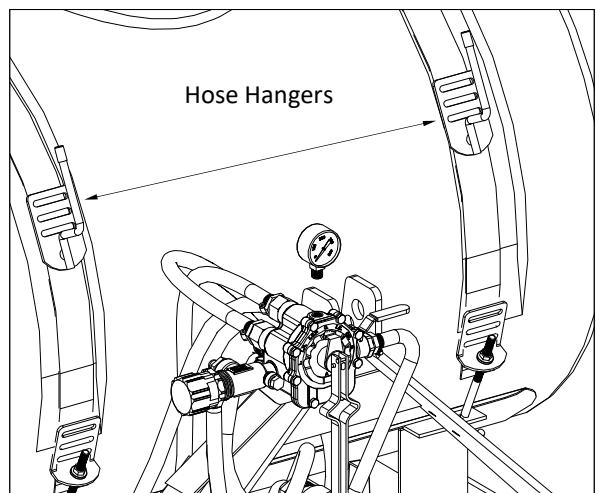

6. Wrap the handgun hose around the hose hangers which are attached to the tank straps.
7. Using sealant thread the gauge into the top of the tee valve assembly.

Boom Assembly Procedure

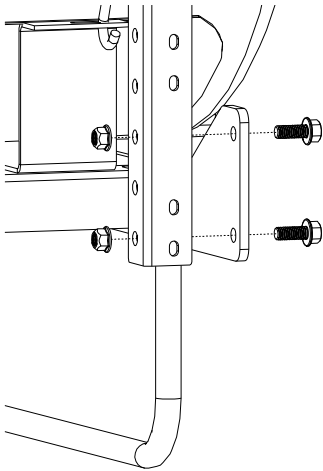

8. Mount the upright angles to the inside of the mounts on the 3-point carrier using the supplied 1/2" bolts and nuts.
9. Attach the backrack to the upright angles using the square U-bolts and nuts. Note: the backrack can be mounted in either a high or low position and the uprights can be adjusted for desired height.
10. Attach the U-brackets as shown.

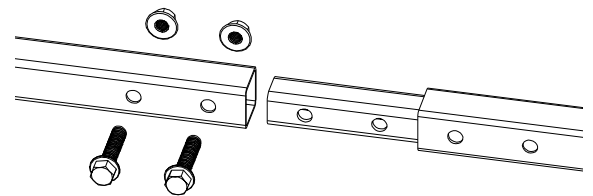
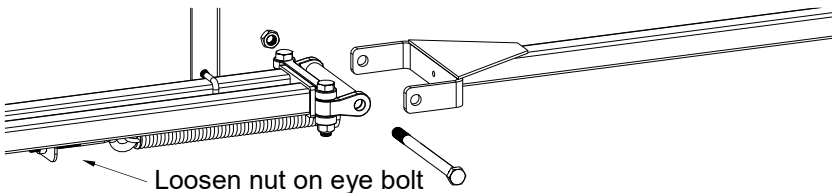
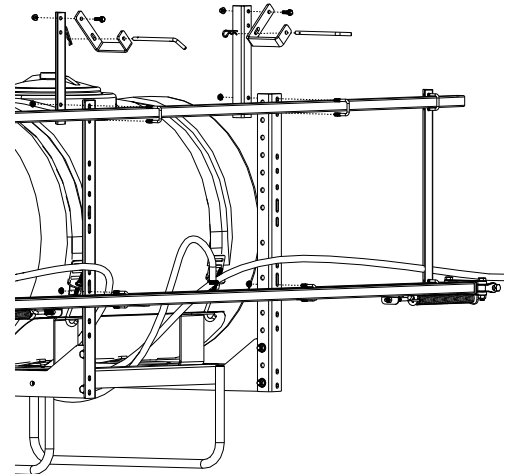

11. Loosen the eye bolts and remove the 7" hinge bolts. Line up the outer booms and reassemble the hinge bolt through the outer boom yoke, the hinge casting and the spring connector. Tighten the eye bolt until the spring is at the desired tension. Lock the eye bolt in place with the inner whiz flange locknut.
12. Bolt on the boom extensions using the 3/8" x 1-3/4" bolts and hex lock nuts.

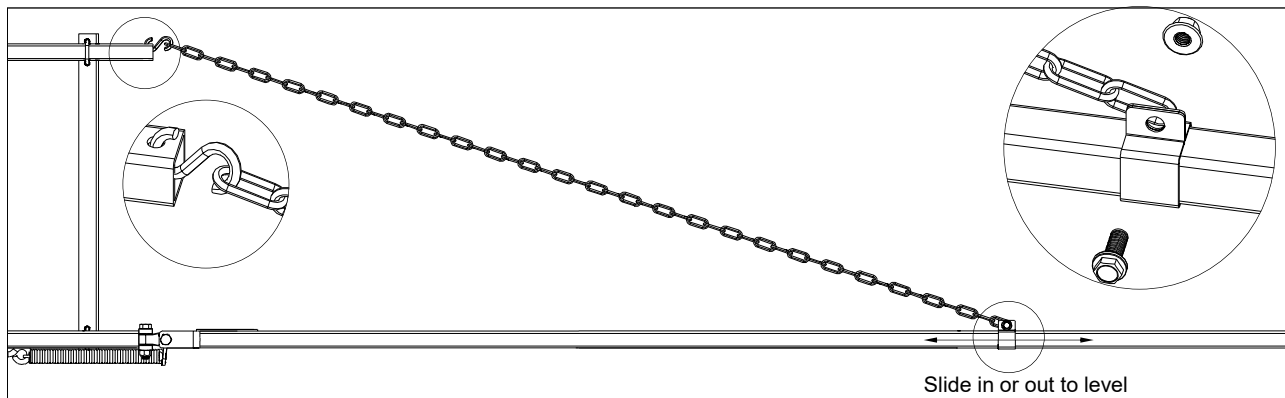

13. Hook an end of each boom chain on an "S" hook attached to the top bar tube.
14. Slip a slide clamp onto each outer boom. Place the other end of the boom chain between the ears of the slide clamp and secure with a 3/8" x 1" flange screw. Level the outer booms by moving the slide clamps in or out as needed. Tighten the bolts in the slide clamps to hold the clamps in place.

Assembly Procedure

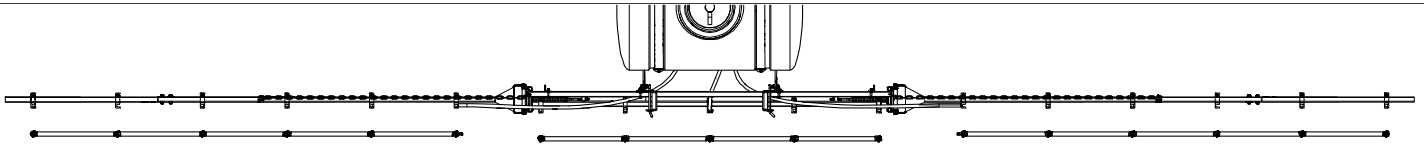

15. Starting with the center section, attach the appropriate hose assemblies onto each of the three boom sections. Center the center hose assembly on the boom, working outward to the ends of the booms. The center section has five nozzles with a cross nozzle assembly to connect your feeder hose to. The end nozzle harness assemblies have a tee nozzle assembly to connect your feeder hose to and should be approx. 20" from the end of your center nozzle harness assembly.

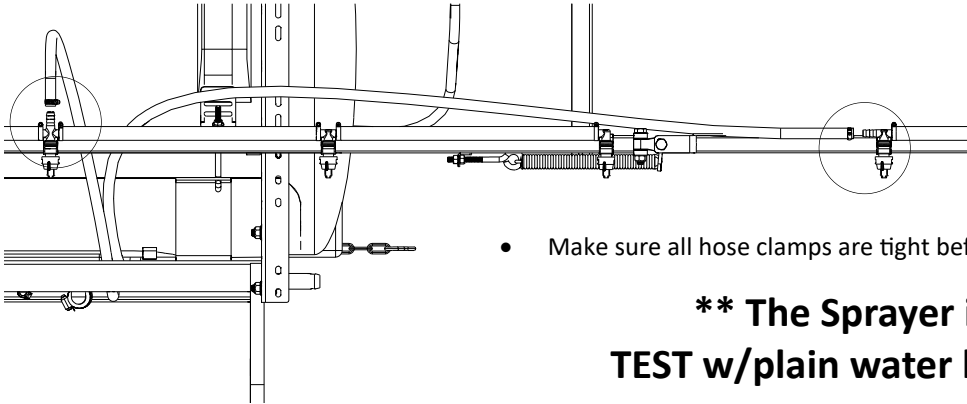

16. Join the designated feeder hose from the tee valve sub-assembly to each boom section and secure in place with hose clamps.

- Make sure all hose clamps are tight before testing or spraying for the first time.

**** The Sprayer is now ready to
TEST w/plain water before actual use ****

Operation Instructions

Information About the Sprayer

Roller pumps are positive displacement pumps, which means that the entire solution being pumped must go somewhere or the pump will break. In this roller pumping system, solution is drawn from the tank and forced to a planned source, such as boom nozzles or handgun. The pressure is controlled by a pressure relief valve, which is a spring-loaded device that controls the amount of fluid bypassed (recirculated) to the tank. The gray handle is to be tightened to increase pressure and loosened to decrease pressure. The 'directo-valve' is the on/off control which allows the operator to manually control the solution going to the boom.

IMPORTANT: Remove tank lid and be sure the tank is clean and free of any foreign material. Rinse tank out of any tank residue before filling with water to test.

Testing the Sprayer

Attach the sprayer to the tractor 3 point hitch. Mount the pump to the PTO and affix the torque chain.

NOTE: It is important to test the sprayer with plain water before actual spraying is attempted. This will enable you to familiarize yourself and check for leaks without the possibility of losing any expensive chemicals.

Fill the tank about 1/2 full with plain water. Before starting, open the suction line valve (located underneath the carrier frame), turn the relief valve handle out to lower the line pressure. This will help prime the pump.

CAUTION: Always be sure that the water (or solution) has reached the pump before starting your sprayer. If the pump is allowed to run dry, serious damage to the pump will result.

Always have the pressure line open to the tips so that the air which may be trapped in the line will be forced (or purged) out. Start the tractor PTO. Check the entire system for leaks. Once the pump is primed, the pressure may be increased by turning the handle of the pressure relief valve in. Keep the pressure line open to the tips when setting the pressure. Set the pressure and then lock the relief valve handle in place. Shut off the directo-valve and check for leaks again. Pressure will increase when the pressure line valve is closed and then return to the preset pressure when the valve is opened again.

During the testing period, be sure to observe the spray pattern given by the spray nozzles. If there is any pattern distortion, it will be necessary to remove and clean the affected tips.

Caution: Never use a metal object or other sharp item for cleaning a nozzle tip. It is better to use a nozzle brush (NOT wire brush) or compressed air for tip cleaning.

Conditions of weather and terrain must be considered when setting the sprayer. Do not spray on windy days. Protective clothing must be worn in some cases

Be sure to read the chemical label(s) before application!

Operation

The performance of any agricultural chemical depends upon the proper application.

Always fill the tank with a desired amount of water first and then add the chemical slowly, mixing as you pour the chemical into the tank. You may use the handgun to spraying into the solution in order to mix the chemical and water.

Only fill the tank with what you're going to spray in a day, never leave chemicals sit in tank.

The tips supplied as standard with the sprayer can be used for a wide variety of spraying applications. Other tip sizes are available for different coverages. The speed and pressure charts shown indicate the rates can be changed considerably by changing speed and pressure. The pumping system draws solution from the tank through the strainer/filter and to the pump. The pump forces the solution under pressure to the boom nozzles.

Tip Information

Important note about tips: When you refer to the rate charts found in this owners manual, these rates are based on water. Please read this tip selection section carefully before attempting to operate your boom assembly.

The selection of proper tips for the boom is determined by the gallon per acre (GPA) requirement which is specified on the chemical label. The following characteristics also have a determining factor and must be considered.

1. Speed of spraying (MPH).
2. Boom nozzle spacing (specified in inches).
3. Solution weight and conversion factor (CF)
4. Gallons of solution to be sprayed per acre.
5. Spraying pressure.

Suggested Minimum Spray Heights				
Nozzle Type	Nozzle Height			
	Spray Angle	20" Spacing	30" Spacing	40" Spacing
TeeJet (Flat Spray)	65°	22"-24"	33"-35"	NR*
TeeJet (XR TeeJet)	80°	17"-19"	26"-28"	NR*
TeeJet (XR TeeJet)	110°	12"-14"	16"-18"	NR*
FloodJet	120°	***	***	***

* Not Recommended

*** Wide Angle Spray Tip is influenced by nozzle orientation.

The critical factor is to achieve a double spray patten overlap.

Useful Formulas:

GPM = Gallons Per Minute

GPA = Gallons Per Acre

MPH = Miles Per Hour

Calibration

Chemical labels may show application rates in gallons per acre, gallons per 1000 square feet or gallons per 100 square feet. You will note that the tip chart (later in this manual) shows 2 of these rating systems. Once you know how much you are going to spray, then determine (from the tip chart) the spraying pressure (PSI), and the spraying speed (MPH).

Determining the proper speed of the pulling vehicle can be done by marking off 100, 200 & 300 feet. The speed chart indicates the number of seconds it takes to travel the distances. Set the throttle and with a running start, travel the distances. Adjust the throttle until you travel the distances in the number of seconds indicated by the speed chart. Once you have reached the throttle setting needed, mark the throttle location so you can stop and go again, returning to the same speed.

Add water and proper amount of chemical to the tank and drive to the starting place for spraying

Speed Chart			
Speed in M.P.H. (Miles Per Hour)	Time Required in seconds to travel a distance of		
	100 Ft.	200 Ft.	300 Ft.
1.0	68 sec.	136	205
2.0	34	68	102
3.0	23	45	68
4.0	17	34	51
5.0	14	27	41
6.0	11	23	34
7.0	9.7	19	29
8.0	8.5	17	26
9.0	7.6	15	23
10.0	6.8	14	20

AIXR11003VP Spray Tip Rate Chart (20" Spacing)									
	Pressure (psi)	Capacity (GPM)	1 MPH	2 MPH	3 MPH	4 MPH	5 MPH	6 MPH	8 MPH
Gallons Per Acre Based on Water	15	.18	53.6	26.8	17.8	13.4	10.7	8.9	6.7
	20	.21	62.4	31.2	20.8	15.6	12.5	10.4	7.8
	30	.26	77.2	38.6	25.8	19.3	15.4	12.9	9.7
	40	.30	88.0	44.0	29.8	22.0	17.8	14.9	11.1
Gallons Per 1000 Sq. Ft. Based on Water	15	.18		.61	.41	.31	.24		
	20	.21		.71	.48	.36	.29		
	30	.26		.88	.59	.44	.35		
	40	.30		1.0	.68	.51	.41		

Using the Boom Nozzles

Four things must be considered before spraying with the boom.

1. How much chemical must be mixed in the tank.
 2. Rate of spray (gallons per acre to be sprayed).
 3. What pressure (p.s.i.) will be used.
 4. Speed traveled (mph) while spraying.
- * Refer to the chemical label to determine your chemical mixture
 - * See the tip chart to determine the pressure to be used. The chart will also show the speed used when spraying.
 - * Start the pump and open the valve to the boom nozzles.
 - * Check the spray pattern. Usually you can see the coverage better on a solid concrete surface, such as a driveway.

Spraying Solutions Other Than Water

Since all the tabulations are based on spraying water, which weighs 8.34 lbs. per USA gallon, conversion factors must be used when spraying solutions which are heavier or lighter than water. To determine the proper size nozzle for the solution to be sprayed, first multiply the desired GPM or GPA of solution by the rate conversion factor. Then use the new converted GPM or GPA rate to select the proper size nozzle.

Example: Desired application rate is 20 GPA of 28% Nitrogen.

Determine the correct nozzle size as follows:

GPA (Solution) x Conversion Factor = GPA

20 GPA (28%) x 1.13 = 22.6 GPA (Water)

The applicator should choose a nozzle size that will supply 22.6 GPA of water at the desired pressure.

Weight of Solution	Specific Gravity	Conversion Factors
7.0 lbs. per gallon	.84	.92
8.0 lbs. per gallon	.96	.98
8.345 lbs. per gallon (Water)	1.00	1.00
9.0 lbs. per gallon	1.08	1.04
10.0 lbs. per gallon	1.20	1.10
10.66 lbs. per gallon (28% Nitrogen)	1.28	1.13
11.0 lbs. per gallon	1.32	1.15
12.0 lbs. per gallon	1.44	1.20
14.0 lbs. per gallon	1.68	1.30

Miscellaneous Conversion Factors

One Acre = 43,560 square feet = 0.405 Hectare

One Hectare = 2.471 Acres

One Gallon Per Acre = 9.35 Liters Per Hectare

One Mile = 5,280 Feet = 1,610 Meters = 1.61 Kilometers

One Gallon = 128 Fluid Ounces = 8 Pints = 4 Quarts = 3.79 Liters = 0.83 Imperial Gallons

One Pound Per Square Inch = 0.069 bar. = 6.895 Kilopascals

One Mile Per Hour = 1.609 Kilometers Per Hour

Higher pressure not only increases the flow rate of the nozzle, but it also influences the droplet size and the rate of orifice wear. As pressure is increased, the droplet size decreases and the rate of orifice wear is increased. The values given in the tabulation section of this owners manual indicate the most commonly used pressure ranges for the associated spray tips.

Tank Care & Maintenance

Warning: Do not use the tank as a container for fuel oils, kerosene, gasoline or any other petroleum distillate product. All polyolefins are softened and permeated by such products. In an enclosed area the vaporization of these materials from the outside surface of the tank could create a dangerous condition.

The tank should not be used as a pressure vessel nor used with chemicals or solutions having a weight of more than 12 pounds per gallon.

Store the tank in a dry dark place when not in use. Storage out of sunlight will prolong the life of the tank.

Do not drop, strike or kick the tank, especially at low temperatures. Tanks become brittle and are subject to cracking at temperatures below 20° Fahrenheit.

Maintenance During/After Spraying

Periodically close the suction line valve and check the strainer and clean the screen.

Proper care and maintenance will prolong the life of your sprayer.

After use, fill the sprayer tank part way with water. Start the sprayer and allow the clear water to be pumped through the plumbing system and out through the spray nozzles. Refill the tank about half full with plain water and use FIMCO Tank Neutralizer and Cleaner and repeat cleaning instructions above (If no tank cleaner is available, you may substitute dish soap for this step, about 1-2 oz. per gallon). A neutralizer/cleaner should be used to thoroughly clean the system.

Flush the entire sprayer with the neutralizing/cleaning agent, then flush out one more time with plain water.

Follow the chemical manufacturer's disposal instructions of all wash or rinsing water. For the boom (if applicable) remove the tips and screens from the nozzle assemblies. Wash these items out thoroughly. Blow the orifice clean and dry. If the orifice remains clogged, clean it with a fine bristle (NOT WIRE) brush or with a toothpick. Do not damage the orifice. Water rinse and dry the tips before storing.

WARNING: Some chemicals will damage the pump valves if allowed to soak untreated for a length of time! ALWAYS flush the pump as instructed after each use. DO NOT allow chemicals to sit in the pump for extended times of idleness. Follow the chemical manufacturer's instructions on disposal of all waste water from the sprayer.

Winter Storage

Drain all water out of your sprayer, paying special attention to the pump, handgun and valve(s). These items are especially prone to damage from chemicals and freezing weather.

The sprayer should be winterized before storage by pumping a solution of automotive antifreeze (containing a rust inhibitor) through the entire plumbing system. This antifreeze solution should remain in the plumbing system during the winter months.

When spring time comes and you are preparing your sprayer for the spray season, rinse the entire plumbing system out, clearing the lines of the antifreeze solution. Proper care and maintenance will prolong the life of your sprayer.

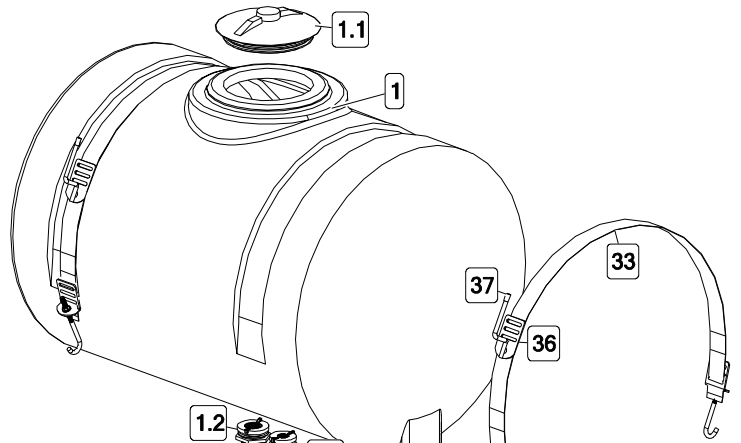
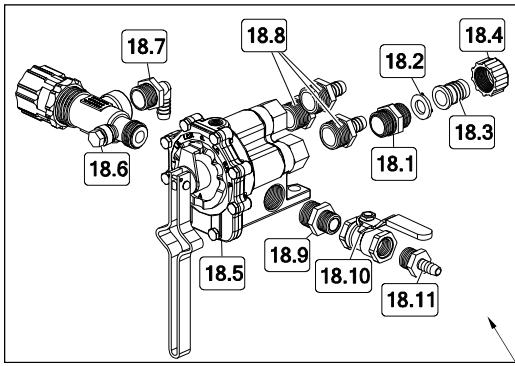

**Exploded View:
110-3PT-17N
(5303082)**

Refer to the parts list
next page for part numbers.

Refer to
pages 9-11
For Boom
breakdown &
Part
Numbers

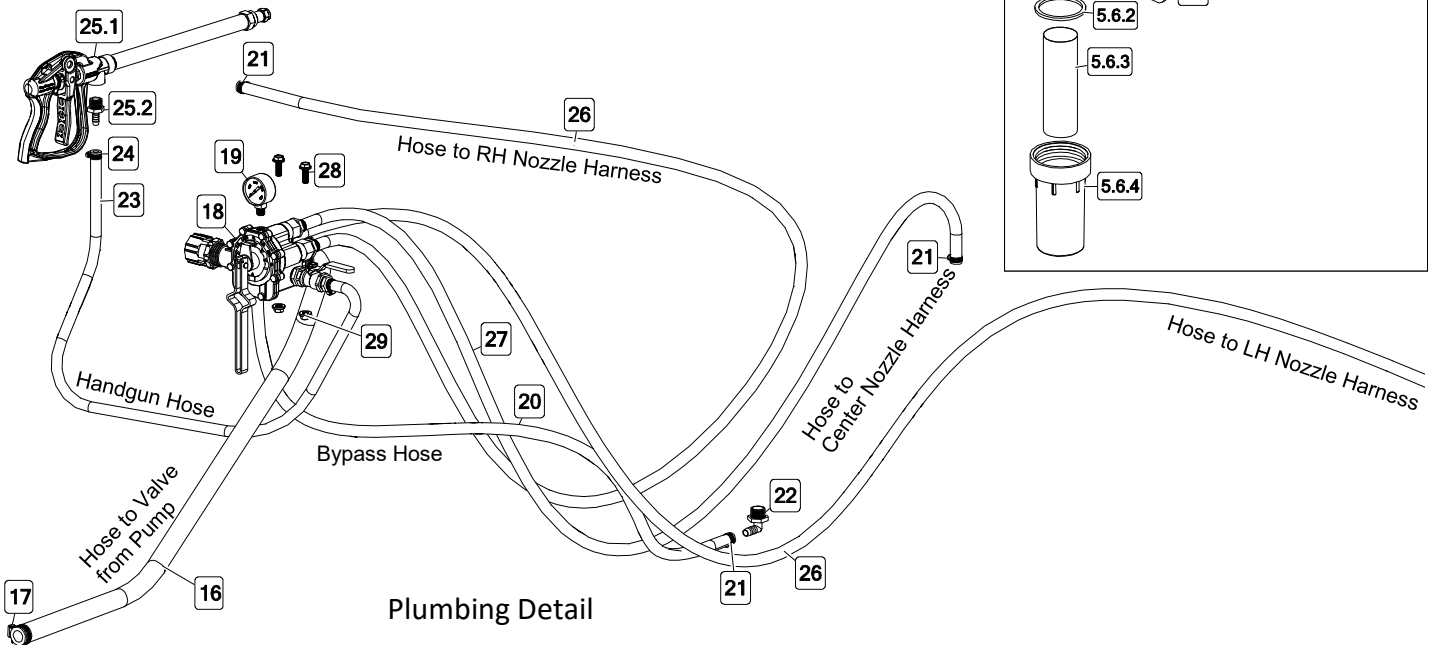
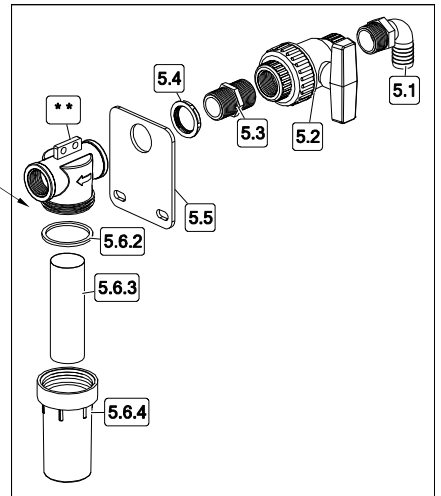
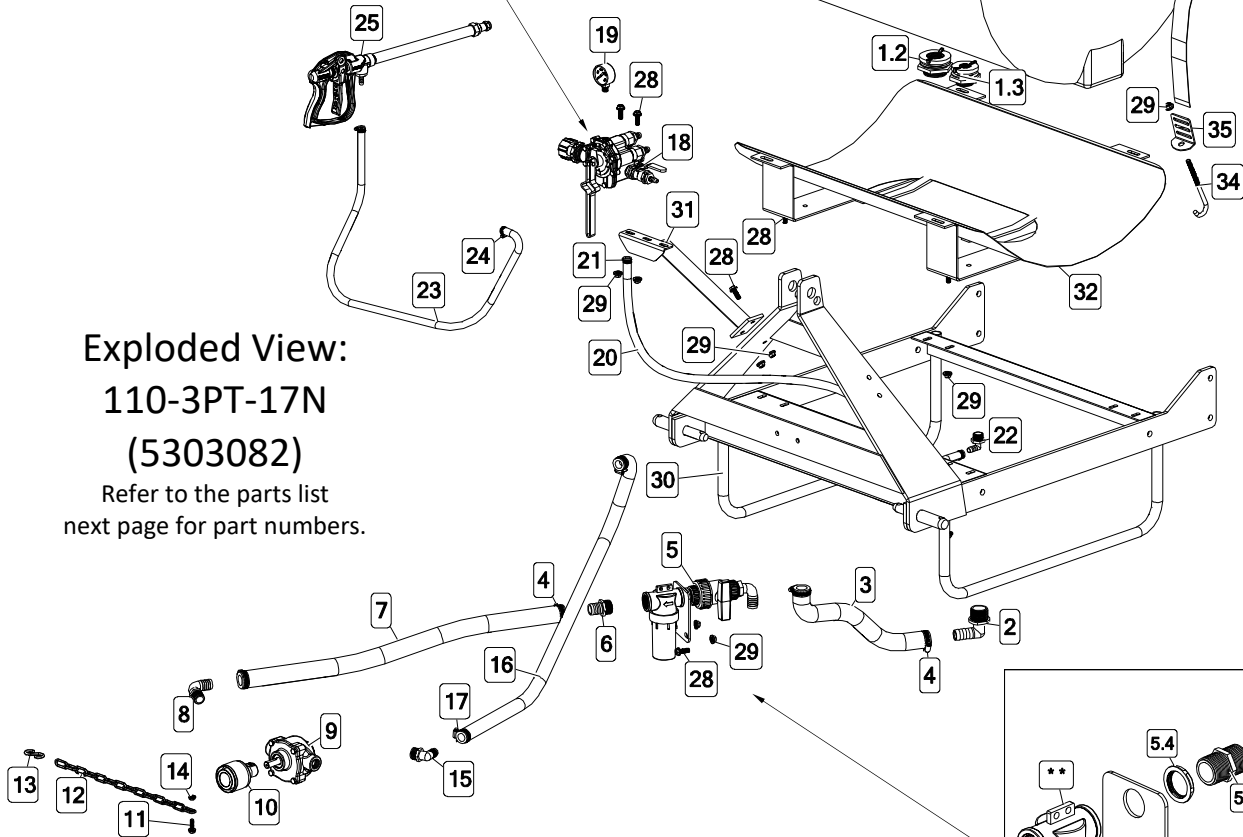

Plumbing Detail

Parts List: 110-3PT-17N (5303082)

Ref. #	Part #	Description	Qty
1	5169003	110 Gallon Tank (30" Dia.)	1
1.1	63480	8" Lid w/Blue Snap-In Vent	1
1.2	5274362	1-1/4" Double-Threaded Bulkhead Fitting	1
1.3	5273736	3/4" Double-Threaded Bulkhead Fitting	1
2	5010215	Poly Elbow, 1 1/4" MNPT x 1" HB	1
3	5020315	Hose, 1"-2 Brd. x 24"	1
4	5051025	Hose Clamp (1")	4
5	5274765	Strainer Sub-Assembly	1
5.1	5010213	Poly Elbow, 1" MNPT x 1" HB	1
5.2	5143207	1" Single Union Ball Valve	1
5.3	5011141	Poly Close Nipple, 1" MNPT	1
5.4	5006394	1" NPT Nylon Lock Nut	1
5.5	5038247-BLK	Strainer Bracket	1
5.6	5116441	1" Nylon Strainer (Black, 40 Mesh)	1
5.6.1	**	Strainer Cap (Avail. ONLY in Comp. Assy)	1
5.6.2	5072229	EPDM Gasket	1
5.6.3	5116180	Screen (40 Mesh)	1
5.6.4	5058075	Strainer Bowl	1
6	5067118	Poly Fitting, 1" MNPT x 1" HB	1
7	5020338	Hose, 1"-2 Brd. x 36"	1
8	5010210	Poly Elbow, 3/4" MNPT x 1" HB	1
9	5271706	6-Roller Pump Assembly (6500C)	1
10	5057145	Quick Coupler (5/8")	1
11	5117300	5/16-18 x 1" Fling Hex Bolt	1
12	5049017	Torque Chain, 24"	1
13	5082006	"S" Hook	1
14	5006307	5/16"-18 Serrated Fling Hex Nut	1
15	5010209	Poly Elbow, 3/4" MNPT x 3/4" HB	1
16	5020179	Hose, 3/4"-2 Brd. x 6 Ft. (72")	1
17	5051024	Hose Clamp (3/4")	2
18	5275731	TeeValve Plumbing Assembly	1
18.1	5005196	Poly Adapter, 3/4" MNPT x 3/4" MGHT	1
18.2	5016066	1" Rubber Washer	1

Ref. #	Part #	Description	Qty
18.3	5149037	Poly Swivel, 3/4" Flat Seat Hose Barb	1
18.4	5006209	Poly Knurled Swivel Nut, 3/4" FGHT	1
18.5	5143295	TeeValve Assembly (AA-17L)	1
18.6	5143199	Pressure Relief Valve, 3/4"	1
18.7	5010207	Poly Elbow, 3/4" MNPT x 1/2" HB	1
18.8	5067125	Poly Fitting, 3/4" MNPT x 1/2" HB	3
18.9	5011147	Reducing Nipple, 3/4" MNPT x 1/2" MNPT	1
18.10	5143197	1/2" T-800 Brass Ball Valve	1
18.11	5067130	Poly Fitting, 1/2" MNPT x 3/8" HB	1
19	5167005	Gauge, 0-400 p.s.i. (Dry)	1
20	5020570	Hose, 1/2"-1 Brd. x 48"	1
21	5051114	Hose Clamp (1/2")	8
22	5010207	Poly Elbow, 3/4" MNPT x 1/2" HB	1
23	5020099	Hose, 3/8"-2 Brd. x 25 Ft.	1
24	5051144	Hose Clamp (3/8")	2
25	5163150	22" HP Spray Gun with 3/8" Hose Barb	1
25.1	5163136	High Pressure Aluminum Spray Gun 22"	1
25.2	5067130	Poly Fitting, 1/2" MNPT x 3/8" HB	1
26	5020571	Hose, 1/2"-1 Brd. x 11'	2
27	5020167	Hose, 1/2"-1 Brd. x 90"	1
28	5117307	3/8-16 x 1" Fling Hex Bolt	10
29	5006259	3/8"-16 Serrated Fling Hex Nut	14
30	5271770-RED	3-Point Mounting Weldment (27-D)	1
31	5271771-BLK	Valve Mount	1
32	5273904-BLK	Saddle Weldment (30"-110 Gallon)	1
33	5133101	Nylon Strap (2" x 72")	2
34	5034173	3/8-16 x 3.75 Hook Bolt	4
35	5108041-BLK	Tank Strap Buckle, Bent	4
36	5271863-BLK	Hose Hanger Weldment	2
37	5046085	Cap	2
38	5300658	8-Row Boom Assembly (257-8)	1

** : Available ONLY in complete assembly

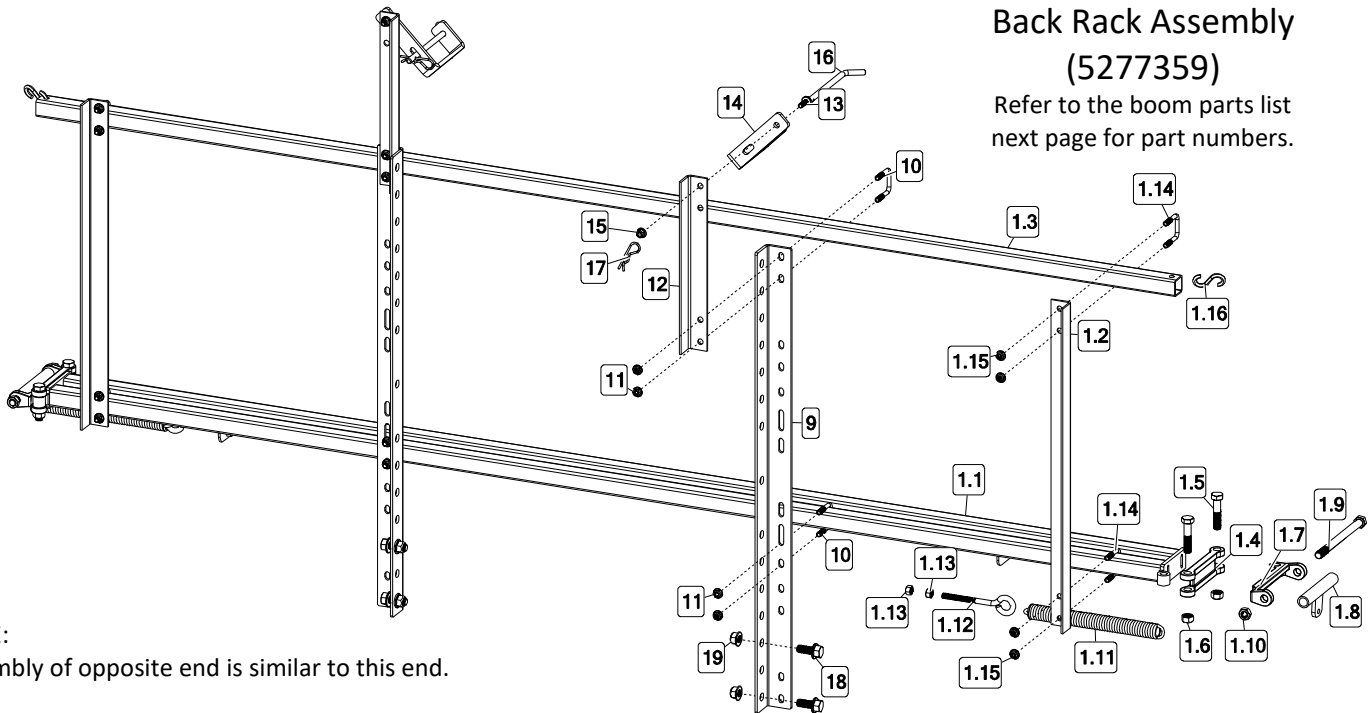

Back Rack Assembly (5277359)

Refer to the boom parts list
next page for part numbers.

NOTE:

Assembly of opposite end is similar to this end.

Bolt (Ref. #1.9) goes through the yoke on the outer boom(s), then through Ref. # 1.7 and 1.8, followed with jam locknut (Ref. # 1.10).

For the eyebolt, thread the first nut (Ref. # 1.13) onto the eyebolt, then feed it through the hole in the angle under the lower center section. Use the next nut for adjusting and the first nut for locking the eyebolt into position.

Model: 257-8 (8-Row) Boom
 Assembly (5300658)

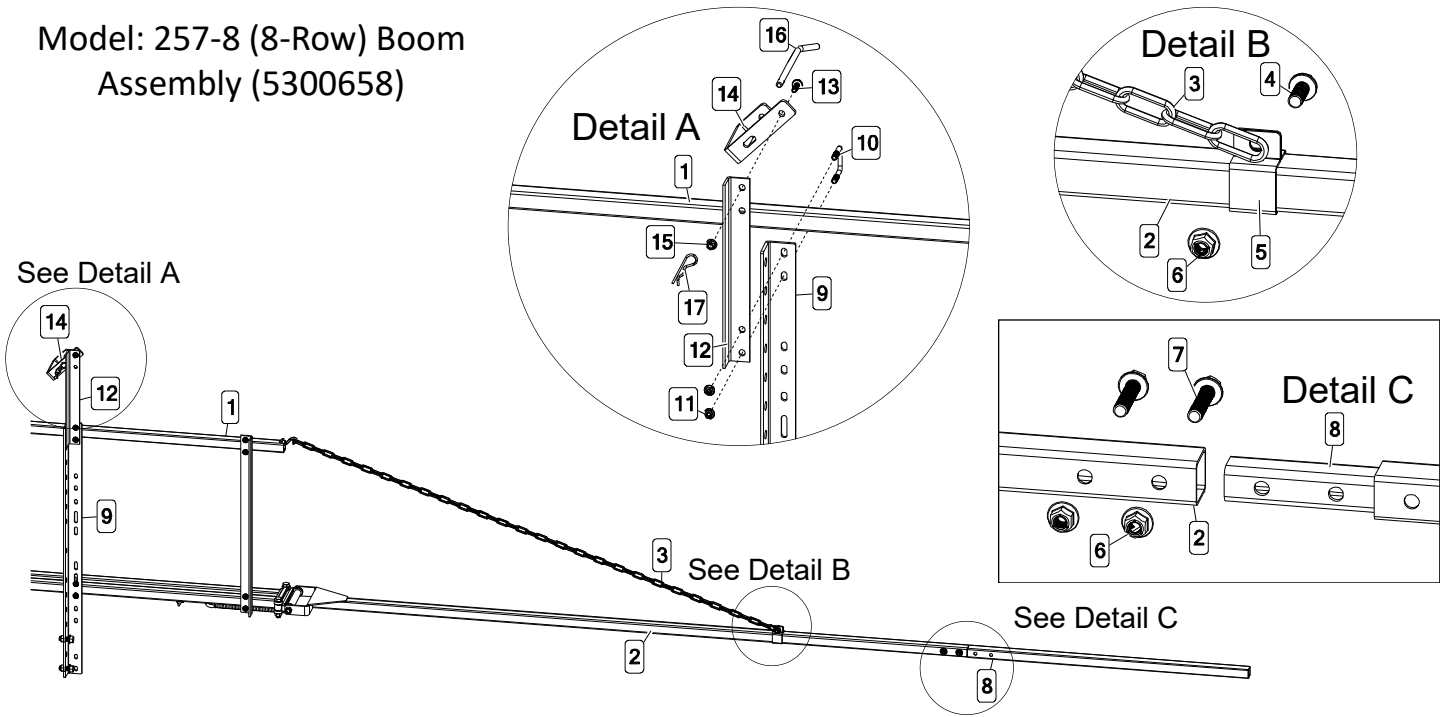

Ref. #	Part #	Description	Qty
1	5277359	257 Boom Center Section Assembly	1
1. 1	5281559-BLK	Center Boom Weldment	1
1. 2	5022256-BLK	End Angle (257 Boom)	2
1. 3	5009635-BLK	Top Bar Tube (257 Boom)	1
1. 4	5080012-BLK	Inner Hinge Section	2
1. 5	5034308	H.H.C.S., 1/2"-13 x 2 1/4"	4
1. 6	5006091	1/2"-13 Top-Lock Hex Nut	4
1. 7	5080011-BLK	Outer Hinge Section	2
1. 8	5271580-BLK	Spring Connector Weldment	2
1. 9	5034074	H.H.C.S., 1/2"-13 x 7"	2
1.10	5006142	Hex Jam Locknut, 5/16"	2
1.11	5019097	Hinge Spring	2
1.12	5034107	3/8"-16 x 4" Eye Bolt	2
1.13	5006054	3/8"-16 Hex Nut	4
1.14	5034159	5/16"-18 x 1.3125 x 1.875 Square U-Bolt	4
1.15	5006307	5/16"-18 Serrated Flng Hex Nut	8
1.16	5082006	"S" Hook	2
2	5273313-BLK	End Boom Weldment	2
3	5049018	Boom Chain (7 Ft.)	2
4	5117307	3/8-16 x 1" Flng Hex Bolt	2

Ref. #	Part #	Description	Qty
5	5051085-BLK	Slide Clamp	2
6	5006345	3/8"-16 Flng Top-Lock Hex Nut	6
7	5034664	3/8"-16 x 1.75" Flng Hex Bolt (Full Thread)	4
8	5275736-BLK	Boom Extension Weldment (8-Row)	2
9	5022255-BLK	Boom Upright Angle	2
10	5034159	5/16"-18 x 1.3125 x 1.875 Square U-Bolt	4
11	5006307	5/16"-18 Serrated Flng Hex Nut	8
12	5022238-BLK	Mounting Angle	2
13	5117300	5/16-18 x 1" Flng Hex Bolt	2
14	5038317-BLK	U-Bracket	2
15	5006389	5/16"-18 Flng Top-Lock Hex Nut	2
16	5101231	Bent Hitch Pin, 3/8" x 7 3/4"	2
17	5101065	Hair Pin, #211 x 2.50	2
18	5034691	1/2"-13 x 1 1/4" Flng Hex Bolt	4
19	5006365	1/2"-13 Flng Top-Lock Hex Nut	4
20	5277894	257-8 Nozzle Harness	1
20.1	5277761	257 Center Nozzle Harness	1
20.2	5277806	Wing Nozzle Harness (257-8)	2
20.3	5272165	Vari-Quick Clamp (1 1/4" Sq. Tube)	17

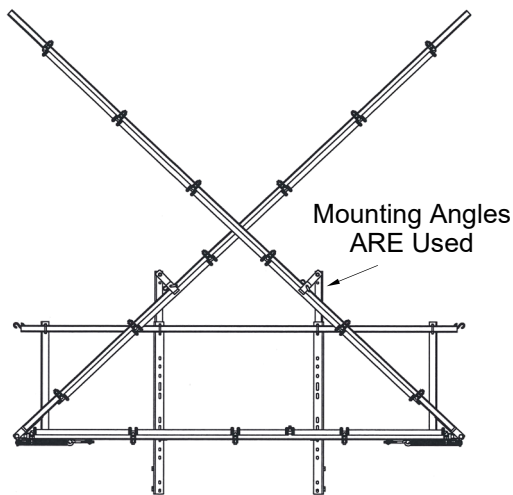

Center "Back-Rack" Mounted
 In "High" Position

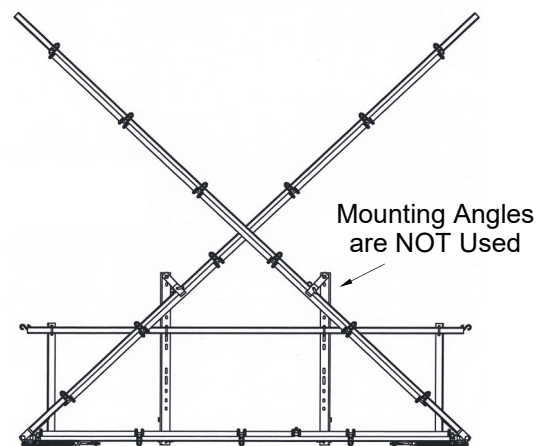

Center "Back-Rack" Mounted
 In "Low" Position

257-8 (STD) Harness Parts List

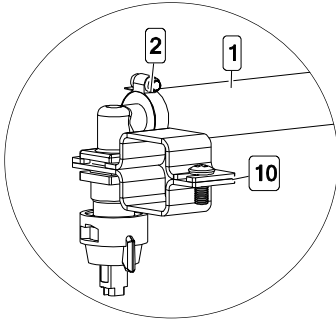
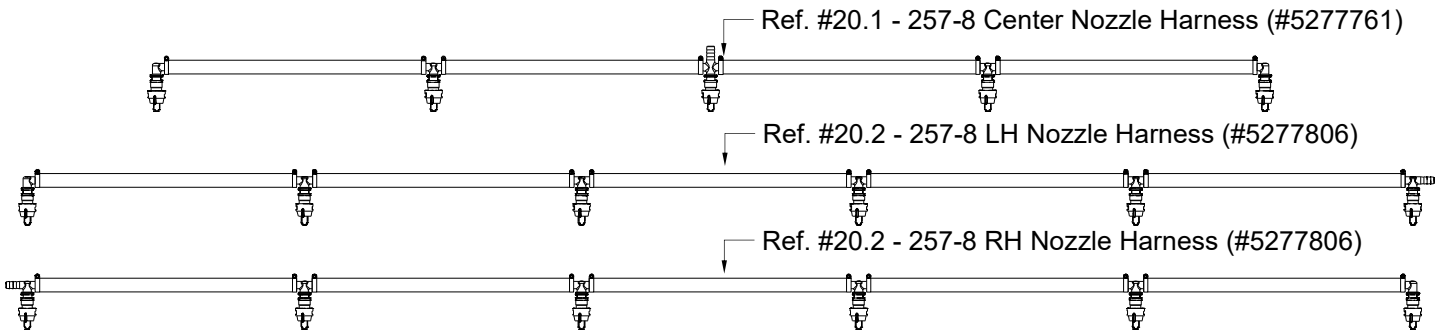

NOTES:

All hoses in this boom assembly are part #5020569 (Ref. # 1)

All hose clamps (2 per hose) are #5051114 (Ref. # 10)

Ref. #	Part #	Description	Qty
1	5020569	Hose, 1/2"-1 Brd. x 19 3/8"	14
2	5051114	Hose Clamp (3/8"-1/2")	28
3	5056065	Single Hose Shank (1/2")	4
4	5056067	Double Hose Shank (1/2")	12
5	5056069	Triple Hose Shank (1/2")	1
6	5143543	Nozzle Check Strainer, Blue (50 Mesh)	17
7	5016157	Seat Washer - EPDM - QJ Caps	17
8	AIXR11003VP	Air-Induction XR Flat Spray Tip	17
9	5046217	Quick Cap - Blue	17
10	5272165	Vari-Quick Clamp (1 1/4" Sq. Tube)	17

The AIXR TeeJet Flat Spray Tip offers the benefits of obtaining excellent drift resistance without compromising spray coverage. Tips producing very coarse droplets do minimize drift but do not provide the same surface coverage as tips that produce smaller droplets. In some applications, inadequate coverage decreases the effectiveness of the applied chemicals.

AIXR Features and Benefits

- 110° wide, tapered flat spray angle with air induction technology for better drift management.
- Made of 2-piece UHMWPE polymer construction which provides excellent chemical resistance, including acids, as well as exceptional wear life.
- Compact size to prevent tip damage.
- Removable pre-orifice.
- Excellent for systemic products and drift management.

Typical Nozzle Assembly Configurations

Elbow Assembly #5281310	Tee Assembly #5281312	Cross Assembly #5281314
-------------------------------	-----------------------------	-------------------------------

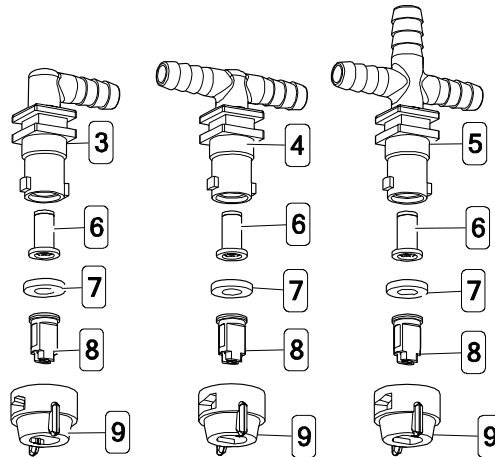

Nozzle Assemblies consist of "Elbow", "Tee" & "Cross" style nozzles.

Assemblies include: Nozzle Body, Strainer, Seat Washer, AIXR11003VP Nozzles & Nozzle Cap

PRO SERIES Long Range Ergonomic Handguns

Technical Specifications:

- Adjustable Spray Pattern
- No Drip Shut Off
- Aluminum Barrel
- Convenient Hanger Hole
- 600 PSI, 8 GPM
- Chemical Resistant Construction
- 38' Horizontal, 27' Vertical Maximum Spray Distance
- Adjustable On/Off Trigger Stop for Precise Spray Pattern

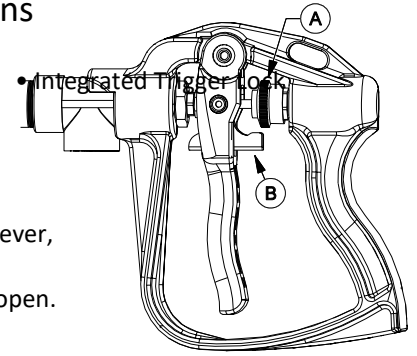

To adjust the spray pattern, the nut needs to be adjusted (Ref. A). Spinning it off, towards the lever, will make a cone pattern and spinning it on, away from the lever, will make a stream. The lever (Ref. B), is the lock that can be used to lock the lever when pulled, holding the valve open. Squeezing the trigger, will release the lock.

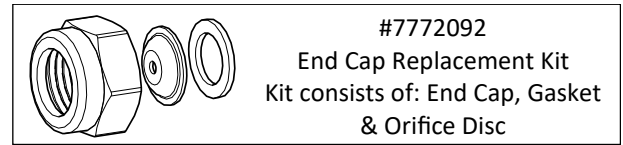
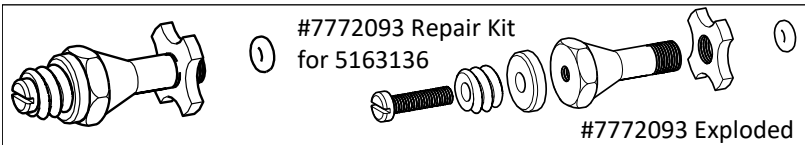

Torque Chain Attachment to a Roller Pump

Torque chain, 'S' hook, nut and bolt are included to secure your pump during operation.

1. Attach end of the torque chain over stem of bolt
2. Thread the whiz nut onto the bolt. Hand-tighten.
3. Thread 'pre-assembly' into the threaded hole on the underside of the pump. Tighten sufficiently
4. Affix the 'S' Hook and wrap the chain around the frame or hitch and 'S-Hook' it in place. Make sure connection is very secure! If not secured, it may result in the pump spinning on PTO shaft and damaging some components of your sprayer.

*** Insure that this connection point will not allow the roller pump to spin on the PTO shaft ***

Strap/Buckle Detail

Strap Attachment to a "Bent" Buckle

Approx. 6"

The nylon straps are to be inserted in and out of the slots in the buckle, as shown. Be sure straps are snug before tightening the hook bolts. In most cases, it will be necessary to re-tighten the straps after filling the tank with liquid.

Cast Iron 6-Roller Pump Assembly #5271706 (Hypro Mfg. Part # 6500C)

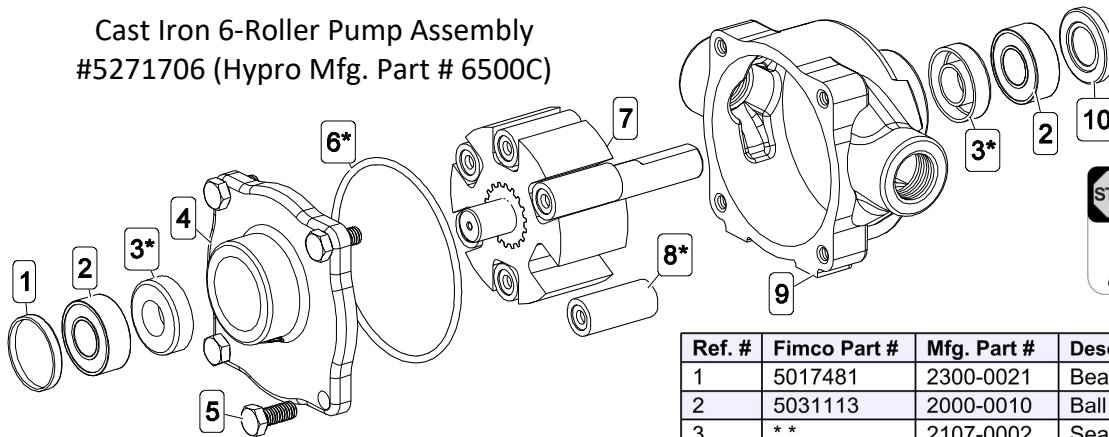

STOP WARNING STOP

DO NOT USE PUMP IN AN EXPLOSIVE ENVIRONMENT. DO NOT USE TO PUMP FLAMMABLE/COMBUSTIBLE FLUIDS, GASOLINE, KEROSENE, FUEL, OIL, ETC.

Ref. #	Fimco Part #	Mfg. Part #	Description	Qty
1	5017481	2300-0021	Bearing Cover	1
2	5031113	2000-0010	Ball Bearing (Sealed)	2
3	**	2107-0002	Seal (Viton)	2
4	◆◆	0200-6600C	Endplate (Cast Iron) w/Seal	1
5	5034038	---	H.H.C.S. 5/16"-18nc x 3/4"	4
6	**	1720-0008	O-Ring Gasket for Endplate	1
7	◆◆	0300-6600C	Rotor/Shaft Assembly	1
8	**	1005-0004	Super Roller (Standard)	6
9	◆◆	0100-6600C	Body (Cast Iron) w/Seal	1
10	5017480	2300-0023	Shaft Bearing Cover	1

** = Available ONLY in Repair Parts Kit #7771795 (3430-0380) Consists of Rollers, O-Ring & Viton Seals

◆◆ Available ONLY in Complete Assembly

Roller Pump General Safety Information

1. Use a pressure relief device on the discharge side of the pump to prevent damage from pressure buildup when the pump discharge is blocked or otherwise closed and the power source is still running.
2. **WARNING:** Never pump flammable or explosive fluids such as gasoline, fuel oil, kerosene, etc. Never use in explosive atmospheres. The pump should be used only with liquids compatible with the pump component materials. Failure to follow this warning can result in personal injury and/or property damage and will void the product warranty.
3. Never pump acids (i.e. acid fertilizer) with Super Rollers!
4. Never run the pump faster than maximum recommended speed.
5. Never pump at pressures higher than the maximum recommended pressure.
6. Never pump liquids at temperatures higher than the recommended maximum temperatures (140°F/60°C).
7. Make certain that the power source conforms to the requirements of your equipment.
8. Provide adequate protection in guarding around the moving parts such as the shaft and pulleys.
9. Disconnect power before servicing.
10. Release all pressure within the system before servicing any component.
11. Drain all liquids from the system before servicing any component.
12. Check all hoses for weak or worn condition before each use. Make certain that all connections are tight and secure.
13. Periodically inspect the pump and the system components. Perform routine maintenance as required.
14. Never operate a gasoline engine in an enclosed area. Be sure the area is well ventilated.
15. Use only pipe, hose and fittings rated for the maximum psi rating of the pump.
16. Never use pump for pumping water or other liquids for human or animal consumption.

Roller Pump Operation & Maintenance

WARNING: Never pump corrosive or abrasive liquids as these will cause rapid wear or deterioration of the body, rotor, shaft and seals in the pump. The pump should be used on with liquids compatible with pump component materials. Never exceed maximum specified rpm and pressure. Never run pump dry. Failure to follow this warning will void the product warranty.

Priming the Pump:

To help prime the pump, keep the inlet or suction line as short as possible with a minimum of bends, elbows and kinks. Make sure all connections are tight and do not leak air. Make sure line strainer is free of debris. If pump does not self-prime, disconnect suction hose, fill with water and reconnect to liquid source. Often a squirt of oil into the ports of the pump will seal clearance and help priming.

Care of the Pump:

Proper care and maintenance will keep your pump wear at a minimum and will keep it running smoothly and trouble-free for a long time.

Flush the Pump After Each Use

One of the common causes of faulty pump performance is “gumming” or corrosion inside the pump. This prevents rollers from moving freely in their rotor slots. Flush the pump with a solution that will neutralize liquid pumped, mix according to manufacturer’s directions.

To Prevent Corrosion:

After cleaning pump as above, flush it with a 50-50 solution of permanent-type automotive antifreeze (containing a rust inhibitor) and water. A rust inhibitor can also be squirted into the ports of the pump. Turn shaft several times to draw protective liquid through pump and coat entire inner surface. Drain pump and plug ports to keep out air during storage. For short periods of idleness, noncorrosive liquids may be left in the pump, but air must be kept out. Plug ports or seal port connections.

Troubleshooting		
Symptom	Probable Cause(s)	Corrective Action
Pump Does Not Prime	Leak in suction line	Check hose and fittings for leaks and correct
	Obstruction in suction line	Inspect hose for debris or loose inner liner in hose
	Suction hose sucked to bottom or side of tank	Cut a notch or "V" in end of suction hose
	Rollers stuck in pump	Disassemble pump and inspect rollers
	Pump seals leaking air	Replace seals
Loss of Pressure	Clogged suction strainer	Check strainer and clean it regularly
	Kinked or blocked suction hose	Inspect suction hose and repair as necessary
	Air leak in inlet side plumbing	Check hose and connections for leaks Use pipe joint sealant and retighten connections
	Relief valve setting too low or weakened spring	Check relief valve and correct setting
	Faulty Gauge	Replace gauge
	Pump seals leak air	Replace seals
	Nozzle orifices worn	Replace nozzles
	Pump worn	Repair pump
Pump will not turn	Corrosion (rust), scale or residue	Loosen endplate bolts. Squirt oil into ports to help free rotor. Retighten bolts.
	Solid object lodged in pump.	Disassemble pump and remove objects

Piston Type Pressure Relief/Regulating Valves

Bypasses excess fluid. Adjustable to maintain control of line pressure at any pressure within the valve operating range.

Selected pressure setting firmly held in place by locknut. Extra large passages to handle large flows.

- Polypropylene with stainless steel spring
- Excellent chemical resistance
- EPDM O-Rings
- Fore pressure to 150 p.s.i.
- 1/4" port for pressure gauge
- 3/4" NPT (M) inlet & (F) outlet connections

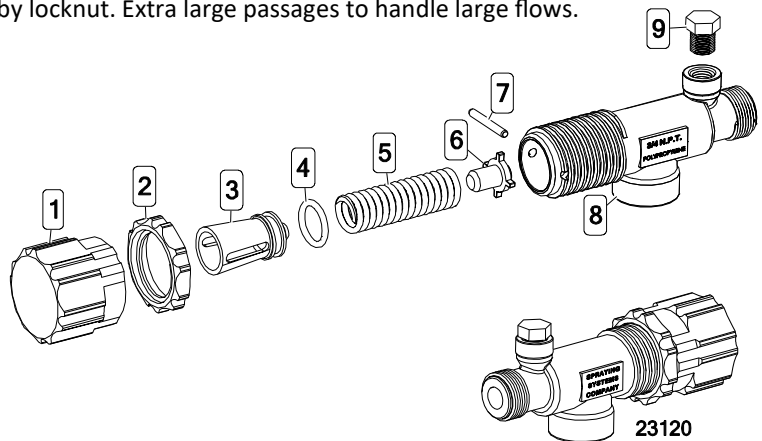

Ref. #	Part #	Mfg. Part #	Description
1	5046270	CP23122-NY	Adjusting Cap, Nylon (Gray)
2	5110266	CP23123-PP	Lock Ring
3	◆◆	CP23124-PP	Spring Retainer
4	**	CP7717-15-EPR	O-Ring, EPDM Rubber
5	**	CP23127-302SS	Spring
6	◆◆	CP23125-PP	Guide Seat
7	**	CP23126-302SS	Retaining Pin
8	CP23121-PP	CP23121-PP	Poly Body (3/4" NPT)
9	5102022	F14	Pipe Plug, 1/4" MNPT

Ref. #	Part #	Mfg. Part #	Description
1	5143199	23120-3/4-PP	Pressure Relief Valve, (3/4" NPT)
2	5168717	PK-AB23120-KIT	Repair Kit, Items Marked **

** Available ONLY in Repair Kit

◆◆ ONLY Available in Complete Assembly

TeeValve Control Valve Model: AA17L (5143295)

Model AA17L, used for selective control of 3-section boom sprayers at pressures up to 300 PSI.

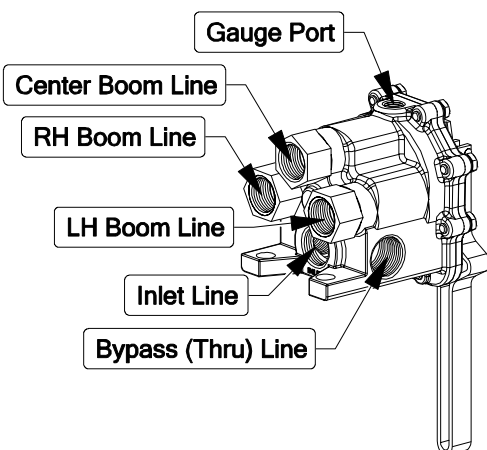

- Use to open any of three boom sections lines in any desired combination.
- Raise lever to open, lower lever to close the valve without changing the indexed position.
- Aluminum construction with stainless steel and plastic internal parts for maximum corrosion resistance.
- 3/4" NPT Inlet/Outlet, 3 boom outlet and accessory outlet.
- 1/4" NPT Gauge Port

Boom Indicator Markings

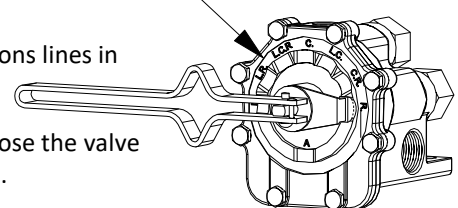

RH boom is 'selected'

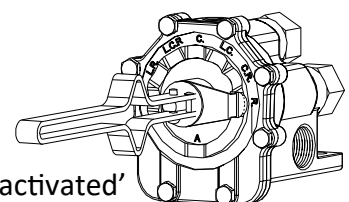

RH boom is 'activated'

Approx. Dimensions

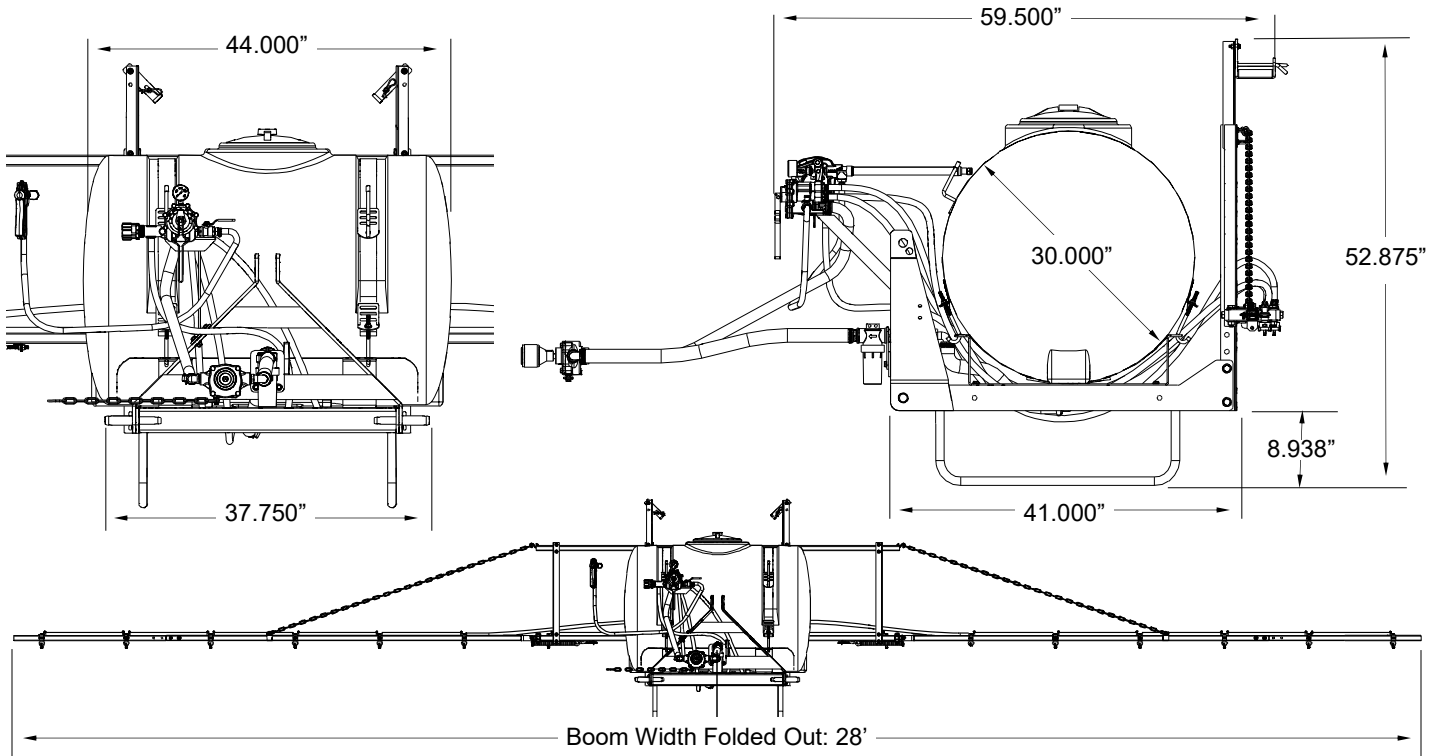

Troubleshooting

Symptom	Probable Cause(s)	Corrective Action
Pump Does Not Prime	Leak in suction line	Check hose and fittings for leaks and correct
	Obstruction in suction line	Inspect hose for debris or loose inner liner in hose
	Suction strainer clogged	Clean strainer
	Suction hose sucked to bottom or side of tank	Cut a notch or "V" in end of suction hose
	Air lock in pump	Run pump with discharge hose removed to clear air lock
	Pump worn	Replace or repair pump
	Rollers stuck in pump	Disassemble pump and inspect rollers
Loss of Pressure	Pump seals worn, leaking air	Replace seals
	Clogged suction strainer	Check strainer and clean it regularly
	Kinked or blocked suction hose	Inspect suction hose and repair as necessary
	Air leak in inlet side plumbing	Check hose and connections for leaks Use pipe joint sealant and retighten connections
	Relief valve setting too low or weakened spring	Check relief valve and correct setting
	Faulty Gauge	Replace gauge
	Pump seals leak air	Replace seals
Erratic Pressure Gauge Fluctuates Excessively	Nozzle orifices worn	Replace nozzles
	Pump worn	Repair pump
	Suction line has air leak	Tighten all fittings and hoses between pump and tank
	Debris in valve or gauge	Remove and clean parts
	Kinked or blocked suction hose	Remove suction line and clean-check tank and strainer
Pump will not turn	Air leak in suction hose	Tighten all fittings - replace hose if necessary
	Suction hose collapsed	Replace hose
Pump Leaks	Pump is sucking air or air has not been evacuated from strainer	Make sure suction hose is tightly secured. Run pump with discharge hose removed to remove air lock from pump
	Corrosion (rust), scale or residue	Loosen endplate bolts. Squirt oil into ports to help free rotor. Retighten bolts.
Excessive Vibration or Noisy Pump	Worn out seal	Replace seal
	Loose coupler or damaged shaft	Inspect shaft and tighten coupler
	Excessive PTO or engine speed	Reduce PTO or engine speed
	Rotor or internal problem	Replace rotor or pump
	Partially clogged strainer	Clean strainer
Pump Runs, but Low Pressure	Air leak in suction hose	Inspect suction hose - replace if necessary
	Debris in suction line	Clear debris
	Hose kinked	Straighten or replace hose if necessary
Pump Pressure Good, but Low Output Through Nozzles	Worn rollers	Replace rollers
	Strainer clogged	Clean strainer
	Nozzle size may be too small or clogged	Clean nozzles - replace nozzles if necessary
	Inlet line too small or blocked	Clear blockage and if necessary replace hose
	By-pass open too much	Close slightly

Warranty

LIMITED WARRANTY FOR NEW FIMCO, INC.

WHO MAY USE THIS LIMITED WARRANTY. This limited warranty (the "Limited Warranty") is provided by Fimco, Inc. to the original purchaser ("you") of the Equipment (as defined below) from Fimco, Inc. or one of Fimco, Inc.'s authorized dealers. This Limited Warranty does not apply to any subsequent owner or other transferee of the Equipment. THIS LIMITED WARRANTY GIVES YOU SPECIFIC LEGAL RIGHTS, AND YOU MAY ALSO HAVE OTHER RIGHTS WHICH VARY FROM STATE TO STATE.

WHAT THIS LIMITED WARRANTY COVERS AND FOR HOW LONG. Fimco, Inc. warrants that any new Equipment will be free from defects in material and workmanship for a period of **one (1) year** (homeowner), **90 days** (commercial user), after delivery of the Equipment to you (the "Warranty Period"). The Warranty Period is not extended if Fimco, Inc. repairs or replaces the Equipment.

WHAT IS NOT COVERED BY THIS LIMITED WARRANTY. This Limited Warranty does not apply to: (1) used Equipment; (2) any Equipment that has been altered, changed, repaired or treated since its delivery to you, other than by Fimco, Inc. or its authorized dealers; (3) damage or depreciation due to normal wear and tear; (4) defects or damage due to failure to follow Fimco, Inc.'s operator's manual, specifications or other written instructions, or improper storage, operation, maintenance, application or installation of parts; (5) defects or damage due to misuse, accident or neglect, "acts of God" or other events beyond Fimco, Inc.'s reasonable control; (6) accessories, attachments, tools or parts that were not manufactured by Fimco, Inc., whether or not sold or operated with the Equipment; or (7) rubber parts, such as tires, hoses and grommets.

HOW TO OBTAIN WARRANTY SERVICE. To obtain warranty service under this Limited Warranty, you must (1) provide written notice to Fimco, Inc. of the defect during the Warranty Period and within **thirty (30)** days after the defect becomes apparent or the repair becomes necessary, at the following address: Fimco, Inc., 1000 Fimco Lane, North Sioux City, SD 57049; and (2) make the Equipment available to Fimco, Inc. or an authorized dealer within a reasonable period of time. For more information about this Limited Warranty, please call: **800-831-0027**

WHAT REMEDIES ARE AVAILABLE UNDER THIS LIMITED WARRANTY. If the conditions set forth above are fulfilled and the Equipment or any part thereof is found to be defective, Fimco, Inc. shall, at its own cost, and at its option, either repair or replace the defective Equipment or part. Fimco, Inc. will pay for shipping and handling fees to return the repaired or replacement Equipment or part to you.

LIMITATION OF IMPLIED WARRANTIES AND OTHER REMEDIES. THE REMEDIES DESCRIBED ABOVE ARE YOUR SOLE AND EXCLUSIVE REMEDIES, AND FIMCO, INC.'S SOLE LIABILITY, FOR ANY BREACH OF THIS LIMITED WARRANTY. TO THE EXTENT APPLICABLE, ANY IMPLIED WARRANTIES, INCLUDING, WITHOUT LIMITATION, THE IMPLIED WARRANTIES OF MERCHANTABILITY AND FITNESS FOR A PARTICULAR PURPOSE, SHALL BE LIMITED IN DURATION TO THE WARRANTY PERIOD, AND THE REMEDIES AVAILABLE FOR BREACH THEREOF SHALL BE LIMITED TO THE REMEDIES AVAILABLE UNDER THIS EXPRESS LIMITED WARRANTY. SOME STATES DO NOT ALLOW LIMITATIONS ON HOW LONG AN IMPLIED WARRANTY LASTS, SO THE ABOVE LIMITATION MAY NOT APPLY TO YOU. IN NO EVENT SHALL FIMCO, INC.'S LIABILITY UNDER THIS LIMITED WARRANTY EXCEED THE ACTUAL AMOUNT PAID BY YOU FOR THE DEFECTIVE EQUIPMENT, NOR SHALL FIMCO, INC. BE LIABLE, UNDER ANY CIRCUMSTANCES, FOR ANY CONSEQUENTIAL, INCIDENTAL, SPECIAL OR PUNITIVE DAMAGES OR LOSSES, WHETHER DIRECT OR INDIRECT. SOME STATES DO NOT ALLOW THE EXCLUSION OR LIMITATION OF INCIDENTAL OR CONSEQUENTIAL DAMAGES, SO THE ABOVE LIMITATION OR EXCLUSION MAY NOT APPLY TO YOU.