

OWNER'S MANUAL

Model: 110-3PT-5880 (5300836)
(110 Gallon 3-Point Sprayer w/5880 'BoomJet' [Brass] Nozzle)

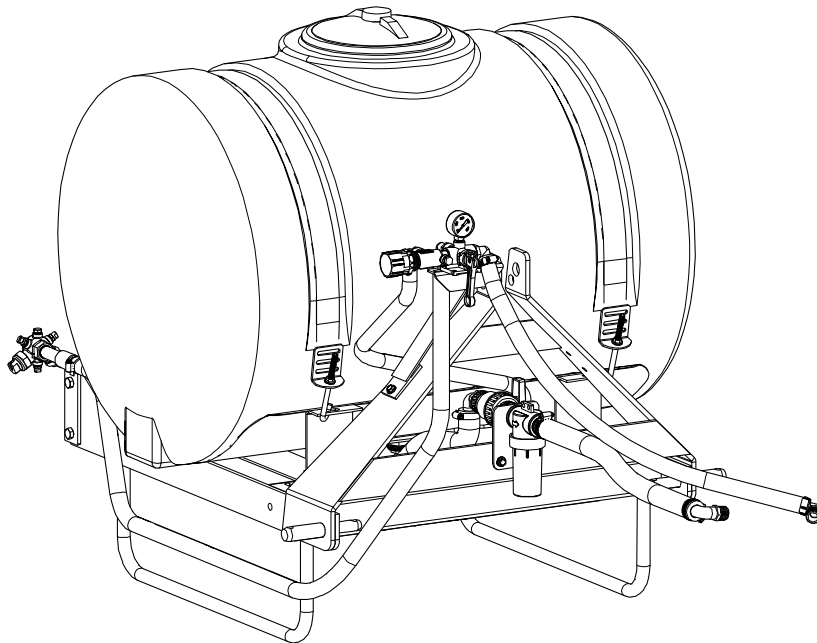

Category I or II

General Information

Thank you for purchasing this product. The purpose of this manual is to assist you in operating and maintaining your 3-Point sprayer.

**BEFORE RETURNING THIS PRODUCT
FOR ANY REASON, PLEASE CALL**

1-800-831-0027

MONDAY-FRIDAY, 8:00 AM TO 5:00 PM CST

If you should have a question or experience a problem with your Fimco Industries Product: Visit our website @ www.fimcoindustries.com or call the Toll free number above. Our technical support representatives will be happy to help you.

In most cases a customer service rep. can resolve the problem over the phone.

To obtain prompt, efficient service, always remember to give the following information....

- Correct Part Description and/or part number
- Model number and Serial Number

Part descriptions and numbers can be obtained from the illustrated parts list section(s) of this manual.

Retain a copy of your receipt for your unit, as it will be required to validate any warranty service.

Warranted against manufacturer or workmanship defects from date of purchase with copy of receipt:

Homeowner Usage: One Year.
Commercial Usage: 90 Days.



WARNING: Cancer and Reproductive Harm.
www.P65Warnings.ca.gov



WARNING: To reduce the risk of injury, the user must read and understand the operator's manual before using this product.



www.fimcoindustries.com

1000 FIMCO Lane, P.O. Box 1700, North Sioux City, SD 57049
Toll Free Phone: 800-831-0027 : Toll Free Fax: 800-494-0440
[5004642 (10/22)]

Contents

Technical Specs.....	2	Directo Valve Exploded View/Parts List	7
Sprayer Assembly Instructions	3	Sprayer Exploded View	8
Sprayer Info and Operation	4	Sprayer Parts List.....	9
Calibration	5	BoomJet Exploded View and Parts List	9
BoomJet 5880 Info and Rate Chart	5	Sprayer Dimensions	10
Maintenance, Tank Care and Winter Storage	6	Troubleshooting	11
Pressure Relief Valve Exploded View/Parts List	7	Warranty	12

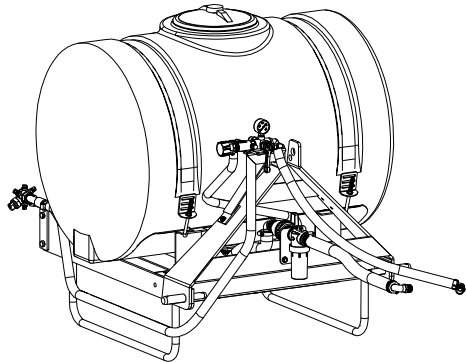

Model: 110-3PT-5880 (5300836)
(110 Gallon 3-Point Sprayer w/5880 'BoomJet' [Brass] Nozzle)

Technical Specifications

- 110 Gallon Polyethylene Tank
- Suction Line Filter
- 5880 'BoomJet' Nozzle

Caution: When fully filled with water, this sprayer will weigh approx. 1,110 lbs..
Consult the owner's manual for your vehicle to verify that you are within it's load carrying capacity.

~~~~~IMPORTANT~~~~~

Remove tank lid and be sure the tank is clean and free of any foreign material. Rinse tank out of any tank residue before filling with water to test.

~~~~~IMPORTANT~~~~~

It is VERY important for you to test your sprayer with plain water before actual spraying is attempted. This will enable you to check the sprayer for leaks without the possibility of losing any expensive chemicals.

~~~~~WARNING~~~~~



Read and Understand the Owner's Manual before using this sprayer. Test and use in accordance to instructions.
Read and Follow chemical label instructions and wear protective gear when filling, using, cleaning and servicing the sprayer.

Exercise Caution in vehicle handling when towing/hauling a filled sprayer to avoid loss of control or overturning.

Keep Sprayer and Spray materials away from other people, children and pets.

Do Not Turn on Power to the sprayer, until ready to spray in order to avoid unintentional spray release.

Do Not Use on steep slopes. A full sprayer could cause loss of control or overturn sprayer and vehicle.

Always operate up and down a slope, never across the face of a slope.

Keep all movement on slopes slow and gradual. Do not make sudden changes in speed, directions or turning. Do not start or stop suddenly when going uphill or downhill.

Stop on level ground, set the parking brake and shut off engine before leaving the operator's position for any reason.

Keep all parts in good condition and properly installed. Fix damaged or worn parts immediately.

Caution should be taken when towing and/or using any sprayer. This sprayer combined with the weight distribution, turning radius and speed of vehicle can result in damage to vehicle and/or sprayer or severe injury or death, if not used properly.

Improper use of this sprayer or handling of chemicals could result in serious injury or illness, or could cause damage to the environment.

Assembly Procedure

Most of the sprayer has been assembled at the factory.

- Follow the steps below to properly assemble the sprayer.

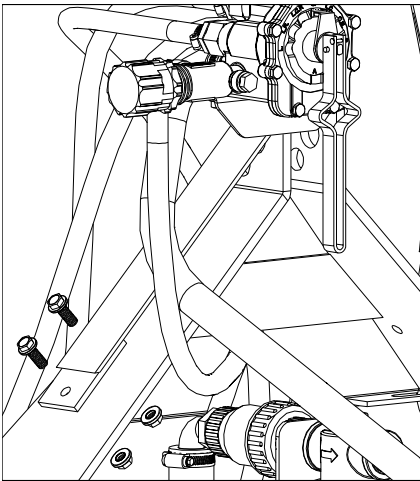

1. Install the pre-assembled tee valve sub-assembly to the 3-point carrier valve mount and position as shown.

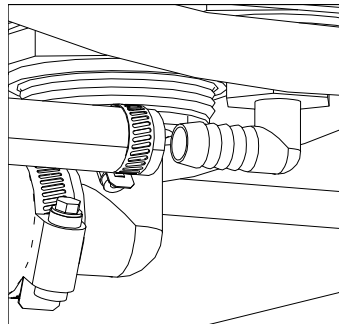

2. Slide a hose clamp on to the bypass hose (from the relief valve), then with a twisting motion, slip the bypass hose over the fitting on the bottom of the tank. Slide the hose clamp to the end of the hose and secure.

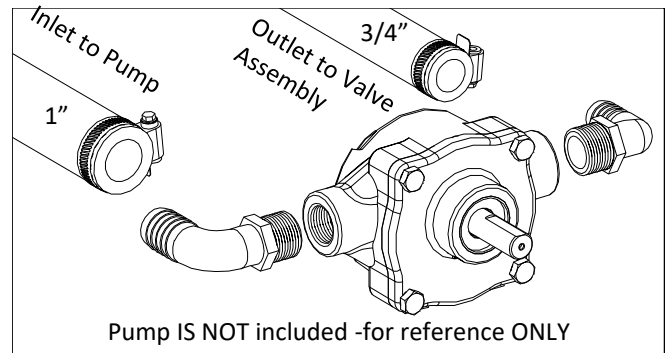

4. Using a good quality thread sealant, thread the 1" fitting into the inlet (IN) side of your pump and the 3/4" fitting to the outlet (OUT) side of the pump. With a twisting motion, attach the other end of the 1" hose to the 1" fitting on the inlet to the pump. Slip a 3/4" hose clamp onto the 3/4" hose coming off the valve assembly and with a twisting motion, attach hose to the output side of the pump and secure with the hose clamp.

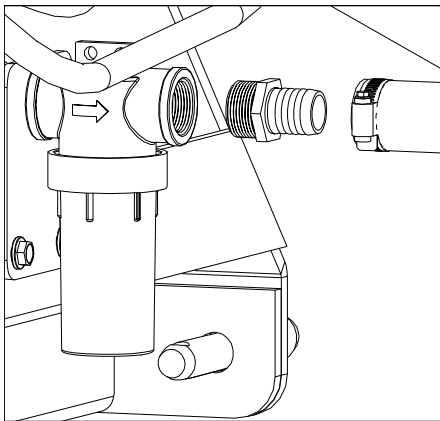

3. Using a good quality thread sealant, carefully thread the 1" fitting into the strainer. Find the 1" x 36" pump feeder hose. Slip a hose clamp onto the ends of the hose. With a twisting motion, slip the hose all the way onto the fitting and secure with the hose clamp.

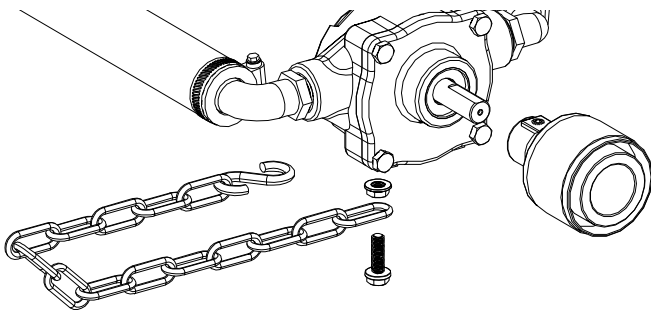

Pump & Coupler ARE NOT included -for reference ONLY

5. The roller pump IS NOT included with the assembly. Attach the adapter, the torque chain and S-hook to the pump as needed. It is intended for your pump to be mounted directly to the tractor PTO. The torque chain needs to be secured to the tractor to keep your pump from spinning.

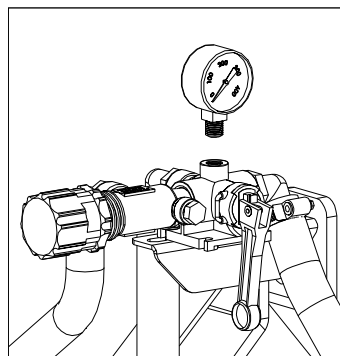

6. Using sealant thread the gauge into the top of the Directo Valve assembly.

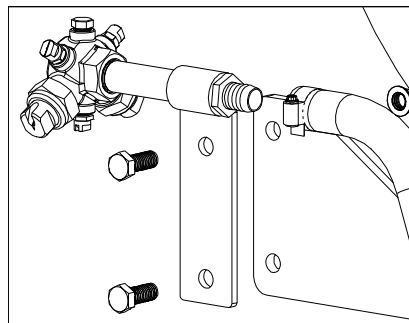

7. There is another 3/4" hose coming off the output side of the Directo-Valve. This hose needs to be connected to the fitting on the BoomJet nozzle assembly. Move the coupling mount into an upright position and fasten with the (2) bolts and (2) nuts.

- Make sure all hose clamps are tight before testing or spraying for the first time.

**** The Sprayer is now ready to TEST w/plain water before actual use ****

Operation Instructions

Information About the Sprayer

Roller pumps are positive displacement pumps, which means that the entire solution being pumped must go somewhere or the pump will break. In this roller pumping system, solution is drawn from the tank and forced to a planned source, such as boom nozzles or handgun. The pressure is controlled by a pressure relief valve, which is a spring-loaded device that controls the amount of fluid bypassed (recirculated) to the tank. The gray handle is to be tightened to increase pressure and loosened to decrease pressure. The 'directo-valve' is the on/off control which allows the operator to manually control the solution going to the boom.

IMPORTANT: Remove tank lid and be sure the tank is clean and free of any foreign material. Rinse tank out of any tank residue before filling with water to test.

Testing the Sprayer

Attach the sprayer to the tractor 3 point hitch. Mount the pump to the PTO and affix the torque chain.

NOTE: It is important to test the sprayer with plain water before actual spraying is attempted. This will enable you to familiarize yourself and check for leaks without the possibility of losing any expensive chemicals.

Fill the tank about 1/2 full with plain water. Before starting, open the suction line valve (located underneath the carrier frame), turn the relief valve handle out to lower the line pressure. This will help prime the pump.

CAUTION: Always be sure that the water (or solution) has reached the pump before starting your sprayer. If the pump is allowed to run dry, serious damage to the pump will result.

Always have the pressure line open to the tips so that the air which may be trapped in the line will be forced (or purged) out. Start the tractor PTO. Check the entire system for leaks. Once the pump is primed, the pressure may be increased by turning the handle of the pressure relief valve in. Keep the pressure line open to the tips when setting the pressure. Set the pressure and then lock the relief valve handle in place. Shut off the directo-valve and check for leaks again. Pressure will increase when the pressure line valve is closed and then return to the preset pressure when the valve is opened again.

During the testing period, be sure to observe the spray pattern given by the spray nozzles. If there is any pattern distortion, it will be necessary to remove and clean the affected tips.

Caution: Never use a metal object or other sharp item for cleaning a nozzle tip. It is better to use a nozzle brush (NOT wire brush) or compressed air for tip cleaning.

Conditions of weather and terrain must be considered when setting the sprayer. Do not spray on windy days. Protective clothing must be worn in some cases

Be sure to read the chemical label(s) before application!

Operation

The performance of any agricultural chemical depends upon the proper application.

Always fill the tank with a desired amount of water first and then add the chemical slowly, mixing as you pour the chemical into the tank. You may use the handgun to spraying into the solution in order to mix the chemical and water.

Only fill the tank with what you're going to spray in a day, never leave chemicals sit in tank.

Calibration

Chemical labels may show application rates in gallons per acre, gallons per 1000 square feet or gallons per 100 square feet. You will note that the tip chart shows gallons per acre. Once you know how much you are going to spray, then determine (from the tip chart) the spraying pressure (PSI), and the spraying speed (MPH).

Determining the proper speed of the pulling vehicle can be done by marking off 100, 200 & 300 feet. The speed chart indicates the number of seconds it takes to travel the distances. Set the throttle and with a running start, travel the distances. Adjust the throttle until you travel the distances in the number of seconds indicated by the speed chart. Once you have reached the throttle setting needed, mark the throttle location so you can stop and go again, returning to the same speed.

Add water and proper amount of chemical to the tank and drive to the starting place for spraying

The 5880 BoomJet nozzle is used for spraying areas not easily accessed with a boom sprayer. Combines (2) off-center tips and (3) VeeJet® nozzles to produce a wide swath flat spray. While not as uniform as a boom sprayer, the BoomJet provides good distribution.

The 5880 BoomJet nozzle combines (2) off-center tips and (3) VeeJet nozzles to produce an overall wide swath flat spray. The nozzle assembly provides a good distribution for the wide pattern coverage obtained.



W = Maximum effective coverage with

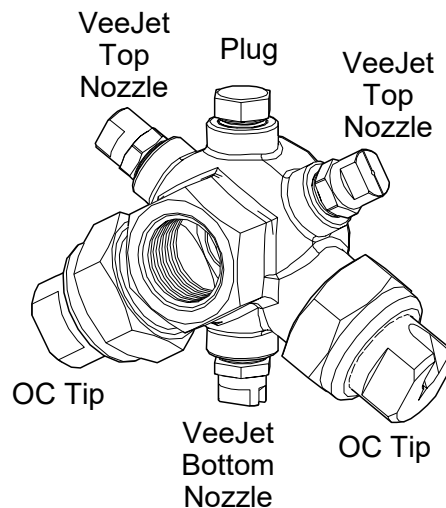

BoomJet Nozzle No.	OC Tips (2)	VeeJet Top Nozzles (2)	VeeJet Bottom Nozzle	Liquid Pressure (PSI)	Total Capacity (GPM)	"W" in Feet	Gallons Per Acre				
							4 MPH	5 MPH	7.5 MPH	10 MPH	15 MPH
5880-3/4-2TOC10 (Fimco #5138475)	OC10 (#5138899)	H1/4U-0508HE (Fimco #5138691)	H1/4VVL-11004	20	2.83	39.5	8.9	7.1	4.7	3.5	2.4
				30	3.46	40	10.7	8.6	5.7	4.3	2.9
				40	4.00	40.5	12.2	9.8	6.5	4.9	3.3

Features a 1/4" gauge port and is supplied with (1) additional 1/4" NPT pipe plug (#CP2812) and (1) blank tip (#5138668) for allowing the BoomJet to spray to one side only.

Speed Chart			
Speed in M.P.H. (Miles Per Hour)	Time Required in seconds to travel a distance of		
	100 Ft.	200 Ft.	300 Ft.
1.0	68 sec.	136	205
2.0	34	68	102
3.0	23	45	68
4.0	17	34	51
5.0	14	27	41
6.0	11	23	34
7.0	9.7	19	29
8.0	8.5	17	26
9.0	7.6	15	23
10.0	6.8	14	20

Using the Boom Nozzles

Four things must be considered before spraying with the boom.

1. How much chemical must be mixed in the tank.
 2. Rate of spray (gallons per acre to be sprayed).
 3. What pressure (p.s.i.) will be used.
 4. Speed traveled (mph) while spraying.
- * Refer to the chemical label to determine your chemical mixture
 - * See the tip chart to determine the pressure to be used. The chart will also show the speed used when spraying.
 - * Start the pump and open the valve to the boom nozzles.
 - * Check the spray pattern. Usually you can see the coverage better on a solid concrete surface, such as a driveway.

Spraying Solutions Other Than Water

Since all the tabulations are based on spraying water, which weighs 8.34 lbs. per USA gallon, conversion factors must be used when spraying solutions which are heavier or lighter than water. To determine the proper size nozzle for the solution to be sprayed, first multiply the desired GPM or GPA of solution by the rate conversion factor. Then use the new converted GPM or GPA rate to select the proper size nozzle.

Example: Desired application rate is 20 GPA of 28% Nitrogen.

Determine the correct nozzle size as follows:

GPA (Solution) x Conversion Factor = GPA

20 GPA (28%) x 1.13 = 22.6 GPA (Water)

The applicator should choose a nozzle size that will supply 22.6 GPA of water at the desired pressure.

Weight of Solution	Specific Gravity	Conversion Factors
7.0 lbs. per gallon	.84	.92
8.0 lbs. per gallon	.96	.98
8.345 lbs. per gallon (Water)	1.00	1.00
9.0 lbs. per gallon	1.08	1.04
10.0 lbs. per gallon	1.20	1.10
10.66 lbs. per gallon (28% Nitrogen)	1.28	1.13
11.0 lbs. per gallon	1.32	1.15
12.0 lbs. per gallon	1.44	1.20
14.0 lbs. per gallon	1.68	1.30

Miscellaneous Conversion Factors

One Acre = 43,560 square feet = 0.405 Hectare

One Hectare = 2.471 Acres

One Gallon Per Acre = 9.35 Liters Per Hectare

One Mile = 5,280 Feet = 1,610 Meters = 1.61 Kilometers

One Gallon = 128 Fluid Ounces = 8 Pints = 4 Quarts = 3.79 Liters = 0.83 Imperial Gallons

One Pound Per Square Inch = 0.069 bar. = 6.895 Kilopascals

One Mile Per Hour = 1.609 Kilometers Per Hour

Higher pressure not only increases the flow rate of the nozzle, but it also influences the droplet size and the rate of orifice wear. As pressure is increased, the droplet size decreases and the rate of orifice wear is increased. The values given in the tabulation section of this owners manual indicate the most commonly used pressure ranges for the associated spray tips.

Tank Care & Maintenance

Warning: Do not use the tank as a container for fuel oils, kerosene, gasoline or any other petroleum distillate product. All polyolefins are softened and permeated by such products. In an enclosed area the vaporization of these materials from the outside surface of the tank could create a dangerous condition.

The tank should not be used as a pressure vessel nor used with chemicals or solutions having a weight of more than 12 pounds per gallon.

Store the tank in a dry dark place when not in use. Storage out of sunlight will prolong the life of the tank.

Do not drop, strike or kick the tank, especially at low temperatures. Tanks become brittle and are subject to cracking at temperatures below 20° Fahrenheit.

Always flush the tank with water and a neutralizing agent at the end of each use, to prevent contamination of solutions.

Maintenance During/After Spraying

Periodically close the suction line valve and check the strainer and clean the screen.

Proper care and maintenance will prolong the life of your sprayer.

After use, fill the sprayer tank part way with water. Start the sprayer and allow the clear water to be pumped through the plumbing system and out through the spray nozzles. Refill the tank about half full with plain water and use FIMCO Tank Neutralizer and Cleaner and repeat cleaning instructions above (If no tank cleaner is available, you may substitute dish soap for this step, about 1-2 oz. per gallon). But a neutralizer/cleaner should be used to thoroughly clean the system. Flush the entire sprayer with the neutralizing/cleaning agent, then flush out one more time with plain water. Follow the chemical manufacturer's disposal instructions of all wash or rinsing water. For the boom (if applicable) remove the tips and screens from the nozzle assemblies. Wash these items out thoroughly. Blow the orifice clean and dry. If the orifice remains clogged, clean it with a fine bristle (NOT WIRE) brush or with a toothpick. Do not damage the orifice. Water rinse and dry the tips before storing.

WARNING: Some chemicals will damage the pump valves if allowed to soak untreated for a length of time! ALWAYS flush the pump as instructed after each use. DO NOT allow chemicals to sit in the pump for extended times of idleness. Follow the chemical manufacturer's instructions on disposal of all waste water from the sprayer.

Winter Storage

Drain all water out of your sprayer, paying special attention to the pump, handgun and valve(s). These items are especially prone to damage from chemicals and freezing weather.

The sprayer should be winterized before storage by pumping a solution of automotive antifreeze (containing a rust inhibitor) through the entire plumbing system. This antifreeze solution should remain in the plumbing system during the winter months.

When spring time comes and you are preparing your sprayer for the spray season, rinse the entire plumbing system out, clearing the lines of the antifreeze solution. Proper care and maintenance will prolong the life of your sprayer.

Piston Type Pressure Relief/Regulating Valves

Bypasses excess fluid. Adjustable to maintain control of line pressure at any pressure within the valve operating range.
Selected pressure setting firmly held in place by locknut. Extra large passages to handle large flows.

- Polypropylene with stainless steel spring
- Excellent chemical resistance
- EPDM O-Rings
- Fore pressure to 150 p.s.i.
- 1/4" port for pressure gauge
- 3/4" NPT (M) inlet & (F) outlet connections

Ref. #	Part #	Mfg. Part #	Description
1	5046270	CP23122-NY	Adjusting Cap, Nylon (Gray)
2	5110266	CP23123-PP	Lock Ring
3	◆◆	CP23124-PP	Spring Retainer
4	**	CP7717-15-EPR	O-Ring, EPDM Rubber
5	**	CP23127-302SS	Spring
6	◆◆	CP23125-PP	Guide Seat
7	**	CP23126-302SS	Retaining Pin
8	CP23121-PP	CP23121-PP	Poly Body (3/4" NPT)
9	5102022	F14	Pipe Plug, 1/4" MNPT

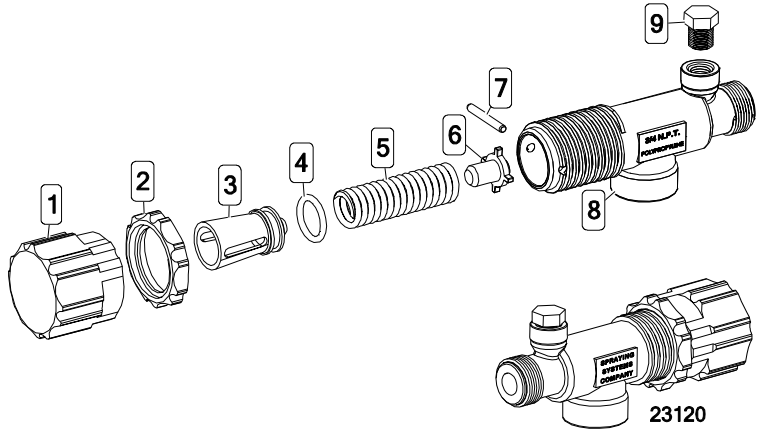

Ref. #	Part #	Mfg. Part #	Description
1	5143199	23120-3/4-PP	Pressure Relief Valve, (3/4" NPT)
2	5168717	PK-AB23120-KIT	Repair Kit, Items Marked **

** Available only in Repair Kit
◆◆: Only Available in Complete Assembly

'Directo Valve' - Manually Operated Control Valve

- Corrosion Resistant Materials: Wetted Parts Polypropylene, 316SS and Polyethylene
- Maximum Pressure = 150 p.s.i.
- Large Capacity - 12.5 G.P.M. @ 5 p.s.i. Pressure Drop
- 3/4" NPT (F) Inlet Connection
- 1/2" NPT (F) Spray Line Connection
- 3/4" NPT (F) Continuous By-Pass Connection
- Valves may be connected w/close nipples for multiple section spray control

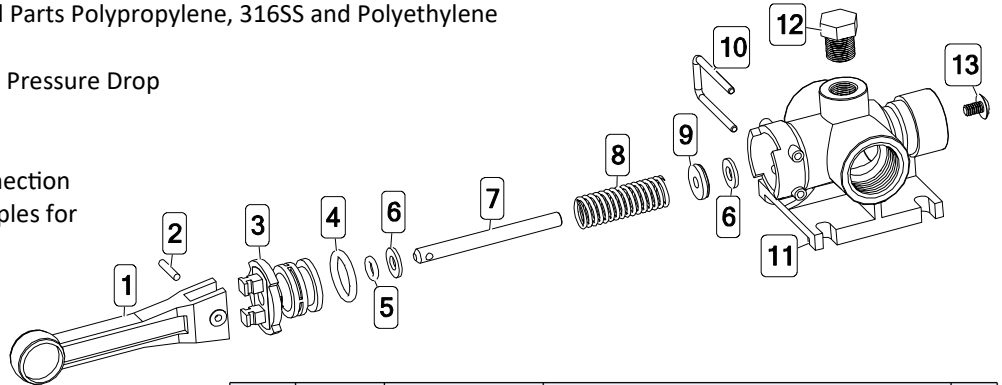

Fimco #	Mfg. Part #	Description
5143316	AA6B	Directo-Valve (AA6B)
5168718	PK-AB6B-KIT	Repair Kit, Items Marked **

Ref. #	Part #	Mfg. Part #	Description	Qty
1	5078178	CP36301-NY	Handle (Gray)	1
2	5101220	CP36308-SS	Groove Pin	1
3	5086043	CP36302-PP	Poly Body Insert, (Black)	1
4	**	CP7717-2/209-VI	O-Ring, Viton	1
5	**	CP7717-2/108-VI	O-Ring, Viton	1
6	◆◆	CP36307-PPB	Washer	2
7	◆◆	CP36304-SS	Stem	1
8	◆◆	CP36306-302SS	Spring	1
9	**	CP38726-VI	Shut-Off Washer, Viton	1
10	◆◆	CP36309-302SS	Retaining Clip	1
11	5002476	CP36303-PP	Poly Body (AA6B)	1
12	5102022	F14	Pipe Plug, 1/4" MNPT	1
13	5117281	CP38725-SS	#10-24 x 5/16" Phillips Truss Head Mach. Screw	1

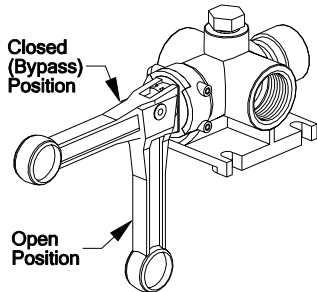

** Available only in Repair Kit
◆◆: Only Available in Complete Assembly

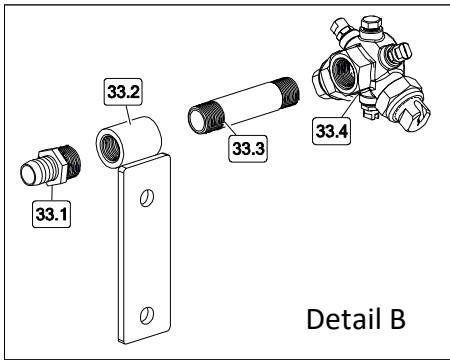

Detail B

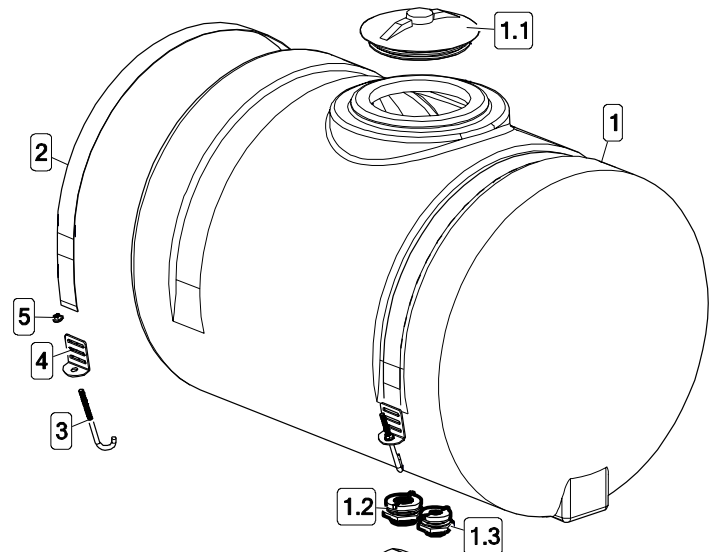

**Exploded View:
110-3PT-5880
(5300836)**

Refer to the parts list
next page for part numbers.

See
Detail A

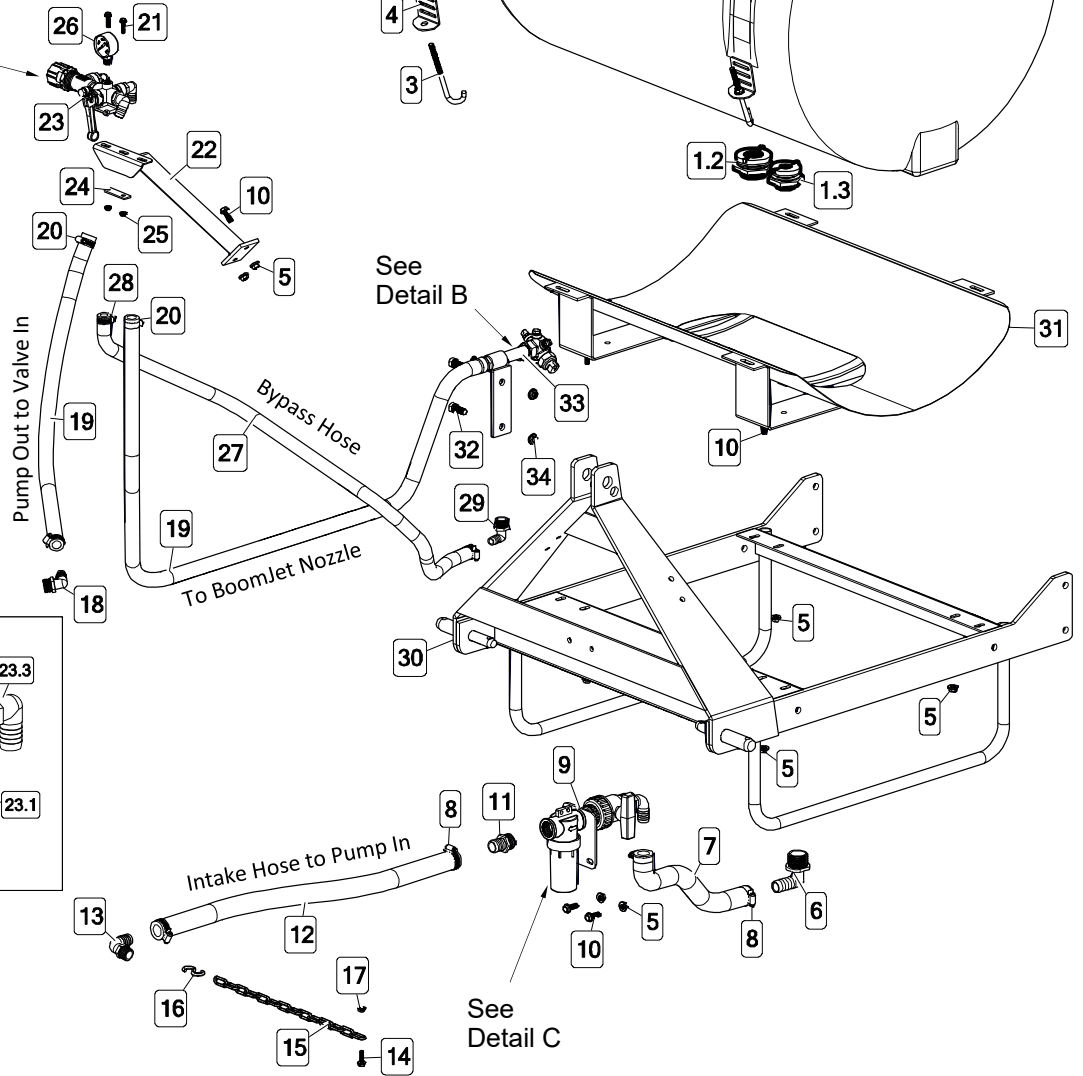

See
Detail B

See
Detail C

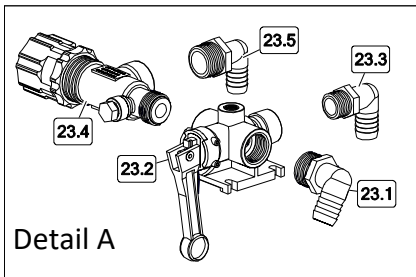

Detail A

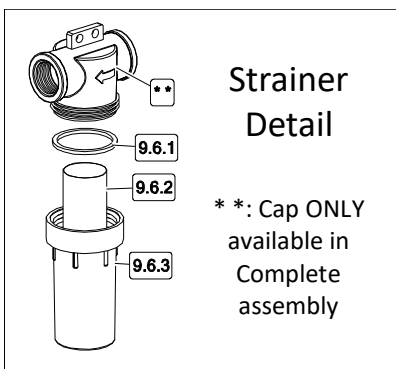

**Strainer
Detail**

** : Cap ONLY
available in
Complete
assembly

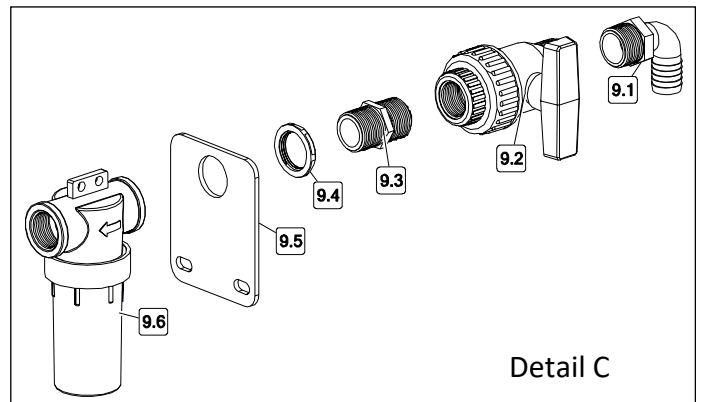

Detail C

Parts List: 110-3PT-5880 (5300836)

Ref. #	Part #	Description	Qty
1	5169003	110 Gallon Tank (30" Dia.)	1
1.1	63480	8" Lid w/Blue Snap-In Vent	1
1.2	5274362	1-1/4" Double-Threaded Bulkhead	1
1.3	5273736	3/4" Double-Threaded Bulkhead	1
2	5133101	Nylon Strap (2" x 72")	2
3	5034173	3/8-16 x 5.50 Hook Bolt	4
4	5108041-BLK	Tank Strap Buckle, Bent	4
5	5006259	3/8-16 Serrated Fling Hex Nut	12
6	5010215	Poly Elbow, 1 1/4" MNPT x 1" HB	1
7	5020315	Hose, 1"-2 Brd. x 24"	1
8	5051025	Hose Clamp (1 Inch)	4
9	5274765	Strainer Sub-Assembly	1
9.1	5010213	Poly Elbow, 1" MNPT x 1" HB	1
9.2	5143207	1" Single Union Ball Valve	1
9.3	5011141	Poly Close Nipple, 1" MNPT	1
9.4	5006394	1" NPT Mylon Lock Nut	1
9.5	5038247-BLK	Strainer Bracket	1
9.6	5116441	1" Nylon Strainer (Black, 40 Mesh)	1
9.6.1	5072229	EPDM Gasket	1
9.6.2	5116180	Screen (40 Mesh)	1
9.6.3	5058075	Strainer Bowl	1
10	5117307	3/8-16 x 1.00 Fling Hex Bolt	8
11	5067118	Poly Fitting, 1" MNPT x 1" HB	1
12	5020338	Hose, 1"-2 Brd. x 36"	1
13	5010210	Poly Elbow, 3/4" MNPT x 1" HB	1
14	5117300	5/16-18 x 1.00 Fling Hex Bolt	1
15	5049017	Torque Chain, 24"	1
16	5082006	"S" Hook	1

Ref. #	Part #	Description	Qty
17	5006307	5/16-18 Serrated Fling Hex Nut	1
18	5010209	Poly Elbow, 3/4" MNPT x 3/4" HB	1
19	5020179	Hose, 3/4"-2 Brd. x 6 Ft. (72")	2
20	5051024	Hose Clamp (3/4)	4
21	5117301	1/4-20 x 1.00 Fling Hex Bolt	2
22	5271771-BLK	Valve Mount	1
23	5275072	Directo Valve Sub-Assembly	1
23.1	5010209	Nylon Elbow, 3/4" MNPT x 3/4" HB	1
23.2	5143316	Directo-Valve (AA6B)	1
23.3	5010205	Nylon Elbow, 1/2" MNPT x 3/4" HB	1
23.4	5143199	Pressure Relief Valve, (3/4" NPT)	1
23.5	5020208	Nylon Elbow, 3/4" MNPT x 5/8" HB	1
24	5017597-BLK	Clamp Plate for Directo Valve	1
25	5006306	1/4-20 Serrated Fling Hex Nut	2
26	5167005	Gauge, 0-400 PSI (Dry)	1
27	5020117	Hose, 5/8"-1 Brd. x 4 Ft. (48")	1
28	5051023	Hose Clamp (5/8)	2
29	5010208	Poly Elbow, 3/4" MNPT x 5/8" HB	1
30	5271770-RED	3-Point Mounting Weldment (27-D)	1
31	5273904-BLK	Saddle Weldment (30"-110 Gallon)	1
32	5034019	1/2-13 x 1.25 Hex Bolt	2
33	5275073	Boomjet Nozzle Sub-Assembly	1
33.1	5010020	Nylon Fitting, 3/4" MNPT x 3/4" HB	1
33.2	5273741-BLK	Coupling Mount Weldment	1
33.3	5011060	4" (Galv.) Pipe Nipple, 3/4" MNPT	1
33.4	5138475	Boomjet Nozzle (Brass)	1
34	5006337	1/2-13 Serrated Fling Hex Nut	2

BoomJet® Boomless Nozzle Detail

Item #	Mfg. Part #	Fimco #	Description
1	CP2812	CP2812	1/4" Pipe Plug, Brass
2	H1/4U-0508HE	5138691	VeeJet® Nozzle, Brass
3	CP5856	**	Nozzle Body, Brass
4	12687-50	5116263	Strainer, 50 Mesh
5	H1/4VV-11004	5138722	VeeJet® Nozzle, Brass
6	CP4784-AL	5072106	Tip Gasket, Aluminum
7	OC10	5138899	Off-Center Tip, Brass
8	CP3819	5046062	Cap, Brass
9	CP5539	5138668	Tip Plug, Brass (Blank for OC Tip)

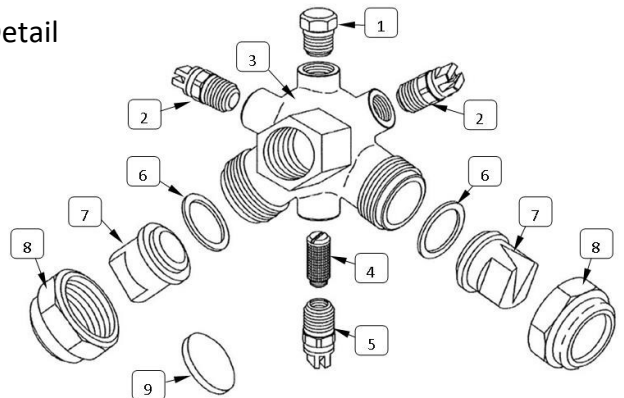

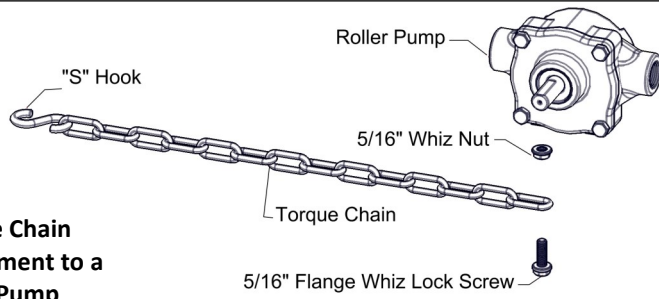

Torque Chain Attachment to a Roller Pump

Torque chain, 'S' hook, nut and bolt are included to secure your pump during operation.

1. Attach end of the torque chain over stem of bolt
2. Thread the whiz nut onto the bolt. Hand-tighten.
3. Thread 'pre-assembly' into the threaded hole on the underside of the pump. Tighten sufficiently
4. Affix the 'S' Hook and wrap the chain around the frame or hitch and 'S-Hook' it in place. Make sure connection is very secure! If not secured, it may result in the pump spinning on PTO shaft and damaging some components of your sprayer.

*** Insure that this connection point will not allow the roller pump to spin on the PTO shaft ***

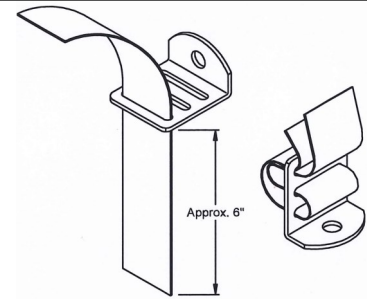

Strap/Buckle Detail
Strap Attachment to a "Bent" Buckle

The nylon straps are to be inserted in and out of the slots in the buckle, as shown. Be sure the straps are snug before tightening the hook bolts. In most cases, it will be necessary to re-tighten the straps after filling the tank with liquid.

Dimensions:

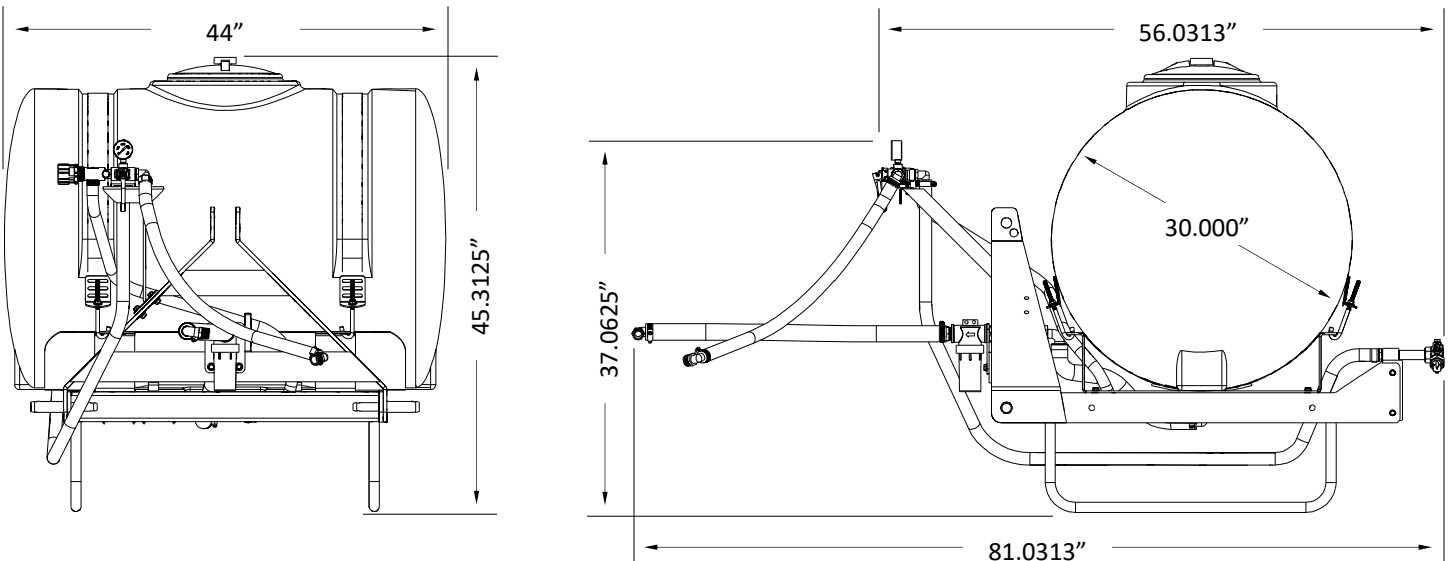

Troubleshooting		
Symptom	Probable Cause(s)	Corrective Action
Pump Does Not Prime	Leak in suction line	Check hose and fittings for leaks and correct
	Obstruction in suction line	Inspect hose for debris or loose inner liner in hose
	Suction strainer clogged	Clean strainer
	Suction hose sucked to bottom or side of tank	Cut a notch or "V" in end of suction hose
	Air lock in pump	Run pump with discharge hose removed to clear air lock
	Pump worn	Replace or repair pump
	Rollers stuck in pump	Disassemble pump and inspect rollers
	Pump seals worn, leaking air	Replace seals
Loss of Pressure	Clogged suction strainer	Check strainer and clean it regularly
	Kinked or blocked suction hose	Inspect suction hose and repair as necessary
	Air leak in inlet side plumbing	Check hose and connections for leaks Use pipe joint sealant and retighten connections
	Relief valve setting too low or weakened spring	Check relief valve and correct setting
	Faulty Gauge	Replace gauge
	Pump seals leak air	Replace seals
	Nozzle orifices worn	Replace nozzles
	Pump worn	Repair pump
Erratic Pressure Gauge Fluctuates Excessively	Suction line has air leak	Tighten all fittings and hoses between pump and tank
	Debris in valve or gauge	Remove and clean parts
	Kinked or blocked suction hose	Remove suction line and clean-check tank and strainer
	Air leak in suction hose	Tighten all fittings - replace hose if necessary
	Suction hose collapsed	Replace hose
	Pump is sucking air or air has not been evacuated from strainer	Make sure suction hose is tightly secured. Run pump with discharge hose removed to remove air lock from pump
Pump will not turn	Corrosion (rust), scale or residue	Loosen endplate bolts. Squirt oil into ports to help free rotor. Retighten bolts.
	Solid object lodged in pump.	Disassemble pump and remove objects
Pump Leaks	Worn out seal	Replace seal
Excessive Vibration or Noisy Pump	Loose coupler or damaged shaft	Inspect shaft and tighten coupler
	Excessive PTO or engine speed	Reduce PTO or engine speed
	Rotor or internal problem	Replace rotor or pump
	Partially clogged strainer	Clean strainer
	Air leak in suction hose	Inspect suction hose - replace if necessary
Pump Runs, but Low Pressure	Debris in suction line	Clear debris
	Hose kinked	Straighten or replace hose if necessary
	Worn rollers	Replace rollers
	Strainer clogged	Clean strainer
Pump Pressure Good, but Low Output Through Nozzles	Nozzle size may be too small or clogged	Clean nozzles - replace nozzles if necessary
	Inlet line too small or blocked	Clear blockage and if necessary replace hose
	By-pass open too much	Close slightly

Warranty

LIMITED WARRANTY FOR NEW FIMCO, INC.

WHO MAY USE THIS LIMITED WARRANTY. This limited warranty (the "Limited Warranty") is provided by Fimco, Inc. to the original purchaser ("you") of the Equipment (as defined below) from Fimco, Inc. or one of Fimco, Inc.'s authorized dealers. This Limited Warranty does not apply to any subsequent owner or other transferee of the Equipment. THIS LIMITED WARRANTY GIVES YOU SPECIFIC LEGAL RIGHTS, AND YOU MAY ALSO HAVE OTHER RIGHTS WHICH VARY FROM STATE TO STATE.

WHAT THIS LIMITED WARRANTY COVERS AND FOR HOW LONG. Fimco, Inc. warrants that any new Equipment will be free from defects in material and workmanship for a period of **one (1) year** (homeowner), **90 days** (commercial user), after delivery of the Equipment to you (the "Warranty Period"). The Warranty Period is not extended if Fimco, Inc. repairs or replaces the Equipment.

WHAT IS NOT COVERED BY THIS LIMITED WARRANTY. This Limited Warranty does not apply to: (1) used Equipment; (2) any Equipment that has been altered, changed, repaired or treated since its delivery to you, other than by Fimco, Inc. or its authorized dealers; (3) damage or depreciation due to normal wear and tear; (4) defects or damage due to failure to follow Fimco, Inc.'s operator's manual, specifications or other written instructions, or improper storage, operation, maintenance, application or installation of parts; (5) defects or damage due to misuse, accident or neglect, "acts of God" or other events beyond Fimco, Inc.'s reasonable control; (6) accessories, attachments, tools or parts that were not manufactured by Fimco, Inc., whether or not sold or operated with the Equipment; or (7) rubber parts, such as tires, hoses and grommets.

HOW TO OBTAIN WARRANTY SERVICE. To obtain warranty service under this Limited Warranty, you must (1) provide written notice to Fimco, Inc. of the defect during the Warranty Period and within **thirty (30)** days after the defect becomes apparent or the repair becomes necessary, at the following address: Fimco, Inc., 1000 Fimco Lane, North Sioux City, SD 57049; and (2) make the Equipment available to Fimco, Inc. or an authorized dealer within a reasonable period of time. For more information about this Limited Warranty, please call: **800-831-0027**

WHAT REMEDIES ARE AVAILABLE UNDER THIS LIMITED WARRANTY. If the conditions set forth above are fulfilled and the Equipment or any part thereof is found to be defective, Fimco, Inc. shall, at its own cost, and at its option, either repair or replace the defective Equipment or part. Fimco, Inc. will pay for shipping and handling fees to return the repaired or replacement Equipment or part to you.

LIMITATION OF IMPLIED WARRANTIES AND OTHER REMEDIES. THE REMEDIES DESCRIBED ABOVE ARE YOUR SOLE AND EXCLUSIVE REMEDIES, AND FIMCO, INC.'S SOLE LIABILITY, FOR ANY BREACH OF THIS LIMITED WARRANTY. TO THE EXTENT APPLICABLE, ANY IMPLIED WARRANTIES, INCLUDING, WITHOUT LIMITATION, THE IMPLIED WARRANTIES OF MERCHANTABILITY AND FITNESS FOR A PARTICULAR PURPOSE, SHALL BE LIMITED IN DURATION TO THE WARRANTY PERIOD, AND THE REMEDIES AVAILABLE FOR BREACH THEREOF SHALL BE LIMITED TO THE REMEDIES AVAILABLE UNDER THIS EXPRESS LIMITED WARRANTY. SOME STATES DO NOT ALLOW LIMITATIONS ON HOW LONG AN IMPLIED WARRANTY LASTS, SO THE ABOVE LIMITATION MAY NOT APPLY TO YOU. IN NO EVENT SHALL FIMCO, INC.'S LIABILITY UNDER THIS LIMITED WARRANTY EXCEED THE ACTUAL AMOUNT PAID BY YOU FOR THE DEFECTIVE EQUIPMENT, NOR SHALL FIMCO, INC. BE LIABLE, UNDER ANY CIRCUMSTANCES, FOR ANY CONSEQUENTIAL, INCIDENTAL, SPECIAL OR PUNITIVE DAMAGES OR LOSSES, WHETHER DIRECT OR INDIRECT. SOME STATES DO NOT ALLOW THE EXCLUSION OR LIMITATION OF INCIDENTAL OR CONSEQUENTIAL DAMAGES, SO THE ABOVE LIMITATION OR EXCLUSION MAY NOT APPLY TO YOU.