

OWNER'S MANUAL

Model: 110-3PT-WP-309-1PC (5301807)
(110 Gallon 3-Point Carrier w/Pump, Coupler, Handgun, & 8-Row Boom)

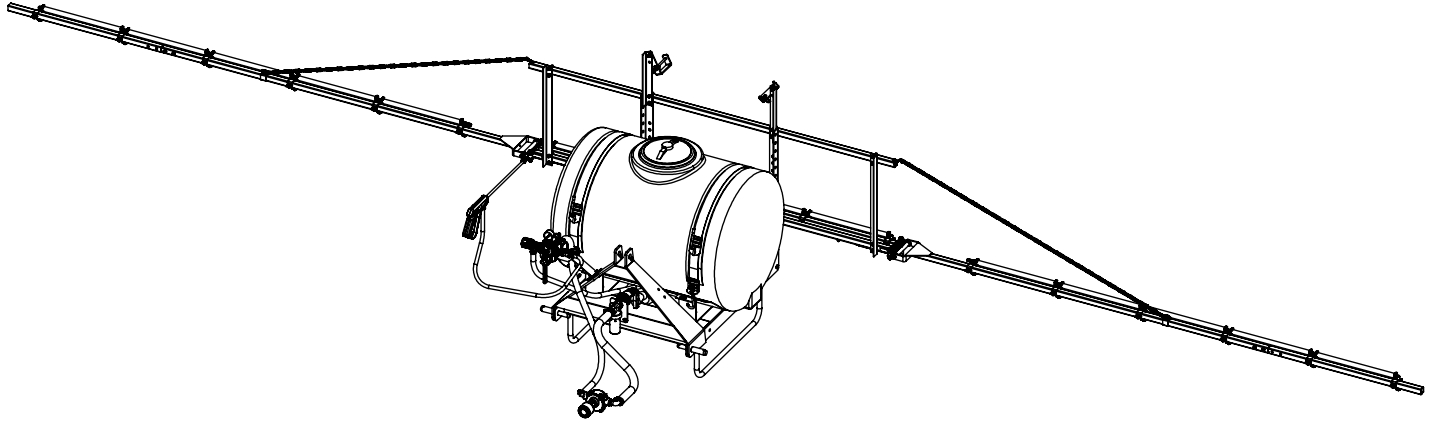

Assembly Instructions

BEFORE RETURNING THIS PRODUCT
FOR ANY REASON, PLEASE CALL

1-800-831-0027

IF YOU SHOULD HAVE A QUESTION OR
EXPERIENCE A PROBLEM WITH YOUR
FIMCO INDUSTRIES PRODUCT:

1-800-831-0027

BEFORE YOU CALL, PLEASE HAVE THE
FOLLOWING INFORMATION AVAILABLE:
SALES RECEIPT & MODEL NUMBER. IN MOST
CASES, A FIMCO INDUSTRIES EMPLOYEE CAN
RESOLVE THE PROBLEM OVER THE PHONE.

General Information

Thank you for purchasing this product. The purpose of this manual is to assist you in operating and maintaining your 3-Point sprayer. Please read it carefully, as it furnishes information which will help you achieve years of trouble-free operation.

Warranty/Parts/Service

Products are warranted for one year from date of purchase against manufacturer or workmanship defects.

Commercial users have a 90 day warranty.

Your authorized dealer is the best source of replacement parts and service. To obtain prompt, efficient service, always remember to give the following information...

- Correct Part Description and/or part number.
- Model number/Serial number of your sprayer.

Part descriptions and part numbers can be obtained from the illustrated parts list section(s) of this manual.

Whenever you need parts or repair service, contact your distributor/dealer first. For warranty work, always take your original sales slip, or other evidence of purchase date, to your distributor/dealer.

1. Install the tee valve sub-assembly to the 3 point carrier valve mount, and position as shown in the exploded view.
2. Slip the $\frac{1}{2}$ " bypass hose (from the relief valve) over the fitting on the bottom of the tank. Slide the hose clamp to the end of the hose and secure.
3. Find the 1" x 36" pump feeder hose. Using a good quality thread sealant, carefully thread the 1" fitting into the strainer and the $\frac{3}{4}$ " fitting into the inlet side of the pump. Slip the hose all the way onto the fittings and secure with the hose clamps.
4. Attach the $\frac{3}{4}$ " hose coming off the valve assembly to the output side of the pump by threading the $\frac{3}{4}$ " fitting into the pump and securing with the hose clamp. Remember to use sealant.
5. The roller pump is included with the assembly. Attach the adapter, the torque chain and S-hook to the pump as needed. It is intended for this pump to be mounted directly to the tractor PTO. The torque chain needs to be secured to the tractor to keep the pump from spinning.
6. Wrap the handgun hose around the hose hangers which are attached to the tank straps.
7. Using sealant thread the gauge into the top of the tee valve assembly.
8. Mount the upright angles to the inside of the mounts on the 3-point carrier using the supplied $\frac{1}{2}$ " bolts and nuts. Attach the backrack to the upright angles using the square U-bolts and nuts. Note: the backrack can be mounted in either a high or low position and the uprights can be adjusted for desired height. Attach the U-brackets as shown.
9. Loosen the eye bolts and remove the 7" hinge bolts. Line up the outer booms and reassemble the hinge bolt through the outer boom yoke, the hinge casting and the spring connector. Tighten the eye bolt until the spring is at the desired tension. Lock the eye bolt in place with the inner whiz flange locknut. Bolt on the boom extensions using the $\frac{3}{8}$ " X 1-3/4" bolts and hex lock nuts.



www.fimcoindustries.com

1000 FIMCO Lane, P.O. Box 1700, North Sioux City, SD 57049
Toll Free Phone: 800-831-0027 : Toll Free Fax: 800-494-0440
Form No. 1668 [5008064 (03/13)] Printed in the U.S.A.

Assembly Instructions (continued)

10. Hook an end of each boom chain on an "S" hook attached to the top bar tube. Slip a slide clamp onto each outer boom. Place the other end of the boom chain between the ears of the slide clamp and secure with a 3/8" X 1" flange screw. Level the outer booms by moving the slide clamps in or out as needed. Tighten the bolts in the slide clamps to hold the clamps in place.

11. Attach the appropriate hose assemblies onto each of the three boom sections. The center section has five nozzles, with "L" connectors on each end.

12. Join the designated feeder hose from the tee valve sub-assembly to each boom section and secure in place with hose clamps.

Tip Selection

Important note:

The tips supplied as standard with this boom assembly are number AIXR11003VP tips. when you refer to the rate charts found in this owners manual, these rates are based on water. Please read this tip selection section carefully before attempting to operate your boom assembly

The selection of proper tips for the boom is determined by the gallon per acre (GPA) requirement which is specified on the chemical label. The following characteristics also have a determining factor and must be considered:

1. Speed of spraying (MPH)
2. Boom nozzle spacing (specified in inches)
3. Solution weight and conversion factor (CF)
4. Gallons of solution to be sprayed per acre
5. Spraying pressure

Useful Formulas:

GPM - Gallons Per Minute

GPA - Gallons Per Acre

MPH - Miles Per Hour

Calibration

Chemical labels may show application rates in gallons per acre, gallons per 1000 square feet, or gallons per 100 square feet. You will note that the tip chart shows all 3 of these rating systems.

Once you know how much you are going to spray, then determine (from the tip chart) the spraying pressure (PSI), and the spraying speed (MPH).

Determining the proper speed of the pulling vehicle can be done by marking off 100, 200, & 300 feet. The speed chart indicates the number of seconds it takes to travel the distances. Set the throttle and with a running start, travel the distances. Adjust the throttle until you travel the distances in the number of seconds indicated by the speed chart. Once you have reached the throttle setting needed, mark the throttle location so you can stop and go again, returning to the same speed.

Add water and proper amount of chemical to the tank and drive to the starting place for spraying.

Suggested Minimum Spray Heights

Nozzle Type	Nozzle Height			
	Spray Angle	20" Spacing	30" Spacing	40" Spacing
TeeJet (Flat Spray)	65°	22"-24"	33"-35"	NR*
TeeJet (XR TeeJet)	80°	17"-19"	26"-28"	NR*
TeeJet (XR TeeJet)	110°	12"-14"	16"-18"	NR*
FloodJet	120°	***	***	***

* Not Recommended

*** Wide angle spray tip is influenced by nozzle orientation
The critical factor is to achieve a double spray pattern overlap.

Speed Chart			
Speed in M.P.H. (Miles per Hour)	Time Required in seconds to travel a distance of		
	100 Ft.	200 Ft.	300 Ft.
1.0	68 sec.	136 sec.	205 sec.
2.0	34	68	102
3.0	23	45	68
4.0	17	34	51
5.0	14	27	41
6.0	11	23	34
7.0	9.7	19	29
8.0	8.5	17	26
9.0	7.6	15	23
10.0	6.8	14	20

Spraying Solutions Other Than Water

Since all the tabulations are based on spraying water, which weighs 8.34 lbs per USA gallon, conversion factors must be used when spraying solutions which are heavier or lighter than water. To determine the proper size nozzle for the solution to be sprayed, first multiply the desired GPM or GPA of solution by the rate conversion factor. Then use the new converted GPM or GPA rate to select the proper size nozzle.

Example: Desired application rate is 20 GPA of 28% Nitrogen. Determine the correct nozzle size as follows:

GPA (Solution) x Conversion Factor = GPA

20 GPA (28%) x 1.13 = 22.6 GPA (Water)

The applicator should choose a nozzle size that will supply 22.6 GPA of water at the desired pressure.

Weight of Solution	Specific Gravity	Conversion Factors
7.0 lbs per gallon	.84	.92
8.0 lbs per gallon	.96	.98
8.834 lbs per gallon (Water)	1.00	1.00
9.0 lbs per gallon	1.08	1.04
10.0 lbs per gallon	1.20	1.10
10.65 lbs per gallon (28% Nitrogen)	1.28	1.13
11.0 lbs per gallon	1.32	1.15
12.0 lbs per gallon	1.44	1.20
14.0 lbs per gallon	1.68	1.30

Miscellaneous Conversion Factors

One Acre = 43,560 square feet = 0.405 Hectare

One Hectare = 2.471 Acres

One Gallon Per Acre = 9.35 Liters Per Hectare

One Mile = 5280 Feet = 1610 Meters = 1.61 Kilometers

One Gallon = 128 Fluid Ounces = 8 Pints = 4 Quarts = 3.79

Liters = 0.83 Imperial Gallons

One Pound Per Square Inch = 0.069 bar. = 6.895 Kilo-Pascals

One Mile Per Hour = 1.609 Kilometers Per Hour

Higher pressure not only increases the flow rate of the nozzle, but it also influences the droplet size and the rate of orifice wear. As pressure is increased, the droplet size decreases and the rate of orifice wear is increased.

The values given in the tabulation section of this owners manual indicate the most commonly used pressure ranges for the associated spray tips.

Tank Care and Maintenance

Warning: Do not use the tank as a container for fuel oils, kerosene, gasoline, or any other petroleum distillate product. All polyolefins are softened and permeated by such products. In an enclosed area the vaporization of these materials from the outside surface of the tank could create a dangerous condition.

The tank should not be used as a pressure vessel nor used with chemicals or solutions having a weight of more than 12 pounds per gallon.

Store the tank in a dry dark place when not in use. Storage out of sunlight will prolong the life of the trailer.

Do not drop, strike, or kick the tank, especially at low temperatures. Tanks become brittle and are subject to cracking at temperature below 20° Fahrenheit.

Always flush the tank with water and a neutralizing agent (such as 'Nutra-Sol') at the end of each use, to prevent contamination of solutions.

Information About The Sprayer

Roller pumps are positive displacement pumps, which means that the entire solution being pumped must go somewhere or the pump will break. In this roller pumping system, solution is drawn from the tank, and forced to a planned source, such as boom nozzles, or handgun. The pressure is controlled by a pressure relief valve, which is a spring-loaded device that controls the amount of fluid bypassed (or recirculated) to the tank. The gray handle is to be tightened to increase pressure, and loosened to decrease pressure.

The 'Tee-Valve' is the on/off control which allows the operator to manually control the solution going to the boom.

After Spraying

After use, fill the sprayer tank part way with water. Start the sprayer, and allow the clear water to be pumped through the plumbing system and out through the spray nozzles. Refill the tank about half full with plain water and use FIMCO Tank Neutralizer and Cleaner, and repeat cleaning instructions above. Flush the entire sprayer with the neutralizing/cleaning agent, then flush out one more time with plain water. Follow the chemical manufacturer's disposal instructions of all wash or rinsing water. For the boom, (if applicable) remove the tips and screens from the nozzle assemblies. Wash these items out thoroughly. Blow the orifice clean and dry. If the orifice remains clogged, clean it with a fine bristle (NOT WIRE) brush, or with a toothpick. Do not damage the orifice. Water rinse and dry the tips before storing.

WARNING: Some chemicals will damage the pump valves if allowed to soak untreated for a length of time! ALWAYS flush the pump as instructed after each use.

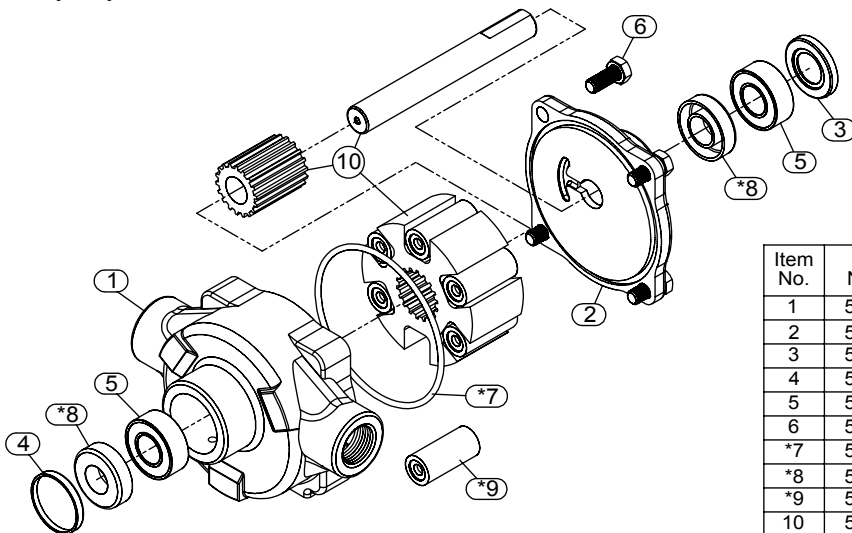

Testing the Sprayer

Attach the sprayer to the tractor 3 point hitch. Mount the pump to the PTO and affix the torque chain.

Open the tank lid and be sure the tank is clean and free of foreign material. Fill the tank about 1/2 full with plain water.

NOTE:

It is VERY important for you to test your sprayer with plain water before actual spraying is attempted. This will enable you to check the sprayer for leaks, without the possibility of losing any expensive chemicals.

Before starting, open the suction line valve (located underneath the carrier frame), turn the relief valve handle out to lower the line pressure. This will help prime the pump.

CAUTION: Always be sure that the water (or solution) has reached the pump before starting your sprayer. If the pump is allowed to run dry, serious damage to the pump will result.

Always have the pressure line open to the tips so that the air which may be trapped in the line will be forced (or purged) out.

Start the tractor PTO. Check the entire system for leaks. Once the pump is primed, the pressure may be increased by turning the handle of the pressure relief valve in. Keep the pressure line open to the tips when setting the pressure. Set the pressure and then lock the relief valve handle in place. Shut off the direct-valve and check for leaks again. Pressure will increase when the pressure line valve is closed and then return to the preset pressure when the valve is opened again.

During the testing period, be sure to observe the spray pattern given by the spray nozzles. If there is any pattern distortion, it will be necessary to remove and clean the affected tips.

Caution: Never use a metal object or other sharp item for cleaning a nozzle tip. It is better to use a nozzle brush (NOT wire brush) or compressed air for tip cleaning.



Cast Iron 6-Roller Pump Assembly #5271706 (Hypro Part #6500C)

* = Only available in Spare Parts Kit #7771795

Item No.	Part Number	Mfg Part Number	Qty	Description
1	5002274	0100-6600C	1	Body w/Seal (Cast Iron)
2	5017146	0200-6600C	1	End Plate (Cast Iron)
3	5017480	2300-0023	1	Shaft Bearing Cover
4	5017481	2300-0021	1	Bearing Cover
5	5031025	99502-H	2	Ball Bearing (Sealed)
6	5034038	2210-0004	4	H.H.C.S. 5/16"-18nc x 3/4" Long
*7	5072056	1720-0008	1	O-Ring Gasket
*8	5110052	2107-0002	2	Seal (Viton)
*9	5112030	1005-0004	6	Super Roller (Standard)
10	5172038	0300-6600C	1	Rotor/Shaft Assembly

PISTON TYPE PRESSURE RELIEF/REGULATING VALVES

Bypasses excess liquid. Adjustable to maintain control of line pressure at any pressure within the valve operating range. Selected pressure setting firmly held in place by locknut. Extra large passages to handle large flows.

- Polypropylene with stainless steel spring
- Excellent chemical resistance
- EPDM O-Rings
- For pressure to 150 p.s.i.
- 1/4" port for pressure gauge
- Choice of 1/2" or 3/4" NPT (M) inlet & (F) outlet connections

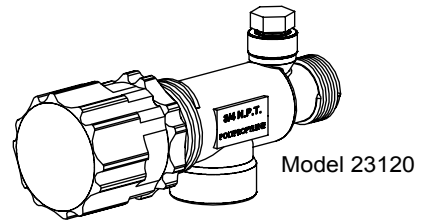
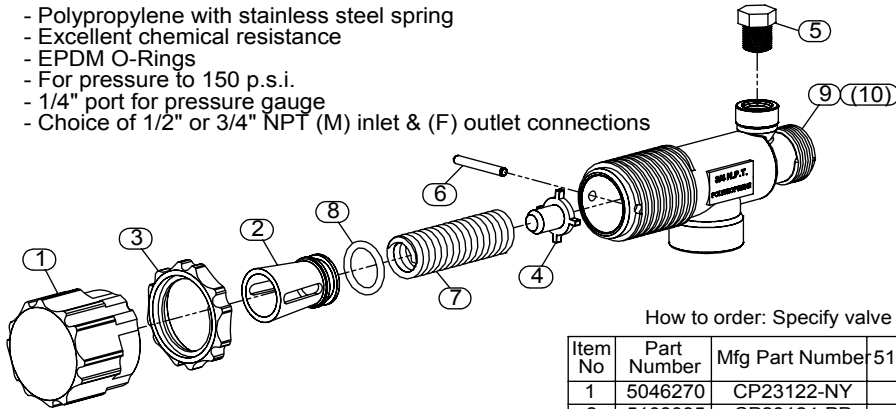

How to order: Specify valve number (Example: 23120-1/2-PP Polypropylene)

Item No	Part Number	Mfg Part Number	5143199/Qty	5143200/Qty	Description
1	5046270	CP23122-NY	1	1	Adjusting Cap, Nylon (Gray)
2	5108095	CP23124-PP	1	1	Spring Retainer
3	5110266	CP23123-PP	1	1	Lock Ring
4	5115078	CP23125-PP	1	1	Guide Seat
5	**	F14	1	1	Pipe Plug, 1/4" MNPT
6	**	CP23126-302SS	1	1	Retaining Pin
7	**	CP23127-302SS	1	1	Spring
8	**	CP7717-15-EPR	1	1	O-Ring, EPDM Rubber
9	---	CP23121-PP	1	-	Poly Body (3/4" NPT)
10	---	CP23128-PP	-	1	Poly Body (1/2" NPT)

FIMCO Number	Mfg Part Number	Description
5143199	23120-3/4-PP	3/4" Poly Valve
5143200	23120-1/2-PP	1/2" Poly Valve
5168717	PK-AB23120-KIT	Repair Kit, Items Marked **

Winter Storage

Drain all water out of your sprayer, paying special attention to the pump, handgun, and valve(s). These items are especially prone to damage from chemicals and freezing weather.

The sprayer should be winterized before storage by pumping a solution of RV antifreeze through the entire plumbing system. This antifreeze solution should remain in the plumbing system during the winter months. When spring time comes and you are preparing your sprayer for the spray season, rinse the entire plumbing system out, clearing the lines of the antifreeze solution. Proper care and maintenance will prolong the life of your sprayer.

TeeValve Control Valve Model: AA17L (Fimco Part #5143295)

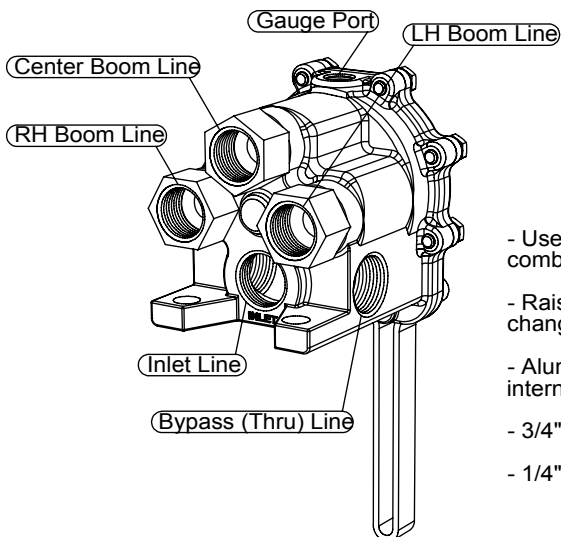

Model AA17L, used for selective control of 3-section boom sprayers at pressures up to 300 psi.

- Use to open any of three boom sections lines in any desired combination.
- Raise lever to open, lower lever to close the valve without changing the indexed position.
- Aluminum construction with stainless steel and plastic internal parts for maximum corrosion resistance.
- 3/4" NPT Inlet/Outlet, 3 boom outlet & accessory outlet.
- 1/4" NPT Gauge Port.

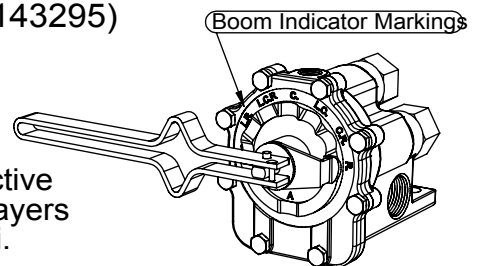

RH boom is 'selected'

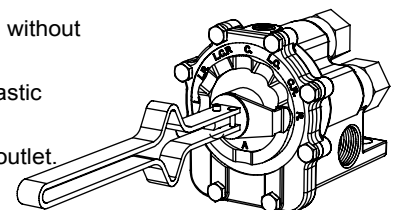

RH boom is 'activated'

Exploded View:
 110-3PT-WP-309-1PC
 (5301807)

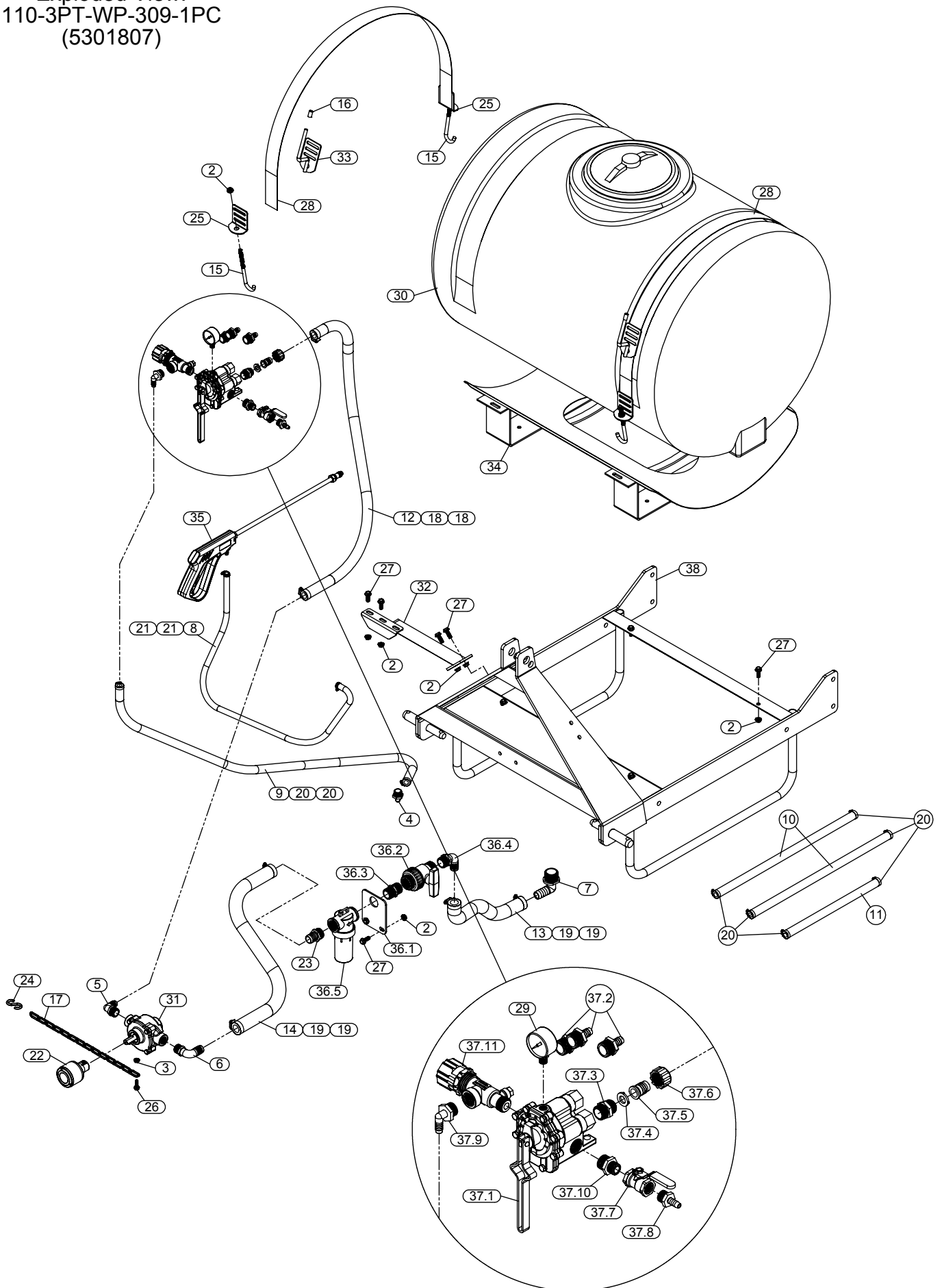

Parts List: 110-3PT-WP-309-1PC (5301807)

Item No	Part Number	Qty.	Description
1	257-8	1	(8-Row) Boom Assembly
2	5006259	14	3/8"-16 Hex Whiz (Flange) Locknut
3	5006307	1	5/16"-18 Hex Whiz (Flange) Locknut
4	5010207	1	Poly Elbow, 3/4" MNPT x 1/2" HB
5	5010209	1	Poly Elbow, 3/4" MNPT x 3/4" HB
6	5010210	1	Poly Elbow, 3/4" MNPT x 1" HB
7	5010215	1	Poly Elbow, 1 1/4" MNPT x 1" HB
8	5020099	1	Hose, 3/8"-2 Brd. x 25 Ft.
9	5020122	1	Hose, 1/2"-1 Brd. x 48"
10	5020164	2	Hose, 1/2"-1 Brd. x 11 Ft.
11	5020167	1	Hose, 1/2"-1 Brd. x 90"
12	5020179	1	Hose, 3/4"-2 Brd. x 6 Ft.
13	5020315	1	Hose, 1"-2 Brd. x 24"
14	5020338	1	Hose, 1"-2 Brd. x 36"
15	5034173	4	3/8" x 5 1/2" J-Hook Bolt
16	5046085	2	Cap
17	5049017	1	Torque Chain, 24"
18	5051024	2	Hose Clamp, 3/4"
19	5051025	4	Hose Clamp, 1"
20	5051114	8	Hose Clamp (3/8"-1/2")
21	5051144	2	Hose Clamp (3/8")
22	5057145	1	Quick Coupler (5/8")
23	5067118	1	Poly Fitting, 1" MNPT x 1" HB
24	5082006	1	"S" Hook
25	5108041	4	Tank Strap Buckle, Bent
26	5117300	1	5/16"-18 x 1" Flange Whiz Lock Screw
27	5117307	10	3/8"-16 x 1" Whiz (Flange) Lockscrew

Item No	Part Number	Qty.	Description
28	5133101	2	Nylon Strap (2" x 72")
29	5167005	1	Gauge, 0-400 p.s.i. (Dry)
30	5169003	1	110 Gallon Tank (30" Dia.)
31	5271706	1	6-Roller Pump Assembly (6500C)
32	5271771	1	Valve Mount
33	5271863	2	Hose Hanger Weldment
34	5273904	1	Saddle Weldment (30"-110 Gallon)
35	5273959	1	Deluxe Pistol-Grip Handgun w/X-26 Tip
36	5274765	1	Strainer Sub-Assembly
36.1	5038247	1	Strainer Bracket
36.2	5143207	1	1" Single Union Ball Valve
36.3	5011141	1	Poly Close Nipple, 1" MNPT
36.4	5010213	1	Poly Elbow, 1" MNPT x 1" HB
36.5	5116441	1	1" Nylon Strainer (Black, 40 Mesh)
37	5275731	1	TeeValve Plumbing Assembly
37.1	5143295	1	TeeValve Assembly (AA-17L)
37.2	5067125	3	Poly Fitting, 3/4" MNPT x 1/2" HB
37.3	5005196	1	Poly Adapter, 3/4" MNPT x 3/4" MGHT
37.4	5016066	1	Garden Hose Washer
37.5	5149037	1	Poly Swivel, 3/4" Flat Seat Hose Barb
37.6	5006209	1	Poly Knurled Swivel Nut, 3/4" FGHT
37.7	5143197	1	1/2" T-800 Brass Ball Valve
37.8	5067130	1	Poly Fitting, 1/2" MNPT x 3/8" HB
37.9	5010207	1	Poly Elbow, 3/4" MNPT x 1/2" HB
37.10	5011147	1	Poly Reducing Nipple, 3/4" MNPT x 1/2" MNPT
37.11	5143199	1	Pressure Relief Valve, 3/4"
38	5275776	1	27-D (3-Point) Frame Weldment (Red)

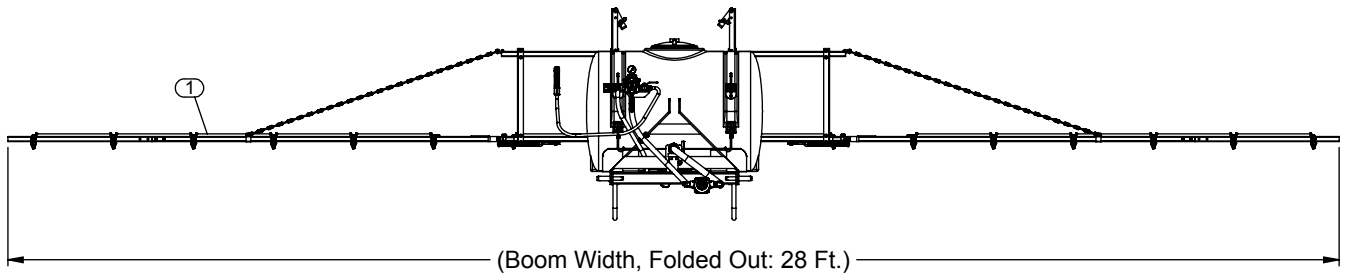

Torque Chain Attachment to a Roller Pump

Strap/Buckle Detail
Strap Attachment to a "Bent" Buckle

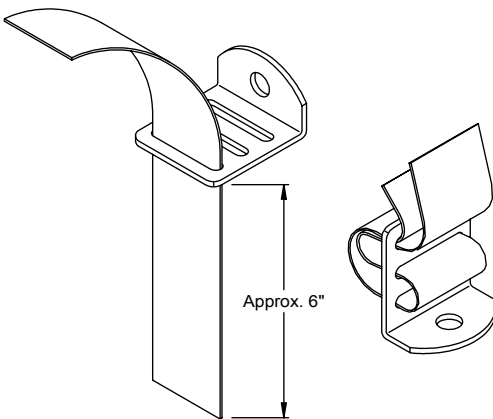

The nylon straps are to be inserted in and out of the slots in the buckle, as shown. Be sure the straps are snug before tightening the hook bolts. In most cases, it will be necessary to re-tighten the straps after filling the tank with liquid.

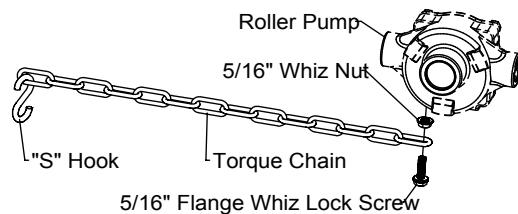

A torque chain, "S" hook, nut, and bolt are included in this assembly, to secure your pump during operation.

1. Attach one end of the torque chain over the threaded stem of the bolt.
2. Thread the whiz nut onto the bolt. Hand-tighten.
3. Thread the bolt, chain, & nut 'pre-assembly' into the threaded hole on the underside of the pump. Tighten sufficiently.
4. Affix the "S" Hook to your frame (or hitch). Wrap the chain around the frame or hitch, and 'S-Hook' it in place. Make sure this connection is very secure! Not having a good, tight connection may result in the pump spinning on your PTO shaft, and damaging some components of your sprayer.

*** Insure that this connection point will not allow the roller pump to spin on the PTO shaft ***

Model: 257-8 (8-Row) Boom Assembly

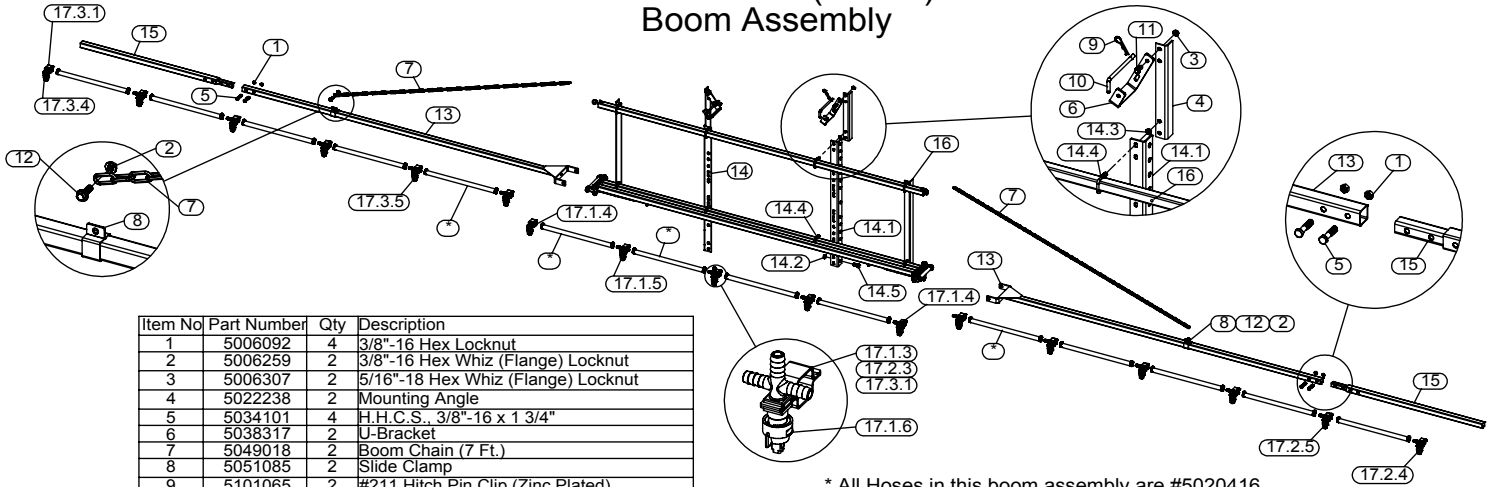

Item No	Part Number	Qty	Description
1	5006092	4	3/8"-16 Hex Locknut
2	5006259	2	3/8"-16 Hex Whiz (Flange) Locknut
3	5006307	2	5/16"-18 Hex Whiz (Flange) Locknut
4	5022238	2	Mounting Angle
5	5034101	4	H.H.C.S., 3/8"-16 x 1 3/4"
6	5038317	2	U-Bracket
7	5049018	2	Boom Chain (7 Ft.)
8	5051085	2	Slide Clamp
9	5101065	2	#211 Hitch Pin Clip (Zinc Plated)
10	5101231	2	Pin
11	5117300	2	5/16"-18 x 1" Flange Whiz Lock Screw
12	5117307	2	3/8"-16 x 1" Whiz (Flange) Lockscrew
13	5273313	2	End Boom Weldment
14	5275256	2	Upright Assembly
14.1	5022255	1	Boom Upright Angle
14.2	5006337	2	1/2"-13 Hex Whiz (Flange) Locknut
14.3	5006307	4	5/16"-18 Hex Whiz (Flange) Locknut
14.4	5034159	2	Square U-Bolt, 5/16" x 1 5/16" x 1 7/8"
14.5	5034019	2	H.H.C.S., 1/2"-13nc x 1 1/4" Long
15	5275736	2	Boom Extension (for 8-Row)
16	5277359	1	257 Boom Center Section Assembly
17	5277894	1	257-8 Nozzle Harness (Complete)
17.1	5277761	1	Center Nozzle Harness Assembly (257-8)
17.1.1	5051114	8	Hose Clamp (3/8"-1/2")
17.1.2	5020416	4	Hose, 1/2"-1 Brd. x 19 3/8"
17.1.3	5272165	5	Vari-Quick Clamp (1 1/4" Sq. Tube)

* All Hoses in this boom assembly are #5020416

Item No	Part Number	Qty	Description
17.1.4	5277707	2	"ELL" Nozzle Assembly (3/8")
17.1.5	5277708	2	"TEE" Nozzle Assembly (3/8")
17.1.6	5277709	1	"CROSS" Nozzle Assembly (3/8")
17.2	5277806	1	RH Nozzle Harness Assembly (257-8)
17.2.1	5051114	10	Hose Clamp (3/8"-1/2")
17.2.2	5020416	5	Hose, 1/2"-1 Brd. x 19 3/8"
17.2.3	5272165	6	Vari-Quick Clamp (1 1/4" Sq. Tube)
17.2.4	5277707	1	"ELL" Nozzle Assembly (3/8")
17.2.5	5277708	5	"TEE" Nozzle Assembly (3/8")
17.3	5277812	1	LH Nozzle Harness Assembly (257-8)
17.3.1	5272165	6	Vari-Quick Clamp (1 1/4" Sq. Tube)
17.3.2	5020416	5	Hose, 1/2"-1 Brd. x 19 3/8"
17.3.3	5051114	10	Hose Clamp (3/8"-1/2")
17.3.4	5277707	1	"ELL" Nozzle Assembly (3/8")
17.3.5	5277708	5	"TEE" Nozzle Assembly (3/8")

5277359 257-8 Boom Center Section Exploded View & Parts List

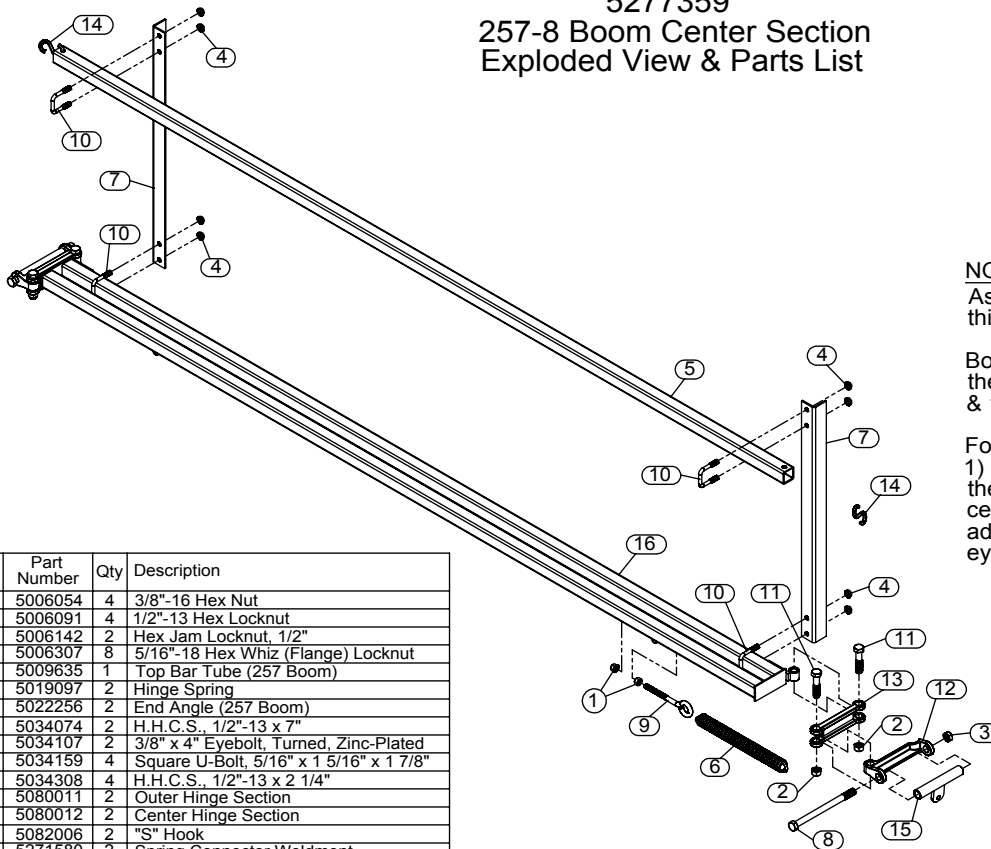

Item No.	Part Number	Qty	Description
1	5006054	4	3/8"-16 Hex Nut
2	5006091	4	1/2"-13 Hex Locknut
3	5006142	2	Hex Jam Locknut, 1/2"
4	5006307	8	5/16"-18 Hex Whiz (Flange) Locknut
5	5009635	1	Top Bar Tube (257 Boom)
6	5019097	2	Hinge Spring
7	5022256	2	End Angle (257 Boom)
8	5034074	2	H.H.C.S., 1/2"-13 x 7"
9	5034107	2	3/8" x 4" Eyebolt, Turned, Zinc-Plated
10	5034159	4	Square U-Bolt, 5/16" x 1 5/16" x 1 7/8"
11	5034308	4	H.H.C.S., 1/2"-13 x 2 1/4"
12	5080011	2	Outer Hinge Section
13	5080012	2	Center Hinge Section
14	5082006	2	"S" Hook
15	5271580	2	Spring Connector Weldment
16	5273315	1	Center Boom Weldment

NOTES:

Assembly of opposite end is similar to this end!

Bolt (Item 8) goes through the yoke on the outer boom(s), then through Item 12 & 15, followed with jam locknut (Item 3).

For the eyebolt, thread the 1st nut (Item 1) onto the eyebolt, then feed it through the hole in the angle under the lower center section. Use the next nut for adjusting and the first nut for locking the eyebolt into position.

Center "Back-Rack" Mounted
in the "High" Position

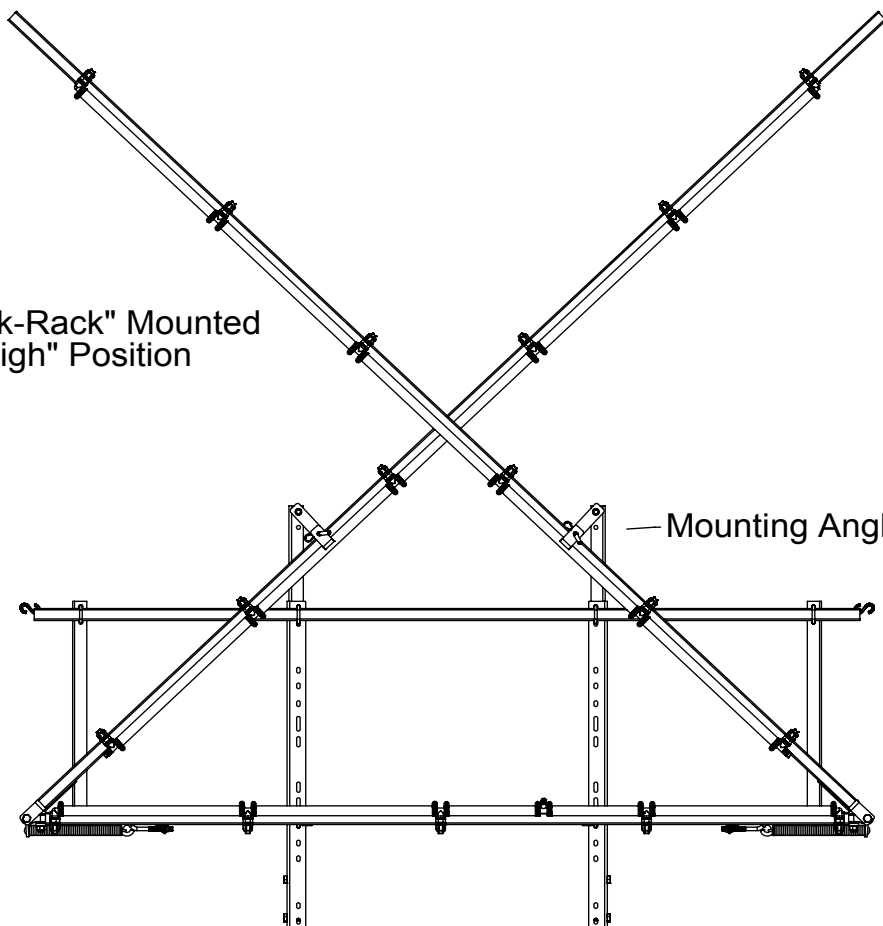

Mounting Angles ARE used

Center "Back-Rack" Mounted
in the "Low" Position

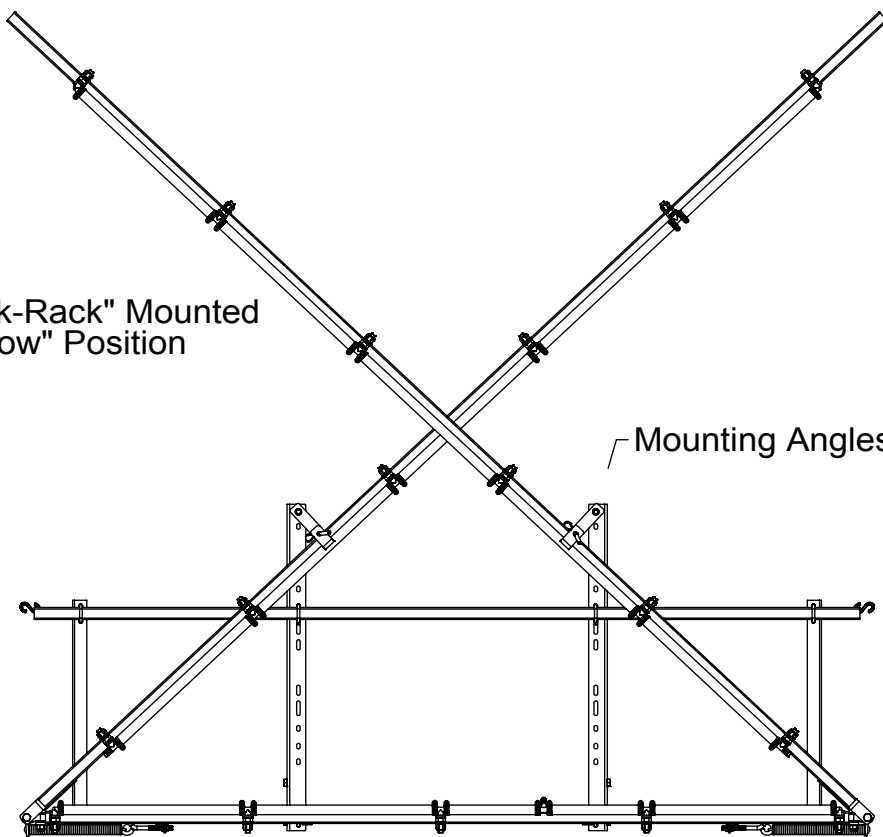

Mounting Angles are NOT used