

OWNER'S MANUAL

Model: 200-3PT-1PC (5300439)

(200 Gallon 3-Point Sprayer w/8-Row Boom)

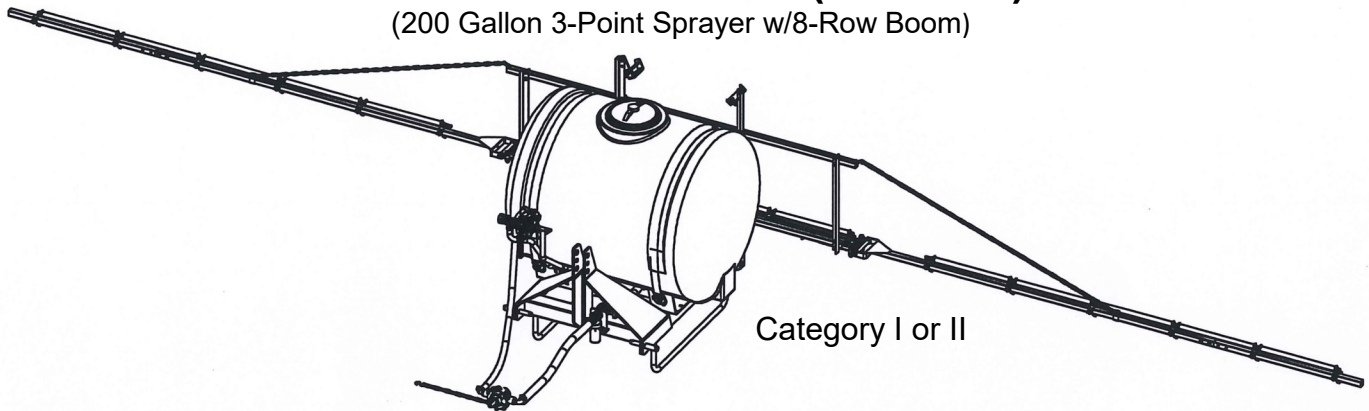

Assembly Instructions

1. Install the tee valve sub-assembly to the 3-point carrier valve mount and position as shown in the exploded view.
2. Slip the 1/2" bypass hose (from the relief valve) over the fitting on the bottom of the tank. Slide the hose clamp to the end of the hose and secure.

BEFORE RETURNING THIS PRODUCT FOR ANY REASON, PLEASE CALL

1-800-831-0027

IF YOU SHOULD HAVE A QUESTION OR EXPERIENCE A PROBLEM WITH YOUR FIMCO INDUSTRIES PRODUCT:

1-800-831-0027

BEFORE YOU CALL, PLEASE HAVE THE FOLLOWING INFORMATION AVAILABLE: SALES RECEIPT & MODEL NUMBER. IN MOST CASES, A FIMCO INDUSTRIES EMPLOYEE CAN RESOLVE THE PROBLEM OVER THE PHONE.

General Information

Thank you for purchasing this product. The purpose of this manual is to assist you in operating and maintaining your 3-Point Sprayer.



WARNING: To reduce the risk of injury, the user must read and understand the operator's manual before using this product.



WARNING: Cancer and Reproductive Harm
www.P65Warnings.ca.gov

Retain a copy of your receipt for your unit, as it will be required to validate any warranty service
Products are warranted against manufacturer or workmanship defects for one year from date of purchase for home owner usage and 90 days for commercial usage.

For technical assistance, visit our website @ www.fimcoindustries.com or call: **TOLL FREE @ 1-800-831-0027** Our Technical Support Representatives will be happy to help you. To obtain prompt, efficient service, always remember to give the following information...

- Correct Part Description and/or part number
- Model #/Serial # of your sprayer

Part descriptions and numbers can be obtained from the illustrated parts list section(s) of this manual.

3. Find the 1" x 36" pump feeder hose. Using a good quality thread sealant, carefully thread the 1" fitting into the strainer and the 3/4" fitting into the inlet side of the pump. Slip the hose all the way onto the fittings and secure with the hose clamps.
4. Attach the 3/4" hose coming off the valve assembly to the output side of the pump by threading the 3/4" fitting into the pump and securing with the hose clamp. Remember to use sealant.
5. The roller pump is NOT included with the assembly. Attach the adapter, the torque chain and S-hook to a pump as needed. It is intended for your pump to be mounted directly to the tractor PTO. The torque chain needs to be secured to the tractor to keep your pump from spinning.
6. Using sealant thread the gauge into the top of the tee valve assembly.
7. Mount the upright angles to the inside of the mounts on the 3-point carrier using the supplied 1/2" bolts and nuts. Attach the backrack to the upright angles using the square U-bolts and nuts. Note: the backrack can be mounted in either a high or low position and the uprights can be adjusted for desired height. Attach the U-brackets as shown.
8. Loosen the eye bolts and remove the 7" hinge bolts. Line up the outer booms and reassemble the hinge bolt through the outer boom yoke, the hinge casting and the spring connector. Tighten the eye bolt until the spring is at the desired tension. Lock the eye bolt in place with the inner whiz flange locknut. Bolt on the boom extensions using the 3/8" x 1-3/4" bolts and hex lock nuts.
9. Hook an end of each boom chain on an "S" hook attached to the top bar tube. Slip a slide clamp onto each outer boom. Place the other end of the boom chain between the ears of the slide clamp and secure with a 3/8" x 1" flange screw. Level the outer booms by moving the slide clamps in or out as needed. Tighten the bolts in the slide clamps to hold the clamps in place.
10. Attach the appropriate hose assemblies onto each of the three boom sections. The center section has five nozzles with "L" connectors on each end.
11. Join the designated feeder hose from the tee valve sub-assembly to each boom section and secure in place with hose clamps.



www.fimcoindustries.com

1000 FIMCO Lane, P.O. Box 1700, North Sioux City, SD 57049
Toll Free Phone: 800-831-0027 : Toll Free Fax: 800-494-0440
[5008153 (12/18)]

Information About the Sprayer

Roller pumps are positive displacement pumps, which means that the entire solution being pumped must go somewhere or the pump will break. In this roller pumping system, solution is drawn from the tank and forced to a planned source, such as boom nozzles or hand-gun. The pressure is controlled by a pressure relief valve, which is a spring-loaded device that controls the amount of fluid bypassed (recirculated) to the tank. The gray handle is to be tightened to increase pressure and loosened to decrease pressure.

The 'directo-valve' is the on/off control which allows the operator to manually control the solution going to the boom.

IMPORTANT: Remove tank lid and be sure the tank is clean and free of any foreign material. Rinse tank out of any tank residue before filling with water to test.

Tip Information

Important note about tips: When you refer to the rate charts found in this owners manual, these rates are based on water. Please read this tip selection section carefully before attempting to operate your boom assembly.

The selection of proper tips for the boom is determined by the gallon per acre (GPA) requirement which is specified on the chemical label. The following characteristics also have a determining factor and must be considered.

1. Speed of spraying (MPH).
2. Boom nozzle spacing (specified in inches).
3. Solution weight and conversion factor (CF)
4. Gallons of solution to be sprayed per acre.
5. Spraying pressure.

Useful Formulas:

GPM = Gallons Per Minute

GPA = Gallons Per Acre

MPH = Miles Per Hour

Calibration

Chemical labels may show application rates in gallons per acre, gallons per 1000 square feet or gallons per 100 square feet. You will note that the tip chart (later in this manual) shows 2 of these rating systems. Once you know how much you are going to spray, then determine (from the tip chart) the spraying pressure (PSI), and the spraying speed (MPH).

Determining the proper speed of the pulling vehicle can be done by marking off 100, 200 & 300 feet. The speed chart indicates the number of seconds it takes to travel the distances. Set the throttle and with a running start, travel the distances. Adjust the throttle until you travel the distances in the number of seconds indicated by the speed chart. Once you have reached the throttle setting needed, mark the throttle location so you can stop and go again, returning to the same speed.

Add water and proper amount of chemical to the tank and drive to the starting place for spraying

Suggested Minimum Spray Heights				
Nozzle Type	Nozzle Height			
	Spray Angle	20" Spacing	30" Spacing	40" Spacing
TeeJet (Flat Spray)	65°	22"-24"	33"-35"	NR*
TeeJet (XR TeeJet)	80°	17"-19"	26"-28"	NR*
TeeJet (XR TeeJet)	110°	12"-14"	16"-18"	NR*
FloodJet	120°	***	***	***

* Not Recommended

*** Wide Angle Spray Tip is influenced by nozzle orientation.

The critical factor is to achieve a double spray patten overlap.

Speed Chart			
Speed in M.P.H. (Miles Per Hour)	Time Required in seconds to travel a distance of		
	100 Ft.	200 Ft.	300 Ft.
1.0	68 sec.	136	205
2.0	34	68	102
3.0	23	45	68
4.0	17	34	51
5.0	14	27	41
6.0	11	23	34
7.0	9.7	19	29
8.0	8.5	17	26
9.0	7.6	15	23
10.0	6.8	14	20

Spray Tip Rate Chart (20" Spacing)									
Tip No.	Pressure (psi)	Capacity (GPM)	Gal. Per Acre - Based on Water						
			1 MPH	2 MPH	3 MPH	4 MPH	5 MPH	6 MPH	8 MPH
AIXR11003VP	15	.18	53.6	26.8	17.8	13.4	10.7	8.9	6.7
	20	.21	62.4	31.2	20.8	15.6	12.5	10.4	7.8
	30	.26	77.2	38.6	25.8	19.3	15.4	12.9	9.7
	40	.30	88.0	44.0	29.8	22.0	17.8	14.9	11.1
Tip No.	Pressure (psi)	Capacity (GPM)	Gal. Per 1000 Sq. Ft. - Based on Water						
			1 MPH	2 MPH	3 MPH	4 MPH	5 MPH	6 MPH	8 MPH
AIXR11003VP	15	.18		.61	.41	.31	.24		
	20	.21		.71	.48	.36	.29		
	30	.26		.88	.59	.44	.35		
	40	.30		1.0	.68	.51	.41		

Using the Boom Nozzles

Four things must be considered before spraying with the boom.

1. How much chemical must be mixed in the tank.
 2. Rate of spray (gallons per acre to be sprayed).
 3. What pressure (p.s.i.) will be used.
 4. Speed traveled (mph) while spraying.
- * Refer to the chemical label to determine your chemical mixture
 - * See the tip chart to determine the pressure to be used. The chart will also show the speed used when spraying.
 - * Start the pump and open the valve to the boom nozzles.
 - * Check the spray pattern. Usually you can see the coverage better on a solid concrete surface, such as a driveway.

Weight of Solution	Specific Gravity	Conversion Factors
7.0 lbs. per gallon	.84	.92
8.0 lbs. per gallon	.96	.98
8.345 lbs. per gallon (Water)	1.00	1.00
9.0 lbs. per gallon	1.08	1.04
10.0 lbs. per gallon	1.20	1.10
10.66 lbs. per gallon (28% Nitrogen)	1.28	1.13
11.0 lbs. per gallon	1.32	1.15
12.0 lbs. per gallon	1.44	1.20
14.0 lbs. per gallon	1.68	1.30

Spraying Solutions Other Than Water

Since all the tabulations are based on spraying water, which weighs 8.34 lbs. per USA gallon, conversion factors must be used when spraying solutions which are heavier or lighter than water. To determine the proper size nozzle for the solution to be sprayed, first multiply the desired GPM or GPA of solution by the rate conversion factor. Then use the new converted GPM or GPA rate to select the proper size nozzle.

Example: Desired application rate is 20 GPA of 28% Nitrogen.

Determine the correct nozzle size as follows:

GPA (Solution) x Conversion Factor = GPA

20 GPA (28%) x 1.13 = 22.6 GPA (Water)

The applicator should choose a nozzle size that will supply 22.6 GPA of water at the desired pressure.

Miscellaneous Conversion Factors

One Acre = 43,560 square feet = 0.405 Hectare

One Hectare = 2.471 Acres

One Gallon Per Acre = 9.35 Liters Per Hectare

One Mile = 5,280 Feet = 1,610 Meters = 1.61 Kilometers

One Gallon = 128 Fluid Ounces = 8 Pints = 4 Quarts = 3.79 Liters = 0.83 Imperial Gallons

One Pound Per Square Inch = 0.069 bar. = 6.895 Kilopascals

One Mile Per Hour = 1.609 Kilometers Per Hour

Higher pressure not only increases the flow rate of the nozzle, but it also influences the droplet size and the rate of orifice wear. As pressure is increased, the droplet size decreases and the rate of orifice wear is increased.

The values given in the tabulation section of this owners manual indicate the most commonly used pressure ranges for the associated spray tips.

Testing the Sprayer

Attach the sprayer to the tractor 3 point hitch. Mount the pump to the PTO and affix the torque chain.

NOTE: It is important for to test your sprayer with plain water before actual spraying is attempted. This will enable you to familiarize yourself and check for leaks without the possibility of losing any expensive chemicals.

Fill the tank about 1/2 full with plain water.

Before starting, open the suction line valve (located underneath the carrier frame), turn the relief valve handle out to lower the line pressure. This will help prime the pump.

CAUTION: Always be sure that the water (or solution) has reached the pump before starting your sprayer. If the pump is allowed to run dry, serious damage to the pump will result.

Always have the pressure line open to the tips so that the air which may be trapped in the line will be forced (or purged) out. Start the tractor PTO. Check the entire system for leaks. Once the pump is primed, the pressure may be increased by turning the handle of the pressure relief valve in. Keep the pressure line open to the tips when setting the pressure. Set the pressure and then lock the relief valve handle in place. Shut off the directo-valve and check for leaks again. Pressure will increase when the pressure line valve is closed and then return to the preset pressure when the valve is opened again.

During the testing period, be sure to observe the spray pattern given by the spray nozzles. If there is any pattern distortion, it will be necessary to remove and clean the affected tips.

Caution: Never use a metal object or other sharp item for cleaning a nozzle tip. It is better to use a nozzle brush (NOT wire brush) or compressed air for tip cleaning.

Conditions of weather and terrain must be considered when setting the sprayer. Do not spray on windy days. Protective clothing must be worn in some cases

Be sure to read the chemical label(s) before application!

Operation

The performance of any agricultural chemical depends upon the proper application.

Always fill the tank with a desired amount of water first and then add the chemical slowly, mixing as you pour the chemical into the tank. You may use the handgun to spraying into the solution in order to mix the chemical and water.

The tips supplied as standard with the sprayer can be used for a wide variety of spraying applications. Other tip sizes are available for different coverages. The speed and pressure charts shown indicate the rates can be changed considerably by changing speed and pressure. The pumping system draws solution from the tank through the strainer/filter and to the pump. The pump forces the solution under pressure to the boom nozzles.

Tank Care & Maintenance

Warning: Do not use the tank as a container for fuel oils, kerosene, gasoline or any other petroleum distillate product. All polyolefins are softened and permeated by such products. In an enclosed area the vaporization of these materials from the outside surface of the tank could create a dangerous condition.

The tank should not be used as a pressure vessel nor used with chemicals or solutions having a weight of more than 12 pounds per gallon.

Store the tank in a dry dark place when not in use. Storage out of sunlight will prolong the life of the tank.

Do not drop, strike or kick the tank, especially at low temperatures. Tanks become brittle and are subject to cracking at temperatures below 20° Fahrenheit.

Maintenance During/After Spraying

Periodically close the suction line valve and check the strainer and clean the screen.

Proper care and maintenance will prolong the life of your sprayer.

After use, fill the sprayer tank part way with water. Start the sprayer and allow the clear water to be pumped through the plumbing system and out through the spray nozzles. Refill the tank about half full with

plain water and use FIMCO Tank Neutralizer and Cleaner and repeat cleaning instructions above (If no tank cleaner is available, you may substitute dish soap for this step, about 1-2 oz. per gallon). Flush the entire sprayer with the neutralizing/cleaning agent, then flush out one more time with plain water. Follow the chemical manufacturer's disposal instructions of all wash or rinsing water. For the boom (if applicable) remove the tips and screens from the nozzle assemblies. Wash these items out thoroughly. Blow the orifice clean and dry. If the orifice remains clogged, clean it with a fine bristle (NOT WIRE) brush or with a toothpick. Do not damage the orifice. Water rinse and dry the tips before storing.

WARNING: Some chemicals will damage the pump valves if allowed to soak untreated for a length of time! ALWAYS flush the pump as instructed after each use. DO NOT allow chemicals to sit in the pump for extended times of idleness. Follow the chemical manufacturer's instructions on disposal of all waste water from the sprayer.

Winter Storage

Drain all water out of your sprayer, paying special attention to the pump, handgun and valve(s). These items are especially prone to damage from chemicals and freezing weather. The sprayer should be winterized before storage by pumping a solution of automotive antifreeze (containing a rust inhibitor) through the entire plumbing system. This antifreeze solution should remain in the plumbing system during the winter months. When spring time comes and you are preparing your sprayer for the spray season, rinse the entire plumbing system out, clearing the lines of the antifreeze solution. Proper care and maintenance will prolong the life of your sprayer.

Strap/Buckle Detail Strap Attachment to a "Bent" Buckle

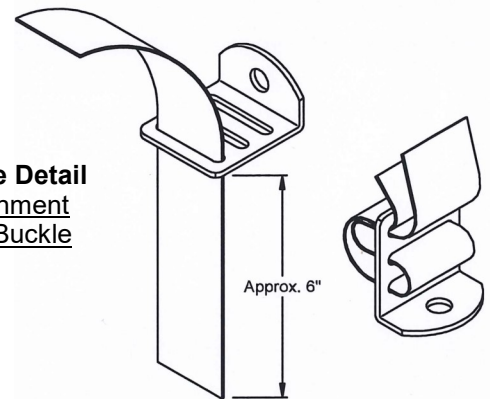

The nylon straps are to be inserted in and out of the slots in the buckle, as shown. Be sure the straps are snug before tightening the hook bolts. In most cases, it will be necessary to re-tighten the straps after filling the tank with liquid.

Torque Chain Attachment to a Roller Pump

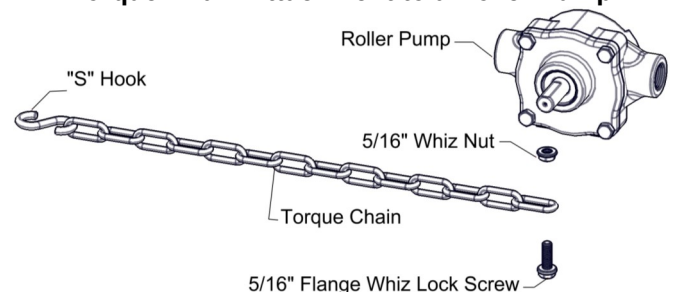

A torque chain, 'S' hook, nut and bolt are included in this assembly to secure your pump during operation.

1. Attach one end of the torque chain over the threaded stem of the bolt
2. Thread the whiz nut onto the bolt. Hand-tighten
3. Thread the bolt, chain and nut 'pre-assembly' into the threaded hole on the underside of the pump. Tighten sufficiently
4. Affix the 'S' Hook to your frame (or hitch). Wrap the chain around the frame or hitch and 'S-Hook' it in place. Make sure this connection is very secure! Not having a good, tight connection may result in the pump spinning on your PTO shaft and damaging some components of your sprayer

*** Insure that this connection point will not allow the roller pump to spin on the PTO shaft ***

Piston Type Pressure Relief/Regulating Valves

Bypasses excess fluid. Adjustable to maintain control of line pressure at any pressure within the valve operating range. Selected pressure setting firmly held in place by locknut. Extra large passages to handle large flows.

- Polypropylene with stainless steel spring
- Excellent chemical resistance
- EPDM O-Rings
- Fore pressure to 150 p.s.i.
- 1/4" port for pressure gauge
- Choice of 1/2" or 3/4" NPT (M) inlet & (F) outlet connections

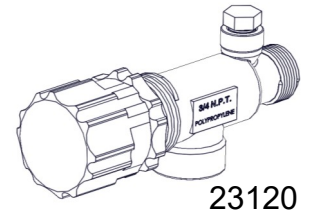
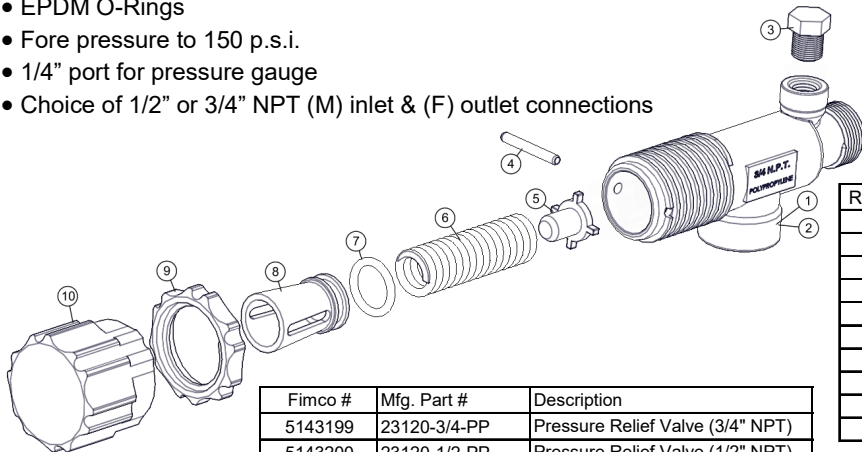

Ref. #	Fimco #	Mfg. Part #	Description
1	CP23121-PP	CP23121-PP	Poly Body (3/4" NPT)
2	CP23128-PP	CP23128-PP	Poly Body (1/2" NPT)
3	5102022	F14	Pipe Plug, 1/4" MNPT
4	**	CP23126-302SS	Retaining Pin
5	◆◆	CP23125-PP	Guide Seat
6	**	CP23127-302SS	Spring
7	**	CP7717-15-EPR	O-Ring, EPDM Rubber
8	◆◆	CP23124-PP	Spring Retainer
9	5110266	CP23123-PP	Lock Ring
10	5046270	CP23122-NY	Adjusting Cap, Nylon (Gray)

Fimco #	Mfg. Part #	Description
5143199	23120-3/4-PP	Pressure Relief Valve (3/4" NPT)
5143200	23120-1/2-PP	Pressure Relief Valve (1/2" NPT)
5168717	PK-AB23120-KIT	Repair Kit, Items Marked **

** Available only in Repair Kit
◆◆: Only Available in Complete Assembly

TeeValve Control Valve Model: AA17L (5143295)

Model AA17L, used for selective control of 3-section boom sprayers at pressures up to 300 PSI.

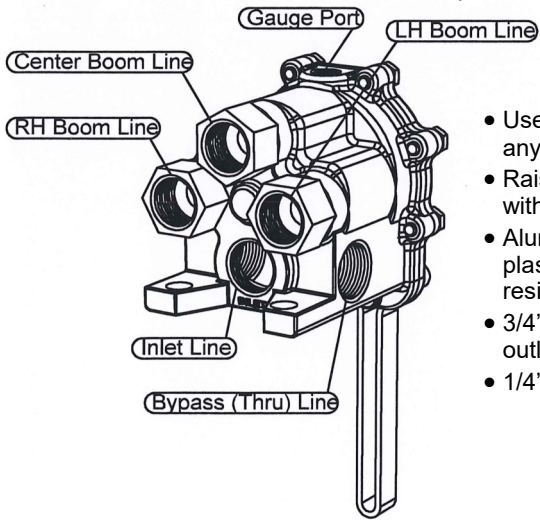

- Use to open any of three boom sections lines in any desired combination.
- Raise lever to open, lower lever to close the valve without changing the indexed position.
- Aluminum construction with stainless steel and plastic internal parts for maximum corrosion resistance.
- 3/4" NPT Inlet/Outlet, 3 boom outlet and accessory outlet.
- 1/4" NPT Gauge Port

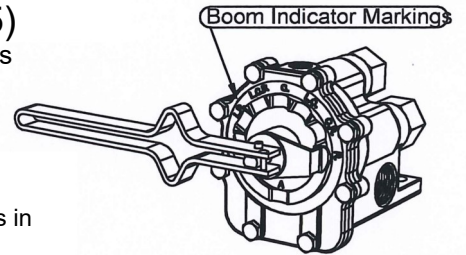

RH boom is 'selected'

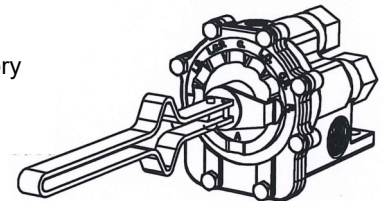

RH boom is 'activated'

TeeValve Sub-Assembly (5274766)

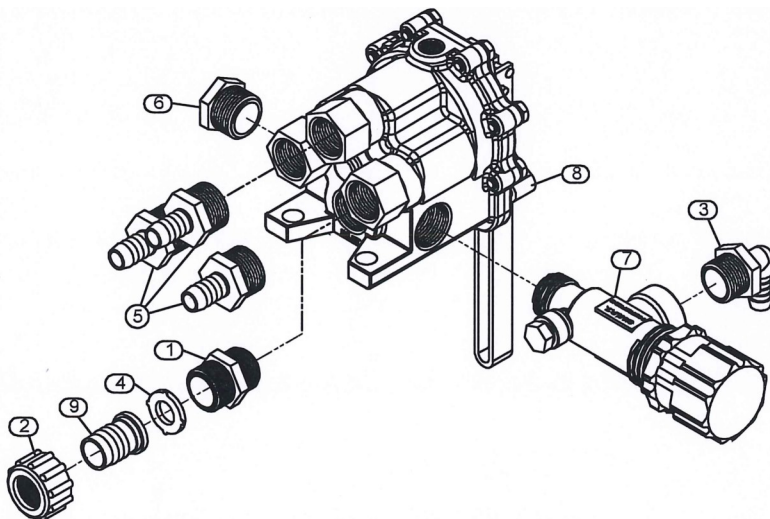

Ref. #	Part #	Description	Qty.
1	5005196	Poly Adapter, 3/4" MNPT x 3/4" MGHT	1
2	5006209	Poly Knurled Nut, 3/4" FGHT	1
3	5010207	Poly Elbow, 3/4" MPT x 1/2" HB	1
4	5016066	Garden Hose Washer	1
5	5067125	Poly Fitting, 3/4" MPT x 1/2" HB	3
6	5102071	Poly Pipe Plug, 3/4" MPT	1
7	5143199	Pressure Relief Valve (3/4" NPT)	1
8	5143295	TeeValve Assembly (AA-17L)	1
9	5149037	Poly Swivel, 3/4" Flat Seat Hose Barb	1

Exploded View:
 200-3PT-1PC
 (5300439)
 Refer to the parts list
 next page for part numbers.

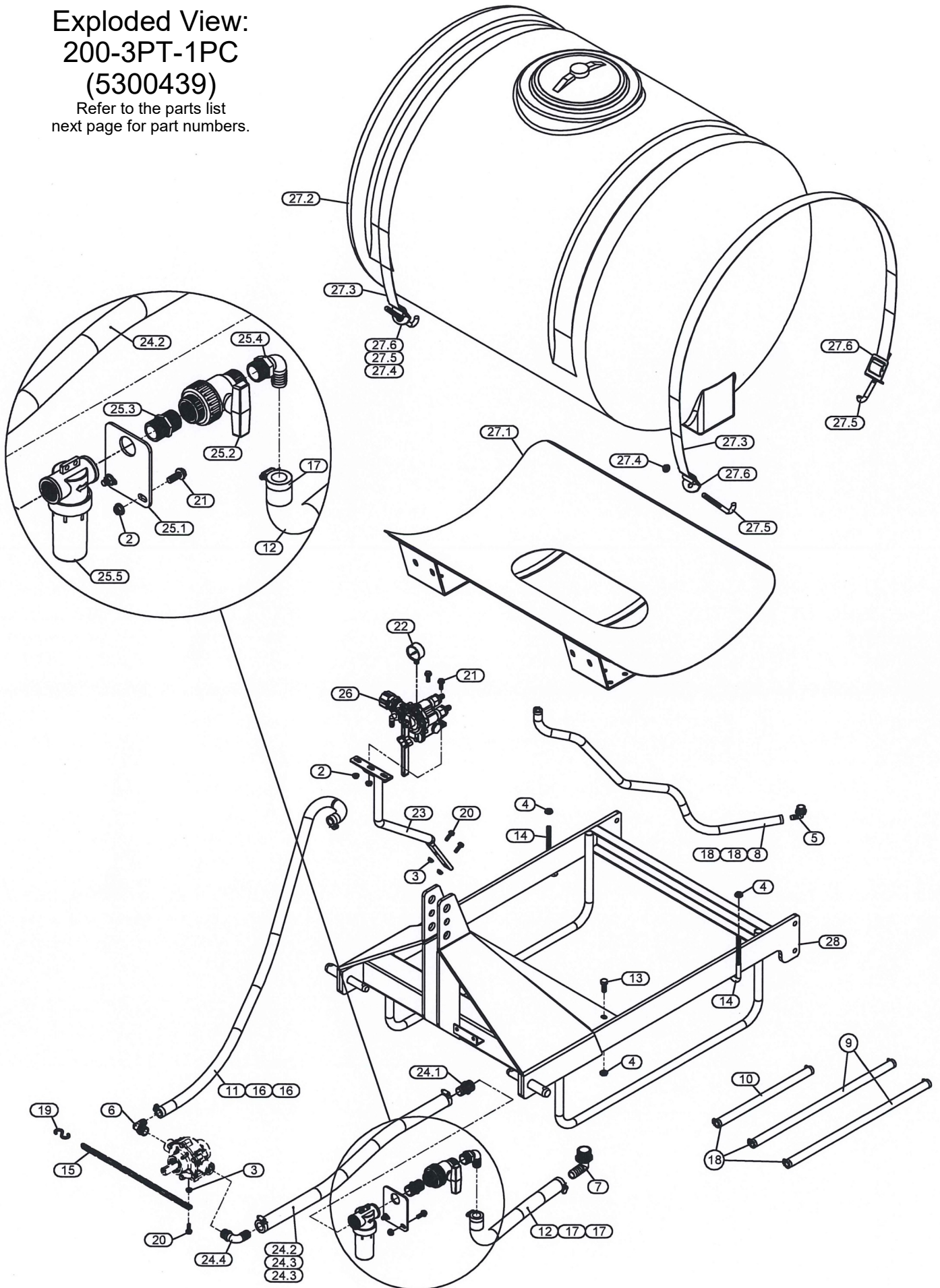

Parts List: 200-3PT-1PC (5300439)

Ref. #	Part #	Description	Qty.
1	5300658	8-Row Boom Assembly	1
2	5006259	3/8"-16nc Hex Flanged Whiz Nut, Grade 5	4
3	5006307	5/16"-18nc Hex Flanged Whiz Nut, Grade 5	3
4	5006337	1/2"-13 Hex Whiz (Flange) Locknut	4
5	5010207	Poly Elbow, 3/4" MPT x 1/2" HB	1
6	5010209	Poly Elbow, 3/4" MPT x 3/4" HB	1
7	5010215	Poly Elbow, 1-1/4" MPT x 1" HB	1
8	5020570	Hose, 1/2" x 4'	1
9	5020571	Hose, 1/2" x 11'	2
10	5020167	Hose, 1/2"-1 Brd. x 90"	1
11	5020179	Hose, 3/4"-2 Brd. x 6'	1
12	5020315	Hose, 1"-2 Brd. x 24"	1
13	5034019	H.H.C.S. 1/2"-13nc x 1-1/4"	2
14	5034111	1/2" x 6" J-Hook Bolt	2
15	5049017	Torque Chain, 24"	1
16	5051024	Hose Clamp, 3/4"	2
17	5051025	Hose Clamp, 1"	2
18	5051114	Hose Clamp, 1/2"	8
19	5082006	"S" Hook	1
20	5117300	H.H.C.S. Flanged 5/16"-18nc x 1"	3
21	5117307	H.H.C.S. Flanged 3/8"-16nc x 1"	4
22	5167005	Gauge, 0-400 PSI (Dry)	1
23	5272499	Valve Mount	1
24.1	5067118	Poly Fitting, 1" MPT x 1" HB	1
24.2	5020338	Hose, 1"-2 Brd. x 36"	1
24.3	5051025	Hose Clamp, 1"	2
24.4	5010210	Poly Elbow, 3/4" MPT x 1" HB	1
25	5274765	Strainer Sub-Assembly	1

Ref. #	Part #	Description	Qty.
25.1	5038247	Strainer Bracket	1
25.2	5143207	1" Single Union Ball Valve	1
25.3	5011141	Poly Close Nipple, 1" MNPT	1
25.4	5010213	Poly Elbow, 1" MNPT x 1" HB	1
25.5	5116441	1" Nylon Strainer (Black, 40 Mesh)	1
25.5.1	5058075	Strainer Bowl	1
25.5.2	5072229	EPDM Gasket	1
25.5.3	5116180	Screen, 40 Mesh	1
25.5.4	**	Strainer Cap	1
26	5274766	TeeValve Sub-Assembly	1
26.1	5143295	TeeValve Assembly (AA-17L)	1
26.2	5143199	Pressure Relief Valve (3/4" NPT)	1
26.3	5016066	Garden Hose Washer	1
26.4	5005196	Poly Adapter, 3/4" MNPT x 3/4" MGHT	1
26.5	5149037	Poly Swivel, 3/4" Flat Seat Hose Barb	1
26.6	5006209	Poly Knurled Nut, 3/4" FGHT	1
26.7	5067125	Poly Fitting, 3/4" MPT x 1/2" HB	3
26.8	5102071	Poly Pipe Plug, 3/4" MPT	1
26.9	5010207	Poly Elbow, 3/4" MPT x 1/2" HB	1
27.1	5273926	Saddle Weldment (38-200)	1
27.2	5169004	200 Gallon Tank (38" x 50" x 42")	1
27.2.1	63480	8" Lid w/Blue Snap-In Vent	1
27.3	5133103	Nylon Strap, 2" x 96"	2
27.4	5006337	1/2"-13 Hex Whiz (Flange) Locknut	4
27.5	5034111	1/2" x 6" J-Hook Bolt	4
27.6	5108041	Tank Strap Buckle, Bent	4
28	5273798	BB-32 3-PT Frame Weldment	1

** : Available ONLY in complete assembly

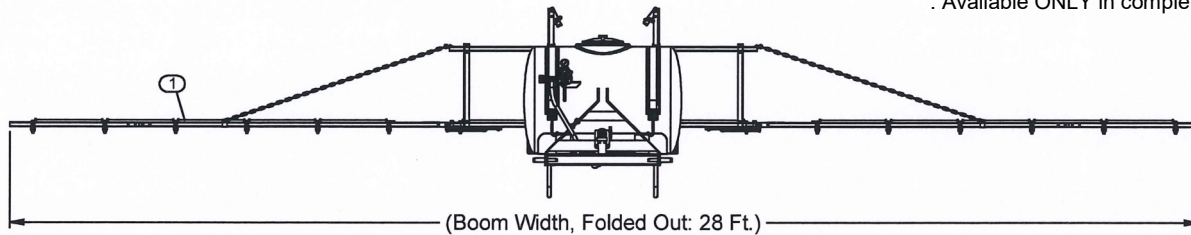

Back Rack Assembly (5277359)

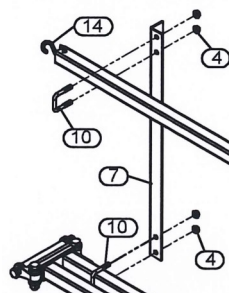

NOTE:

Assembly of opposite end is similar to this end.

Bolt (Item 8) goes through the yoke on the outer boom (s), then through Item 12 and 15, followed with jam locknut (Item 3).

For the eyebolt, thread the first nut (Item 1) onto the eyebolt, then feed it through the hole in the angle under the lower center section. Use the next nut for adjusting and the first nut for locking the eyebolt into position.

Ref. #	Part #	Description	Qty.
1	5006054	3/8"-16 Hex Nut	4
2	5006091	1/2"-13 Hex Locknut	4
3	5006142	1/2" Hex Jam Locknut	2
4	5006307	5/16"-18nc Hex Flanged Whiz Nut, Grade 5	8
5	5009635	Top Bar Tube	1
6	5019097	Hinge Spring	2
7	5022256	End Angle	2
8	5034074	H.H.C.S., 1/2"-13 X 7"	2
9	5034107	3/8" x 4" Eyebolt, Turned, Zinc Plated	2
10	5034159	Square U-Bolt, 5/16" x 1-5/16" x 1-7/8"	4
11	5034308	H.H.C.S., 1/2"-13 X 2-1/4"	4
12	5080011	Outer Hinge Section	2
13	5080012	Center Hinge Section	2
14	5082006	"S" Hook	2
15	5271580	Spring Connector Weldment	2
16	5273315	Center Boom Weldment	1

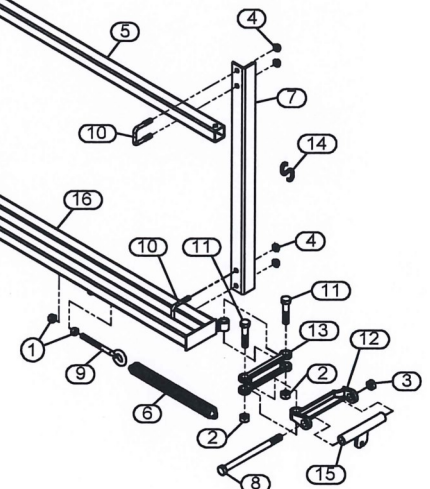

Model: 257-8 (8-Row)
 Boom Assembly
 (5300658)

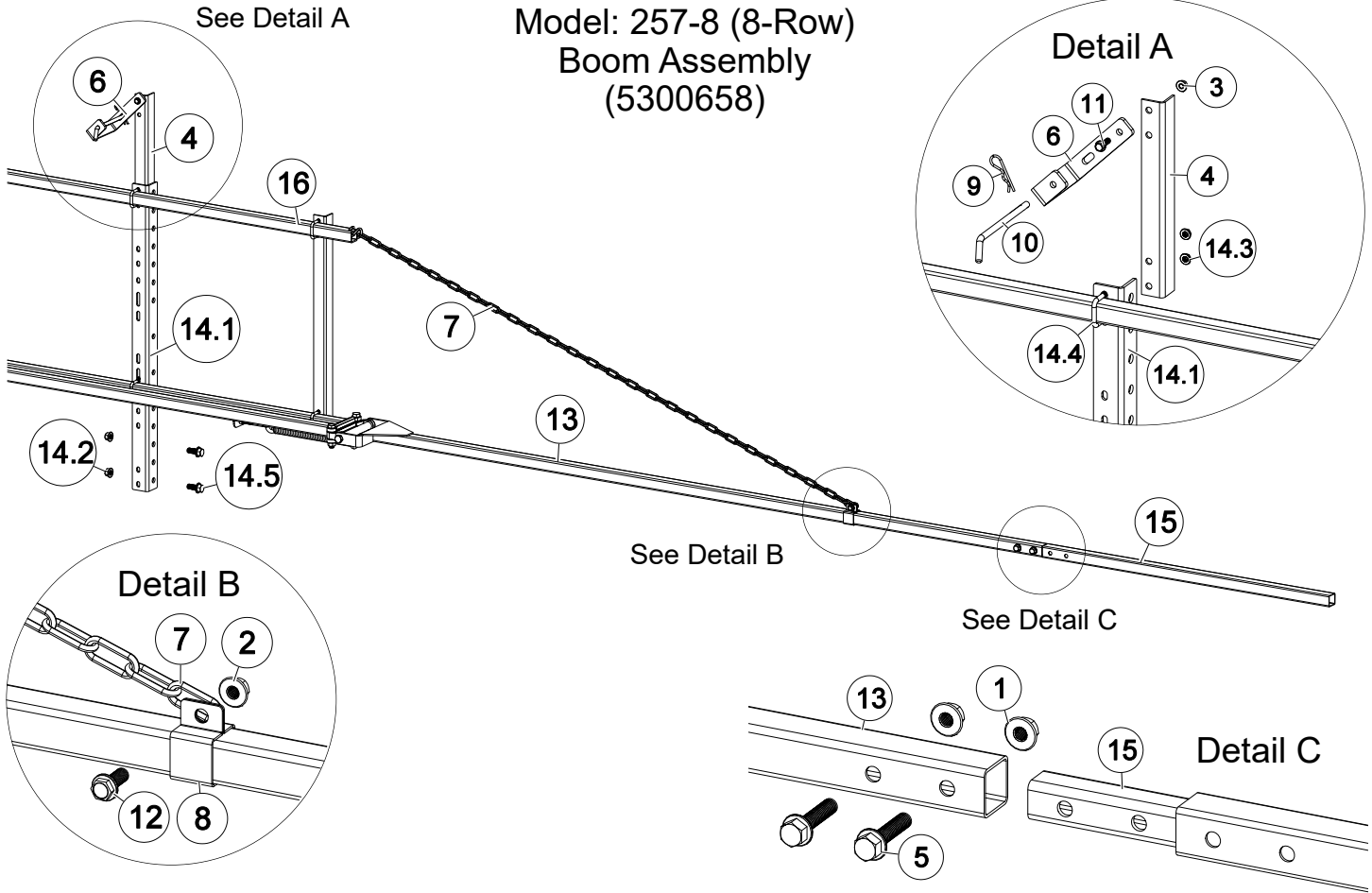

Ref. #	Part #	Description	Qty.
1	5006345	3/8"-16nc Hex Flanged Toplock Nut, Grade 5	4
2	5006259	3/8"-16nc Hex Flanged Whiz Nut, Grade 5	2
3	5006389	5/16"-18nc Hex Flanged Toplock Nut	2
4	5022238	Mounting Angle	2
5	5034664	3/8"-16 x 1-3/4"	4
6	5038317	U-Bracket	2
7	5049018	Boom Chain (7 Ft.)	2
8	5051085	Slide Clamp	2
9	5101065	#211 Hitch Pin Clip (Zinc Plated)	2
10	5101231	Pin	2
11	5117300	H.H.C.S. Flanged 5/16"-18nc x 1"	2
12	5117307	H.H.C.S. Flanged 3/8"-16nc x 1"	2
13	5273313	End Boom Weldment	2

Ref. #	Part #	Description	Qty.
14	5275256	Upright Assembly	2
14.1	5022255	Boom Upright Angle	1
14.2	5006365	1/2"-13 Hex Whiz (Flange) Locknut	2
14.3	5006307	5/16"-18nc Hex Flanged Whiz Nut, Grade 5	4
14.4	5034159	Square U-Bolt, 5/16" x 1-5/16" x 1-7/8"	2
14.5	5034691	H.H.C.S. 1/2"-13 x 1-1/4"	2
15	5275736	8-Row Boom Extension	2
16	5277359	257 Back Rack Assembly	1
17	5277894	257-8 Nozzle Harness (Complete)	1
17.1	5277761	Center Nozzle Harness Assembly (STD)	1
17.2	5277812	LH End Nozzle Harness Assembly (STD)	1
17.3	5277806	RH End Nozzle Harness Assembly (STD)	1

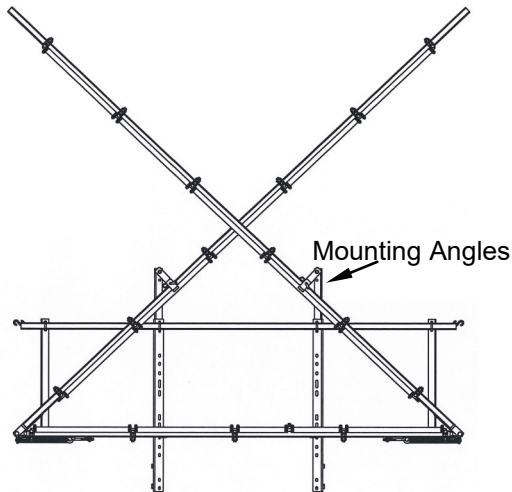

Center "Back-Rack" Mounted
 In "High" Position

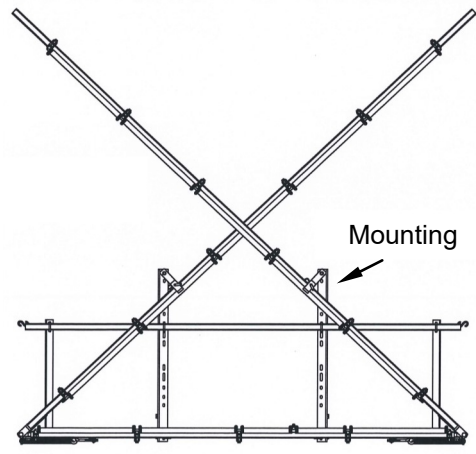

Center "Back-Rack" Mounted
 In "Low" Position

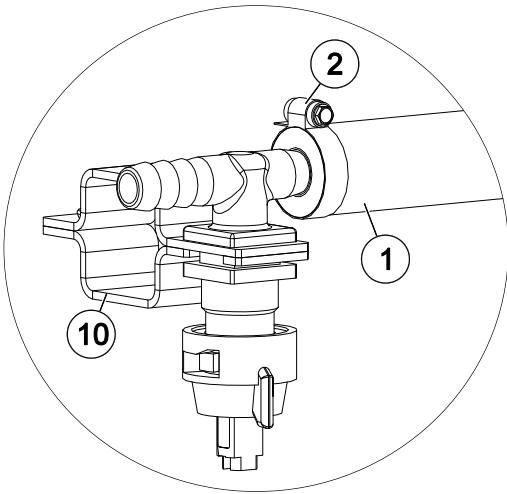
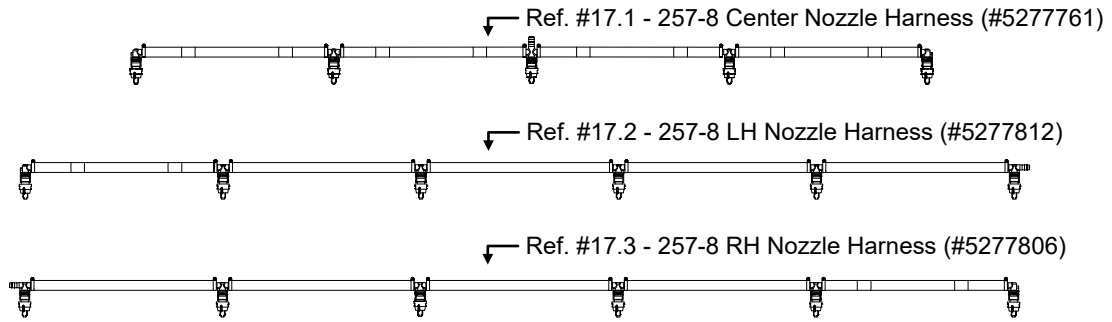

Ref. #	Part #	Description	Qty.
1	5020569	Hose, 1/2"-1 Brd. x 19-3/8"	14
2	5051114	Hose Clamp, 1/2"	28
3	5056065	Single Hose Shank (1/2" Hose)	4
4	5056067	Double Hose Shank (1/2" Hose)	12
5	5056069	Triple Hose Shank (1/2" Hose)	1
6	5143543	Check Valve Strainer, 50 Mesh, 5 PSI	17
7	5016157	Seat Washer (QJ Caps)	17
8	AIXR11003VP	Air-Induction XR Flat Spray Tip	17
9	5046217	QJ Cap Only (Blue)	17
10	5272165	Vari-Quick Clamp (1-1/4" Sq. Tube)	17

NOTES:

All hoses in this boom assembly are part #5020569 (Item 1)

All hose clamps (2 per hose) are #5051114 (Item 2)

The AIXR TeeJet Flat Spray Tip offers the benefits of obtaining excellent drift resistance without compromising spray coverage. Tips producing very coarse droplets do minimize drift but do not provide the same surface coverage as tips that produce smaller droplets. In some applications, inadequate coverage decreases the effectiveness of the applied chemicals.

AIXR Features and Benefits

- 110° wide, tapered flat spray angle with air induction technology for better drift management
- Made of 2-piece UHMWPE polymer construction which provides excellent chemical resistance, including acids, as well as exceptional wear life
- Compact size to prevent tip damage
- Removable pre-orifice
- Excellent for systemic products and drift management

Typical Nozzle Assembly Configurations

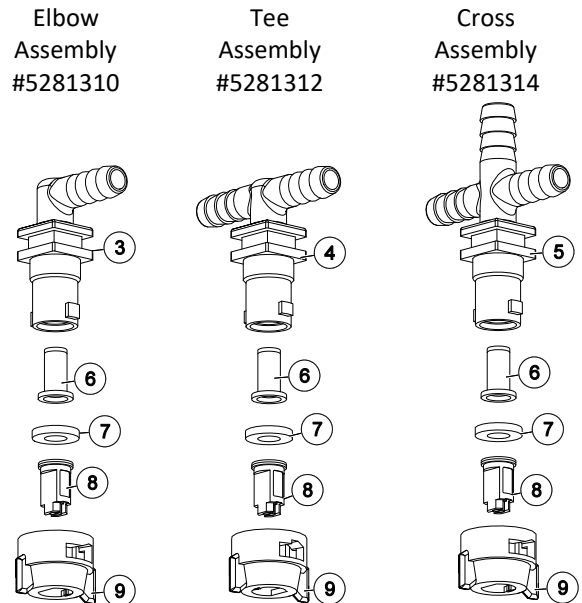

Nozzle Assemblies consist of "Elbow", "Tee" & "Cross" style nozzles.

Assemblies include: Nozzle Body, Strainer, Seat Washer, AIXR11003VP Nozzles & Nozzle Cap

NOTES:

Warranty

LIMITED WARRANTY FOR NEW FIMCO, INC.

WHO MAY USE THIS LIMITED WARRANTY. This limited warranty (the "Limited Warranty") is provided by Fimco, Inc. to the original purchaser ("you") of the Equipment (as defined below) from Fimco, Inc. or one of Fimco, Inc.'s authorized dealers. This Limited Warranty does not apply to any subsequent owner or other transferee of the Equipment. THIS LIMITED WARRANTY GIVES YOU SPECIFIC LEGAL RIGHTS, AND YOU MAY ALSO HAVE OTHER RIGHTS WHICH VARY FROM STATE TO STATE.

WHAT THIS LIMITED WARRANTY COVERS AND FOR HOW LONG. Fimco, Inc. warrants that any new Equipment will be free from defects in material and workmanship for a period of **one (1) year** (homeowner), **90 days** (commercial user), after delivery of the Equipment to you (the "Warranty Period"). The Warranty Period is not extended if Fimco, Inc. repairs or replaces the Equipment.

WHAT IS NOT COVERED BY THIS LIMITED WARRANTY. This Limited Warranty does not apply to: (1) used Equipment; (2) any Equipment that has been altered, changed, repaired or treated since its delivery to you, other than by Fimco, Inc. or its authorized dealers; (3) damage or depreciation due to normal wear and tear; (4) defects or damage due to failure to follow Fimco, Inc.'s operator's manual, specifications or other written instructions, or improper storage, operation, maintenance, application or installation of parts; (5) defects or damage due to misuse, accident or neglect, "acts of God" or other events beyond Fimco, Inc.'s reasonable control; (6) accessories, attachments, tools or parts that were not manufactured by Fimco, Inc., whether or not sold or operated with the Equipment; or (7) rubber parts, such as tires, hoses and grommets.

HOW TO OBTAIN WARRANTY SERVICE. To obtain warranty service under this Limited Warranty, you must (1) provide written notice to Fimco, Inc. of the defect during the Warranty Period and within **thirty (30)** days after the defect becomes apparent or the repair becomes necessary, at the following address: Fimco, Inc., 1000 Fimco Lane, North Sioux City, SD 57049; and (2) make the Equipment available to Fimco, Inc. or an authorized dealer within a reasonable period of time. For more information about this Limited Warranty, please call: **800-831-0027**

WHAT REMEDIES ARE AVAILABLE UNDER THIS LIMITED WARRANTY. If the conditions set forth above are fulfilled and the Equipment or any part thereof is found to be defective, Fimco, Inc. shall, at its own cost, and at its option, either repair or replace the defective Equipment or part. Fimco, Inc. will pay for shipping and handling fees to return the repaired or replacement Equipment or part to you.

LIMITATION OF IMPLIED WARRANTIES AND OTHER REMEDIES. THE REMEDIES DESCRIBED ABOVE ARE YOUR SOLE AND EXCLUSIVE REMEDIES, AND FIMCO, INC.'S SOLE LIABILITY, FOR ANY BREACH OF THIS LIMITED WARRANTY. TO THE EXTENT APPLICABLE, ANY IMPLIED WARRANTIES, INCLUDING, WITHOUT LIMITATION, THE IMPLIED WARRANTIES OF MERCHANTABILITY AND FITNESS FOR A PARTICULAR PURPOSE, SHALL BE LIMITED IN DURATION TO THE WARRANTY PERIOD, AND THE REMEDIES AVAILABLE FOR BREACH THEREOF SHALL BE LIMITED TO THE REMEDIES AVAILABLE UNDER THIS EXPRESS LIMITED WARRANTY. SOME STATES DO NOT ALLOW LIMITATIONS ON HOW LONG AN IMPLIED WARRANTY LASTS, SO THE ABOVE LIMITATION MAY NOT APPLY TO YOU. IN NO EVENT SHALL FIMCO, INC.'S LIABILITY UNDER THIS LIMITED WARRANTY EXCEED THE ACTUAL AMOUNT PAID BY YOU FOR THE DEFECTIVE EQUIPMENT, NOR SHALL FIMCO, INC. BE LIABLE, UNDER ANY CIRCUMSTANCES, FOR ANY CONSEQUENTIAL, INCIDENTAL, SPECIAL OR PUNITIVE DAMAGES OR LOSSES, WHETHER DIRECT OR INDIRECT. SOME STATES DO NOT ALLOW THE EXCLUSION OR LIMITATION OF INCIDENTAL OR CONSEQUENTIAL DAMAGES, SO THE ABOVE LIMITATION OR EXCLUSION MAY NOT APPLY TO YOU.