

# OWNER'S MANUAL

**Model: 20V-25-700-ATV (5303076)**

(25 Gallon Lawn & Garden/ATV Sprayer w/Volt Edge System)

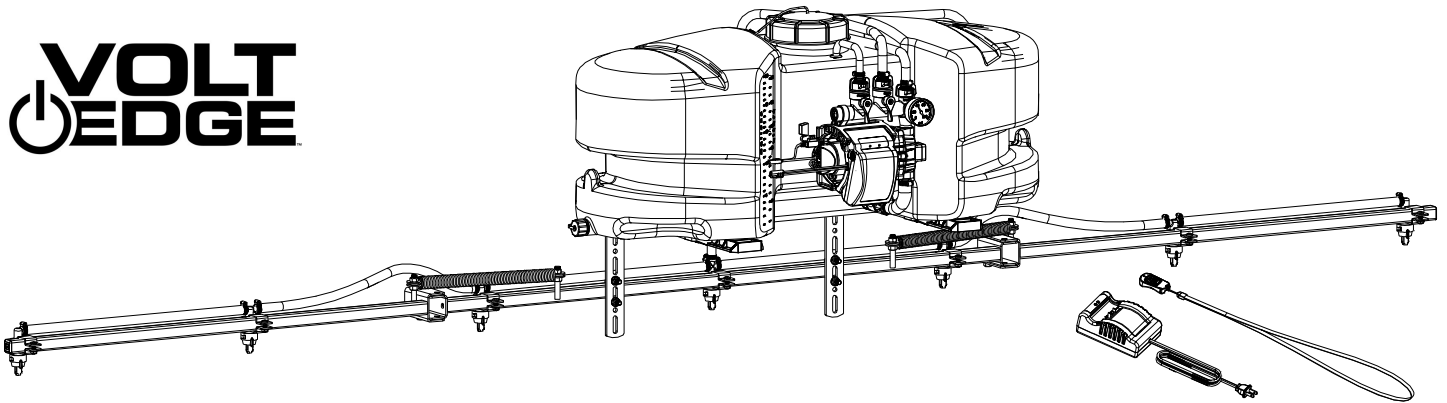

## General Information

Thank you for purchasing this product. The purpose of this manual is to assist you in operating and maintaining your lawn & garden ATV sprayer.

**BEFORE RETURNING THIS PRODUCT  
FOR ANY REASON, PLEASE CALL**

**1-800-831-0027**

MONDAY-FRIDAY, 8:00 AM TO 5:00 PM CST

If you should have a question or experience a problem with your Fimco Industries Product: Visit our website @ [www.fimcoindustries.com](http://www.fimcoindustries.com) or call the Toll free number above. Our technical support representatives will be happy to help you. In most cases a customer service rep. can resolve the problem over the phone.

To obtain prompt, efficient service, always remember to give the following information....

- Correct Part Description and/or part number
- Model number and Serial Number

Part descriptions and numbers can be obtained from the illustrated parts list section(s) of this manual.

**Retain a copy of your receipt for your unit, as it will be required to validate any warranty service.**

Warranted against manufacturer or workmanship defects from date of purchase with copy of receipt:



Homeowner Usage: Sprayer-One Year and Pump-Two Years.

Commercial Usage: Sprayer and Pump-90 Days.



**WARNING:** To reduce the risk of injury, the user must read and understand the operator's manual before using this product.



**WARNING:** Cancer and Reproductive Harm.  
[www.P65Warnings.ca.gov](http://www.P65Warnings.ca.gov)

## \*\*\*IMPORTANT REMINDER\*\*\*

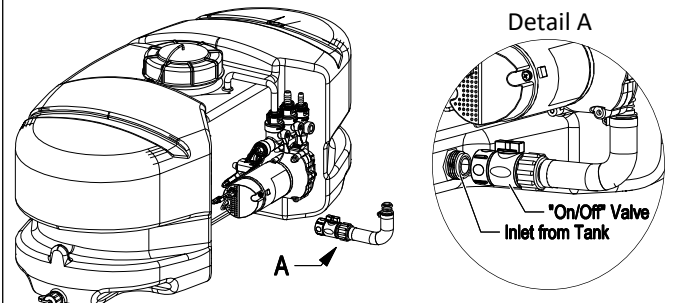

This sprayer comes with an On/Off (shut-off) valve located at the inlet location of the tank, towards the underside. (See Detail A). Make sure the valve is in the "open" position before using this sprayer.



[www.fimcoindustries.com](http://www.fimcoindustries.com)

1000 FIMCO Lane, P.O. Box 1700, North Sioux City, SD 57049  
Toll Free Phone: 800-831-0027 : Toll Free Fax: 800-494-0440

[5195283

(10/22)]

## Contents

Technical Specs .....	2	VoltEdge Battery Info .....	12 - 13
Sprayer Contents .....	3	VoltEdge Charging Procedure .....	14
Sprayer Assembly Instructions .....	4 - 6	VoltEdge Operating, Diagnostics and Pairing.....	15
Sprayer Operation .....	7	VoltEdge Battery Kit Exploded View/Parts List.....	17
Calibration, Maintenance and Tank Care .....	8	VoltEdge Troubleshooting.....	17
Storing and Winter Storage .....	9	Sprayer Exploded View/Parts List .....	18
Pump Exploded View/Parts List.....	10	Boom Exploded View/Parts List .....	19
Pump Troubleshooting .....	10 - 11	Dimensions and Warranty.....	20

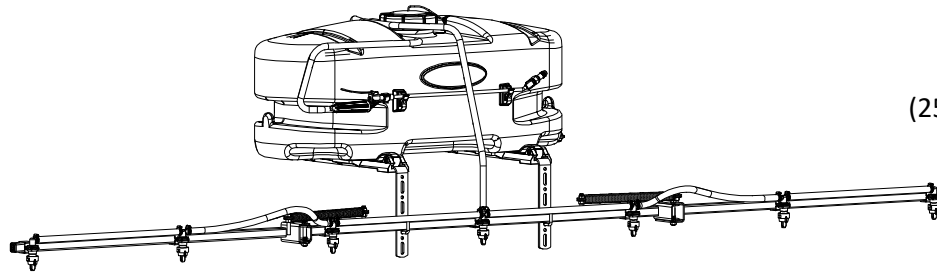

## Model: 20V-25-700-ATV (5303076)

(25 Gallon Lawn & Garden/ATV Sprayer  
w/Volt Edge System)

### Technical Specifications

- 25 Gal. Corrosion-Resistant Polyethylene Tank
- 12 Volt Diaphragm Pump, 2.4 GPM - 60 PSI
- Volt Edge 20Vmax Lithium Ion System  
4 Tanks, 72 Minutes Spraying &  
100 Gallons per Charge
- 20 Ft. Handgun Hose (3/8" I.D.)
- 25 Ft. Vertical throw, 40 Ft. Horizontal Throw
- 7-Nozzle Boom Assembly (140" Spray Coverage)
- Fold-Away Outer Boom Members
- Corrosion-Resistant Nylon Nozzles
- Check Valve Strainers, 50 Mesh, 5 PSI

**CAUTION: When fully filled with water, this sprayer will weigh approx. 270 Lbs.  
Always check the vehicle load rating before using this sprayer. Do not exceed the recommended rating.**

### ~~~~~IMPORTANT~~~~~

Remove tank lid and be sure the tank is clean and free of any foreign material. Rinse tank out of any tank residue before filling with water to test.

### ~~~~~IMPORTANT~~~~~

It is VERY important to test this sprayer with plain water before actual spraying is attempted. This will enable you to check the sprayer for leaks without the possibility of losing any expensive chemicals.

### ~~~~~WARNING~~~~~



**Read and Understand** the Owner's Manual before using this sprayer. Test and use in accordance to instructions.  
**Read and Follow** chemical label instructions and wear protective gear when filling, using, cleaning and servicing the sprayer.

**Exercise Caution** in vehicle handling when towing/hauling a filled sprayer to avoid loss of control or overturning.  
**Keep Sprayer and Spray materials** away from other people, children and pets.  
**Do Not Turn on Power** to the sprayer, until ready to spray in order to avoid unintentional spray release.  
**Do Not Use** on steep slopes. A full sprayer could cause loss of control or overturn sprayer and vehicle.  
**Always operate** up and down a slope, never across the face of a slope.  
**Keep all movement on slopes** slow and gradual. Do not make sudden changes in speed, directions or turning. Do not start or stop suddenly when going uphill or downhill.  
**Stop on level ground**, set the parking brake and shut off engine before leaving the operator's position for any reason.  
**Keep all parts** in good condition and properly installed. Fix damaged or worn parts immediately.  
**Caution should be taken** when towing and/or using any sprayer. This sprayer combined with the weight distribution, turning radius and speed of vehicle can result in damage to vehicle and/or sprayer or severe injury or death, if not used properly.  
**Improper use of this sprayer or handling of chemicals could result in serious injury or illness, or could cause damage to the environment.**

# Sprayer Contents:

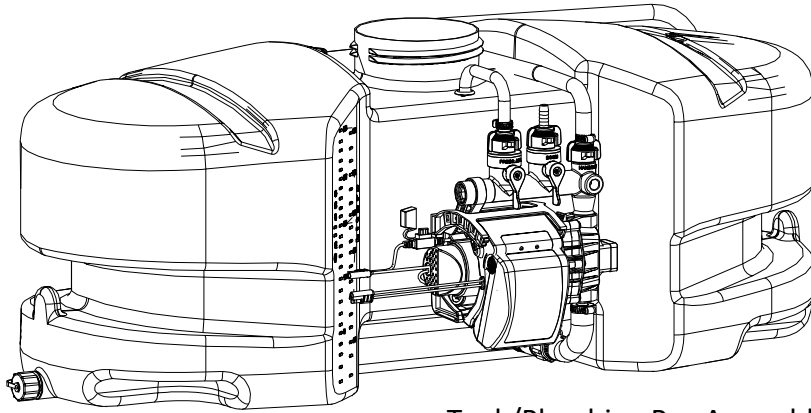

Tank/Plumbing Pre-Assembly

Owner's Manual



Tank Lid & Lanyard

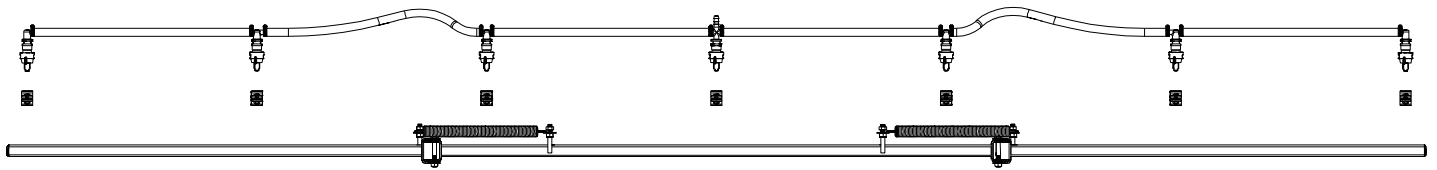
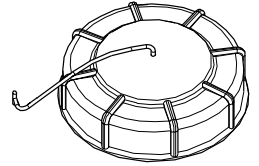

7-Nozzle Boom, 7-Nozzle Harness & Nozzle Clamps/Pkg. of 7

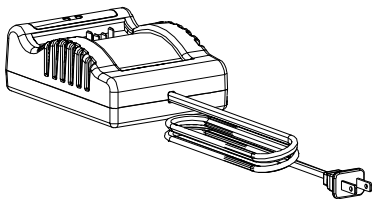

20V, 1A Lithium Battery Charger

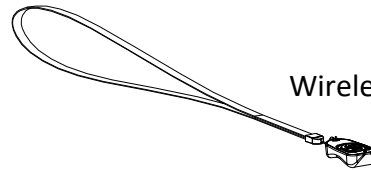

Wireless Remote

## Contents of Parts Bag (#5281556)

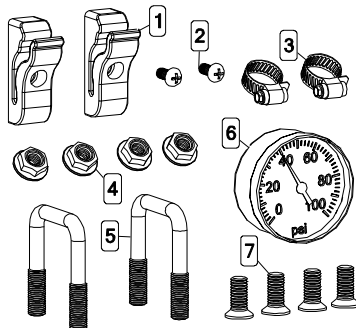

Ref. #	Part #	Description	Qty
1	5053096	Spray Wand Clip	2
2	5117334	#10-24 x 0.50 PH Round Head Screw	2
3	5051144	Hose Clamp (3/8")	2
4	5006307	5/16-18 Serrated Flange Hex Nut	4
5	5034159	5/16-18 x 1.3125 x 1.875 Square U-Bolt	2
6	5167097	2" Dry 100# Back Mount Pressure Gauge	1
7	5034149	5/16-18 x 0.75 PH Flat Head Screw	4

## Contents of Bracket Kit (#5278133)

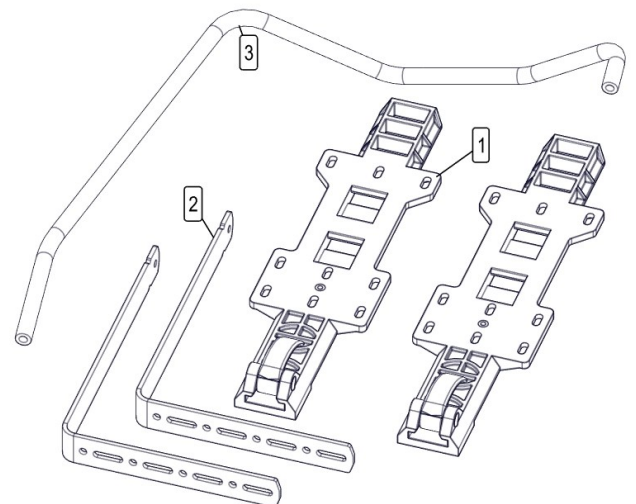

Ref. #	Part #	Description	Qty
1	5278222	ATV Quick Release Bracket	2
1.1	5078223	Cam Handle Assembly	2
2	5038872	QR Bracket - Bent Adjustable Height	2
3	5020161	Hose, 3/8"-1 Brd. x 48"	1

## Assembly Procedure

### Step 1

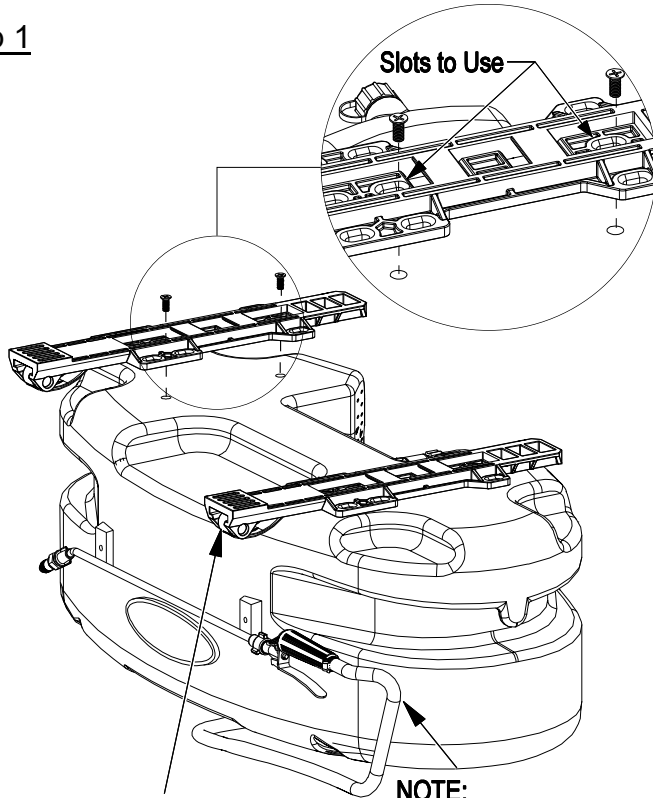

(\*\*) 'Long' portion of the brackets should be facing towards the 'back' side of the tank (opposite of the pump/manifold assembly)

**NOTE:** The Spray Wand will already be attached to the spray line hose

- Make sure the contents of the sprayer's carton match the items shown on page 3 of the manual.
- Follow the steps on pages 4, 5 & 6 to properly assemble the sprayer.

Normally, the sprayer will be mounted on an ATV with the pump assembly at the operator's back and the spray wand will be at the rear of the unit. Right Hand (RH) and Left Hand (LH) sides of the sprayer are determined as if you are standing behind the sprayer, looking at it (facing forward)

After removing the tank from the box, start the assembly procedure by turning the tank upside down on a stable, flat surface.

**A phillips head screwdriver is required for this step.**

(\*\*) Mount tank brackets to the underside of the tank as shown in Step 1. Use (4) flat head screws to secure it to the tank. The tank will rest on the surface of the brackets. Make sure the brackets are parallel with each other before tightening down the bolts. Do not over-tighten.

### Step 2

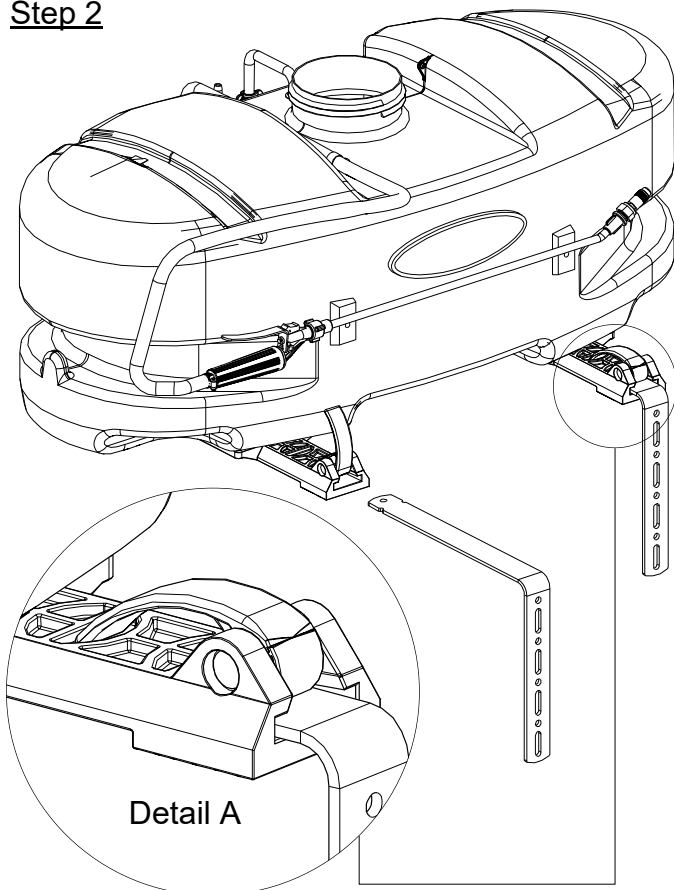

After your tank brackets are securely attached, turn the tank assembly over and position it so that the cam handles which extend beyond the back of the tank are facing you and just hanging over the edge of the table or flat surface you are assembling this on.

Secure the boom mounting brackets to the tank mounting brackets with Cam handles as shown in Detail A. You can position them as needed within the slot on the bracket. Just be sure that the surfaces of both brackets are even with each other.

You are now ready to mount this unit to an ATV, using ratchet straps (NOT INCLUDED)

## Assembly Procedure

### Step 3

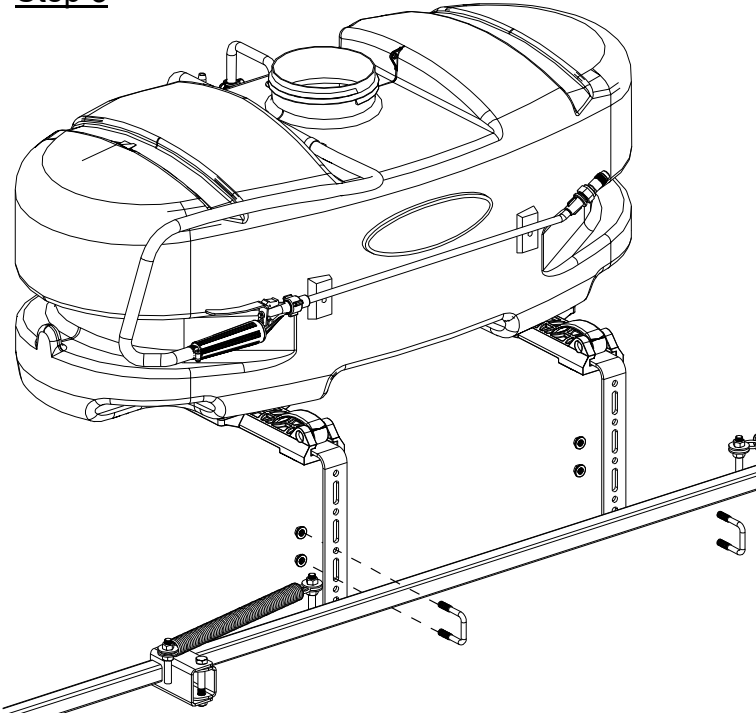

After your boom mounting brackets are secured in place and the unit secured on your ATV, bolt the 7-nozzle boom in place with (2) Square U-Bolts and whiz nuts.

**A 1/2" socket or wrench is required for this step.**

This boom can be positioned as shown or in a few alternate positions.

Try to maintain approximately 18-22 inches above the items being sprayed, for optimal coverage. This is considered where the nozzles will mount, at the end of these brackets.

### Step 4

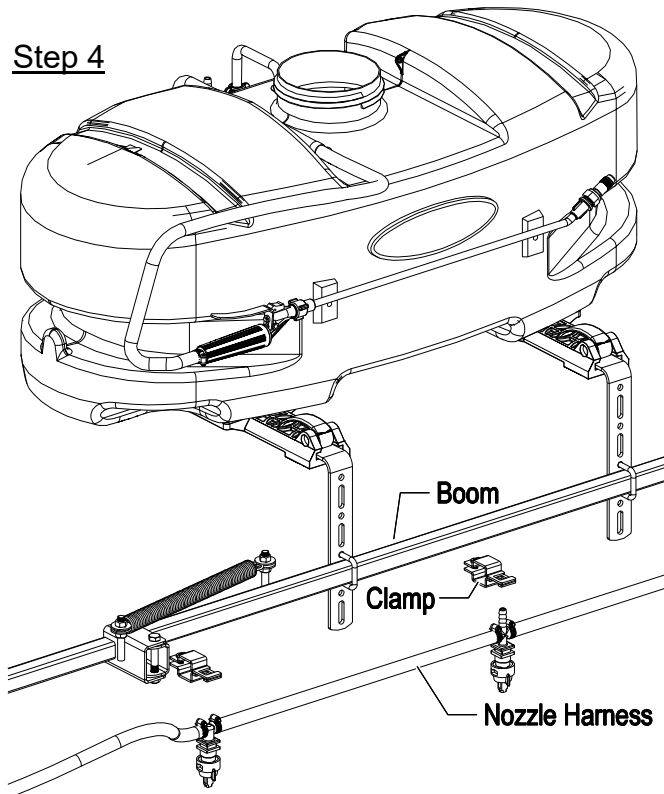

With the boom secured to the boom mounting brackets, the nozzle harness can now be attached.

Attach the nozzle harness to the boom. Starting with center nozzle, center the harness on the boom and using the nozzle clamps, attach the nozzle harness to the boom as shown in **DETAIL Clamp**. Attach remaining nozzles to complete installation.

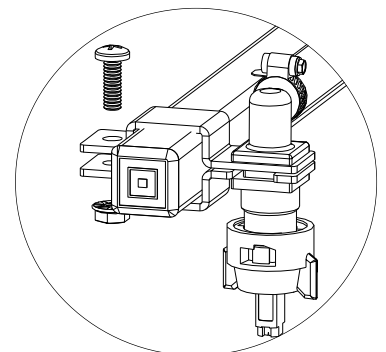
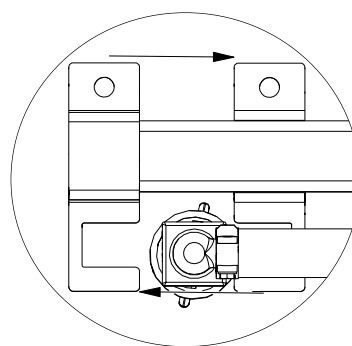
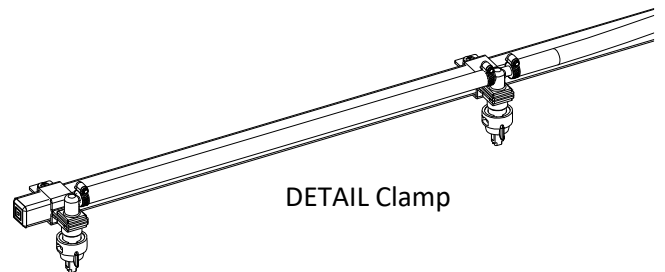

## Assembly Procedure

After your nozzle harness is attached to the boom, locate the 48" hose and the (2) hose clamps from the parts bag.

Place the hose clamps over each end of the hose loosely. Slip the ends of the hose over the hose barbs on both the manifold and the 'CROSS' fitting on the nozzle harness. Use a twisting motion, if necessary, to get the hose fully onto each barb. Bring the hose clamps to the connection point and tighten securely.

**NOTE:**

Make sure this boom feeder hose does not end up on the 'outside' of the spray wand hose, otherwise unwrapping the spray wand hose from around the tank may be difficult.

**Detail A:** Install the pressure gauge. Hand tighten securely.  
**\*\* DO NOT OVER-TIGHTEN \*\***

**Detail B:** Screw the lid onto the tank. Place the end of the lanyard through the tab in the tank. This is so the lid can 'hang' off the tank when filling/rinsing the tank out.

**Detail C:** Locate the (2) clips and (2) phillips head screws from the parts bag.

**A phillips head screwdriver is required for this step**

Place a screw through the hole in the clip and bring it up to the tank, where the embossments for the clips are (located on the rear side of the tank)

Secure the clip/screw to the tank. Tighten so that the clip is secure. Do this for each clip.

**\*\* DO NOT OVER-TIGHTEN \*\***

The spray wand will snap into the clips once installed. Do not use excessive force when placing the spray wand into the clips, as this could cause the clips to break.

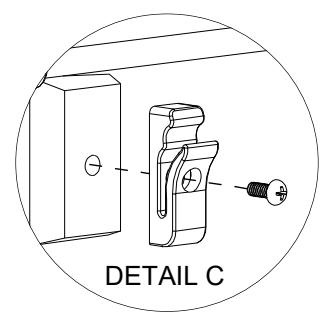
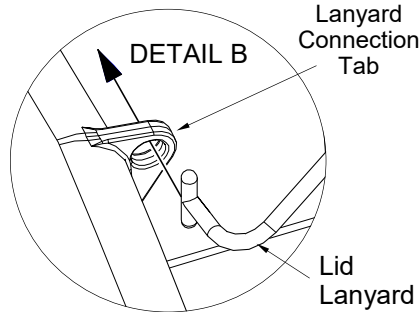
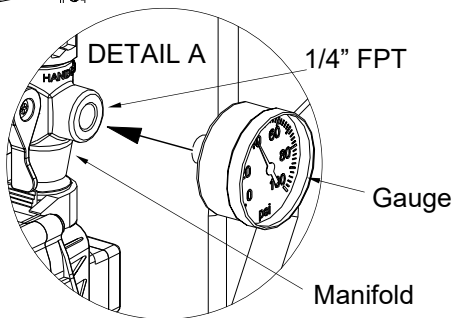
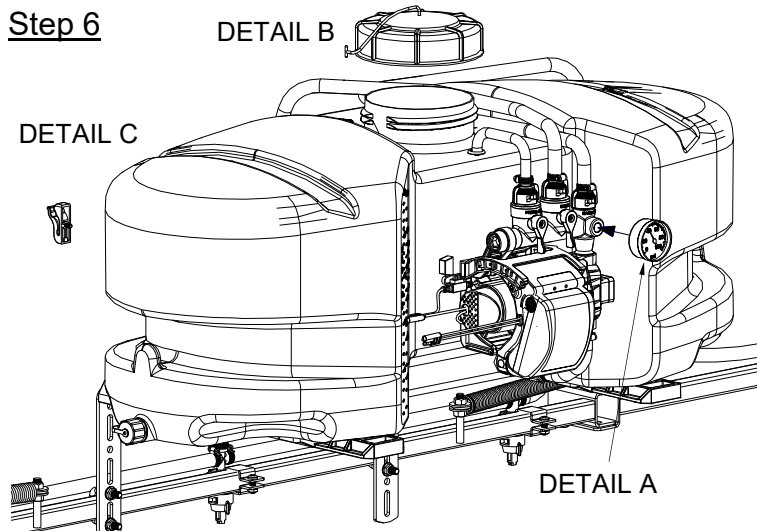
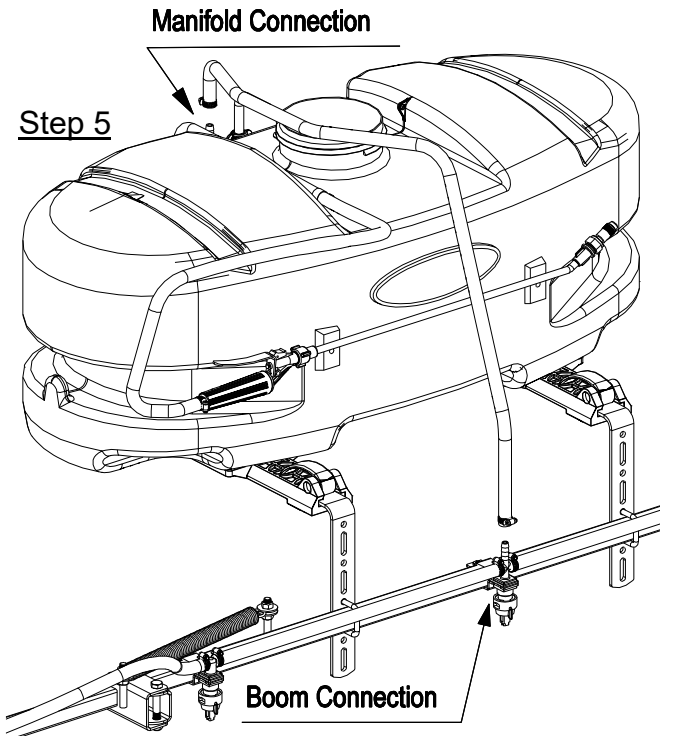

- Make sure all hose clamps are tight before testing or spraying for the first time.
- The drain plug assembly should already be attached to the tank
- Read the operating instructions for both the sprayer and the Volt Edge system before using.

**\*\*The Sprayer is now Ready to TEST w/plain water before Actual Use\*\***

**IMPORTANT:** Remove tank lid and be sure the tank is clean and free of any foreign material. Rinse tank out of any tank residue before filling with water to test.

### Testing the Sprayer

#### NOTE:

It is VERY important to test the sprayer with plain water before actual spraying is attempted. This will enable you to check the sprayer for leaks without the possibility of losing any expensive chemicals.

Fill the tank about 1/2 full with plain water and drive to the starting place for spraying.

When you are ready to spray, turn the boom valve to the “on” position (Detail A). This will start solution spraying from the tips of the boom. The pressure will decrease slightly when the boom is spraying. Adjust the pressure by turning the “ON/OFF” valve lever on the Press. Adj. (bypass) valve (Detail B). Make sure your pattern is sufficient. You may down-pressure the system by ‘bypassing’ solution back into the tank. This is achieved by opening the Press. Adj. (bypass) valve. Regulating pressure is done in this manner.

Read the operating instructions and initially begin spraying by closing the ‘Pressure Adjust’ valve and opening the boom line valve (Detail A). This will enable the air in the line to be eliminated (purged) through all the tips, while building pressure. When everything tests all right (no leaks and good pressure), add the desired chemicals to the mixture and water combination and start your spraying operation. Adjust the pressure and spray as you did in the testing procedure. Conditions of weather and terrain must be considered when setting the sprayer. Do not spray on windy days. Protective clothing must be worn in some cases.

**Be sure to read the chemical label(s) before application!**

### Operation

The pumping system draws solution from the tank, through the strainer and to the pump. Pump forces the solution under pressure to the handgun or boom nozzles.

**NOTE:** Read and follow the Volt Edge instructions, later in this manual, for charging and operation of the 20Vmax Lithium Ion System.

Fill the tank part way with water and then add the desired amount of chemical to be sprayed. Finish filling tank to proper level.

**Only fill the tank with what you’re going to spray in a day, never leave chemicals sit in tank.**

Turn the pump on and by depressing the ON button. The pump is equipped with a pressure switch that is pre-set at the factory to shut the pump off when all discharges are closed.

The pump will turn back on when one of the following actions occurs:

- ◆ Handgun lever is squeezed to spray the handgun.
- ◆ Boom valve is opened to broadcast spray with the boom.
- ◆ Press. Adj. (bypass) valve is opened to re-circulate solution back into the tank.

When spraying with either the boom or the handgun, pressure may be reduced by slowly opening the Press. Adj. (bypass) valve until desired pressure is achieved. Opening the valve decreases pressure, closing the valve increases pressure. When spraying with the boom, the proper method to set the pressure is to open the boom valve completely and if a lower pressure is desired, then slowly open the bypass valve until that pressure is obtained.

For the safest and most efficient chemical application, you will need to calibrate your sprayer using the tip and speed charts. Once you have determined the proper speed and pressure settings, you will need to consult your chemical label for the amount of chemical to be added to the tank. Read the entire label. Use only according to label directions.

### Using the Boom Nozzles

Four things must be considered before spraying with the boom.

1. How much chemical must be mixed in the tank.
  2. Rate of spray (gallons per acre to be sprayed).
  3. What pressure (p.s.i.) will be used.
  4. Speed traveled (mph) while spraying.
- \* Refer to the chemical label to determine your chemical mixture
  - \* See the tip chart to determine the pressure to be used. The chart will also show the speed used when spraying.
  - \* Start the pump and open the valve to the boom nozzles.
  - \* Check the spray pattern. Usually you can see the coverage better on a solid concrete surface, such as a driveway.

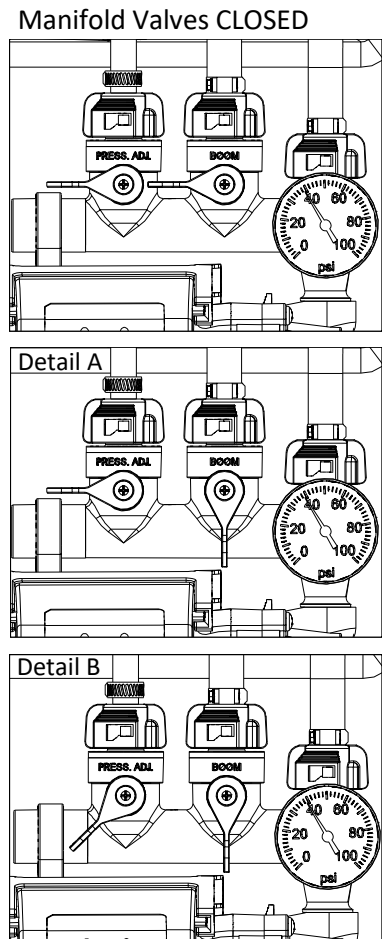

## Calibration

Chemical labels may show application rates in gallons per acre, gallons per 1000 square feet or gallons per 100 square feet. You will note that the tip chart shows 2 of these rating systems. Once you know how much you are going to spray, then determine (from the tip chart) the spraying pressure (PSI), and the spraying speed (MPH).

Determining the proper speed of the pulling vehicle can be done by marking off 100, 200 & 300 feet. The speed chart indicates the number of seconds it takes to travel the distances. Set the throttle and with a running start, travel the distances. Adjust the throttle until you travel the distances in the number of seconds indicated by the speed chart. Once you have reached the throttle setting needed, mark the throttle location so you can stop and go again, returning to the same speed.

Add water and proper amount of chemical to the tank and drive to the starting place for spraying.

AIXR11002VP Spray Tip Rate Chart (20" Spacing)										
	Pressure (psi)	Capacity (GPM)	1 MPH	2 MPH	3 MPH	4 MPH	5 MPH	6 MPH	8 MPH	10 MPH
Gallons Per Acre Based on Water	15	.12	35.6	17.8	11.8	8.9	7.1	5.9	4.5	3.6
	20	.14	41.6	20.8	13.8	10.4	8.3	6.9	5.2	4.2
	30	.17	50.4	25.2	16.8	12.6	10.1	8.4	6.3	5.0
	40	.20	59.6	29.8	19.8	14.9	11.9	9.9	7.4	5.9
Gallons Per 1000 Sq. Ft. Based on Water	15	.12		.41	.27	.20	.16			
	20	.14		.48	.32	.24	.19			
	30	.17		.58	.39	.29	.23			
	40	.20		.68	.45	.34	.27			

Speed Chart			
Speed in M.P.H. (Miles Per Hour)	Time Required in seconds to travel a distance of		
	100 Ft.	200 Ft.	300 Ft.
1.0	68 sec.	136	205
2.0	34	68	102
3.0	23	45	68
4.0	17	34	51
5.0	14	27	41
6.0	11	23	34
7.0	9.7	19	29
8.0	8.5	17	26
9.0	7.6	15	23
10.0	6.8	14	20

## Tank Care & Maintenance

**Warning:** Do not use the tank as a container for fuel oils, kerosene, gasoline or any other petroleum distillate product. All polyolefins are softened and permeated by such products. In an enclosed area the vaporization of these materials from the outside surface of the tank could create a dangerous condition.

The tank should not be used as a pressure vessel nor used with chemicals or solutions having a weight of more than 12 pounds per gallon.

Store the tank in a dry dark place when not in use. Storage out of sunlight will prolong the life of the tank.

Do not drop, strike or kick the tank, especially at low temperatures. Tanks become brittle and are subject to cracking at temperatures below 20° Fahrenheit.

Always flush the tank with water and a neutralizing agent at the end of each use, to prevent contamination of solutions.

## Maintenance During/After Spraying

Periodically check the strainer and clean the screen on your intake line.

If sprayer becomes clogged during use, discontinue use immediately. DO NOT attempt to service while chemicals are in the sprayer and power is connected.

Proper care and maintenance will prolong the life of your sprayer.

After use, drain the tank and store or dispose of chemical properly. Never allow chemical to sit in the sprayer or pump for long periods of time. Fill the sprayer half way with clean water. Start the pump and allow the water to pump through the entire plumbing system and nozzles. Drain and then refill half full, add the recommended amount of a good quality tank cleaner, such as FIMCO Tank Neutralizer and Cleaner. (If no tank cleaner is available, you may substitute dish soap for this step, about 1-2 oz. per gallon). But a neutralizer/cleaner should be used to thoroughly clean the system.

Turn pump on and circulate through system for 15 minutes and then spray out through boom and handgun nozzles.

Refill sprayer half way with clean water and repeat. Follow the chemical manufacturer's disposal instructions of all wash or rinsing water.

If boom or handgun nozzles need cleaning, remove them from the sprayer and soak in warm soapy water. Clean with a soft bristled brush or toothpick if necessary. Never use a metal object. Even the slightest damage can change the flow rate and spray distribution. Water rinse and dry the tips before storing.



**WARNING:** Some chemicals will damage the pump valves if allowed to soak untreated for a length of time! ALWAYS flush the pump as instructed after each use. DO NOT allow chemicals to sit in the pump for extended times of idleness. Follow the chemical manufacturer's instructions on disposal of all waste water from the sprayer.

### **Storing Sprayer**

When sprayer is not in use, release Cam Lock Handles. This is to prevent deforming of Cam Lock Mechanism. Do not use QR bracket Cams to hold and store boom in vertical position.

### **Winter Storage**

Prepare the sprayer for end-of-season storage by running RV antifreeze through the system. This will keep internal parts lubricated, protect against corrosion and keep the unit from freezing. *Note: RV antifreeze is non-toxic and biodegradable and generally safer for the environment than automotive antifreeze.*

Before storing your sprayer for winter or long term storage, thoroughly clean and drain it as much as possible. Then pour enough pink RV antifreeze into the tank so that when the pump is turned on you can pump the antifreeze throughout the entire plumbing system, including the bypass. Make sure to operate the boom and handgun until you see pink fluid spraying from the nozzles. Leave any remaining antifreeze in the tank. Before your next usage, rinse the antifreeze from the sprayer with clean water. It is nearly impossible to drain all of the water from the sprayer and any trapped water can freeze in cold weather and damage parts of the sprayer. Pumping the antifreeze through the system will displace the water and help prevent this damage.

Removing from storage: drain the antifreeze. Fill the tank with fresh water and run through the system. Dispose of antifreeze and flush water properly.

# HIGHFLO HIGH PERFORMANCE

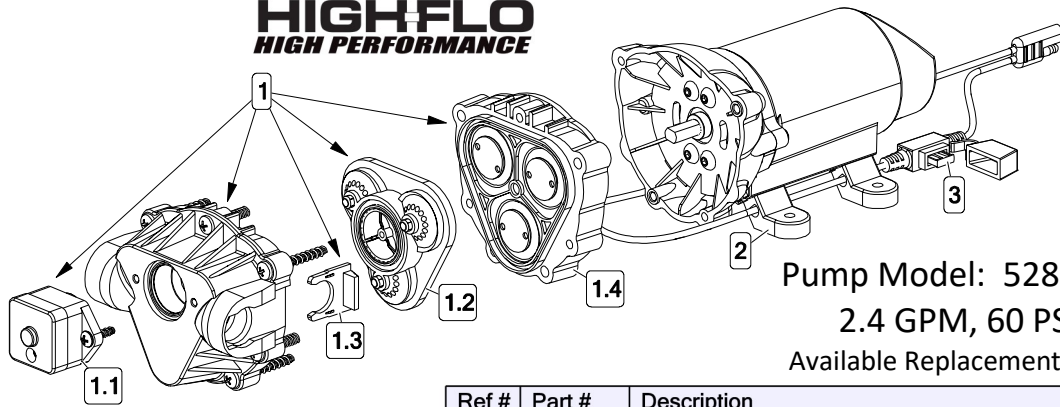

**Pump Model: 5281371**  
**2.4 GPM, 60 PSI**  
 Available Replacement Parts

## Replacement Pump: 5151087

- Includes:
- 3/8" Hose Barb Port Kit Fitting #5168836
  - 1/2" Hose Barb Port Kit Fitting #5168833
  - 1/2" MNPT Port Kit Fitting #5168832

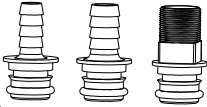

Ref #	Part #	Description	Qty
1	5164273	2.4 GPM Upper Housing	1
1.1	5157202	60 PSI Pressure Switch Assembly	1
1.2	5143544	Check Valve Assembly	1
1.3	5051162	Pump Slide Clips (Pkg/2)	1
1.4	5063270	2.4 GPM Diaphragm /Piston/Cam/Bearing Kit	1
2	5095202	Pump Mount Feet (4 Pack)	1
3	5164274	10 Amp 'Mini Blade' Fuse	1



- Clean and rinse your pump after each use with Fimco Tank Neutralizer.
- Winterize your pump or sprayer by rinsing, draining and running RV Antifreeze through it before storing for the winter.
- Use clean water for your spray mixture.
- Store inside a building when not in use.



- Use to pump bleach.
- Use to pump petroleum products such as diesel fuel, gasoline or kerosene.
- Use to pump chemicals w/petroleum distillates or surfactants.
- Leave your pump sit with spray mixture in it for extended periods.
- Use dirty or unfiltered water for spraying.

**CAUTION**

**PRESSURE SWITCH OPERATION**

Pressure switch is pre-set at the factory. Improper adjustment of the pressure, may cause severe overload or premature failure. If pump is subjected to rapid cycling during normal operations or infrequent periods, damage may occur.

**WARNING**

DO NOT USE PUMP IN AN EXPLOSIVE ENVIRONMENT.  
DO NOT USE TO PUMP FLAMMABLE/COMBUSTIBLE FLUIDS, GASOLINE, KEROSENE, FUEL, OIL, ETC.

## Troubleshooting

Pump will not run:	<ul style="list-style-type: none"> <li>Check for loose wiring</li> <li>Check the fuse</li> <li>Check for defective pressure switch</li> <li>Check for Low Voltage</li> </ul>	Low flow may cause pump to surge
Pump Does Not Prime (No Discharge w/Motor Running)	<ul style="list-style-type: none"> <li>Check for clogged strainer/filter</li> <li>Check for kinked inlet/outlet hoses</li> <li>Check for empty product supply</li> <li>Check for defective check valve</li> <li>Check for debris in the check valve assembly</li> <li>Check for cracks in the pump housing</li> <li>Check for air leaks in supply line</li> </ul>	<ul style="list-style-type: none"> <li>Spray Wand is adjusted to small or fine of a spray pattern</li> <li>Check for defective pressure switch</li> <li>Check for leaks in the discharge line</li> <li>Check for debris in nozzle orifice</li> <li>Discharge hose may be too long</li> <li>Check for clogged strainer/filter</li> <li>Check for worn or dirty check valve</li> <li>Slightly open bypass (if applicable) to overcome</li> <li>Pressure switch may need to be adjusted</li> <li>1/4 turn at a time clockwise until surging stops</li> </ul>
Low Pressure/ Low Flow:	<ul style="list-style-type: none"> <li>Check for proper voltage</li> <li>Check for leaks in the discharge line</li> <li>Check for restrictions in the discharge line</li> <li>Check for debris in intake</li> <li>Check for debris in nozzle orifice</li> <li>Check for worn or dirty check valve</li> </ul>	Pump continues to run:
Fuse blows:	<ul style="list-style-type: none"> <li>Improper adjustment of pressure switch</li> <li>Damaged or defective wiring</li> <li>Defective pressure switch</li> </ul>	<ul style="list-style-type: none"> <li>Check for worn or dirty check valve</li> <li>Check for empty product supply</li> <li>Check for Low Voltage</li> <li>Check for leaks in the discharge line</li> <li>Check for defective pressure switch</li> <li>System has leaks</li> <li>Air trapped in outlet line or pump head</li> </ul>

### Before Troubleshooting or Attempting to Service the Pump:

- ◆ **Review Troubleshooting Chart:** Do Not attempt to repair until steps below are followed.
- ◆ **Personal Protective Gear:** Wear protective gear when servicing pump.
- ◆ **Disconnect Power:** Disconnect the power to the pump and relieve the pressure from the system.
- ◆ **Empty and Flush** the pump system with water, never attempt to service the pump until it has been emptied and flushed.
- ◆ **Perform Repairs:** Follow directions provided in the troubleshooting section to repair the pump.
- ◆ **Test:** Always test the pump for leaks with plain water after any repairs before using.

#### Motor is NOT Running - Checking the Pressure Switch:

If motor is not running and you've checked the following: for loose wiring connections, fuse, switch on lead wire was "ON" and made sure you were connected to a fully charged battery but the motor won't run, then it's time to check to see if the pressure switch is bad.

- Remove the cover off the 1" square box (pressure switch) on the head of the pump, the cover is held on by one phillips-head screw. This will expose the two red wires.
- With the pump connected to a good 12 volt power source and everything on.
- Slip the two red wires off the terminals and touch them together.
- ◆ If motor runs, it means the pressure switch is bad and needs to be replaced.
- ◆ If motor still doesn't run, try bypassing the switch in the lead wire or using another lead wire. Even if a tester shows power to the pressure switch, still try this test.

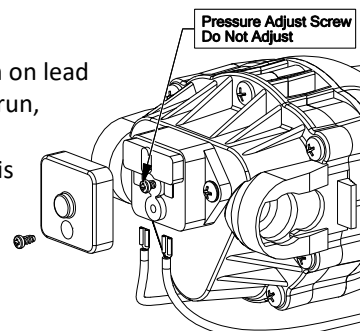

**Warning:** It is NOT recommended to run the pump this way, as the pump will continue to run and not shut off.

This could result in blown hoses when all discharges are closed or premature failure of the pump completely.

#### Motor Running-No Pressure - - Cleaning the Check Valve:

Experiencing little to no pressure or pump is not priming and filter screen is clean and plumbing is good with no leaks, you may need to clean the check valve.

- Remove the head of the pump, which is held on by 7 screws.
- First part inside the head of the pump is the check valve, this part responsible for building up pressure and pumping water/solution through the lines.
- Clean the check valve under hot, soapy water (such as a good grade dish soap).
- Lightly scrub, if needed, with something like an old toothbrush, something with soft bristles.
- Let soak for about an hour or so in the hot soapy solution, replace in the pump and reassemble.

Most times this will restore most, if not all of the prime of a pump.

If still having issues with pressure after this step, it would be recommended to replace this part.

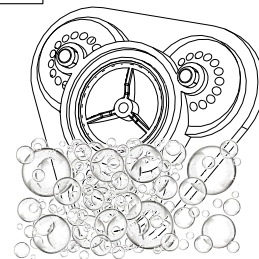
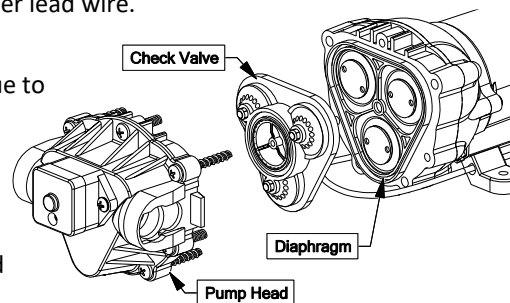

### Intake/Siphon Tube/Screen Detail of a Typical L&G/ATV Sprayer (not including the 'EC' Units)

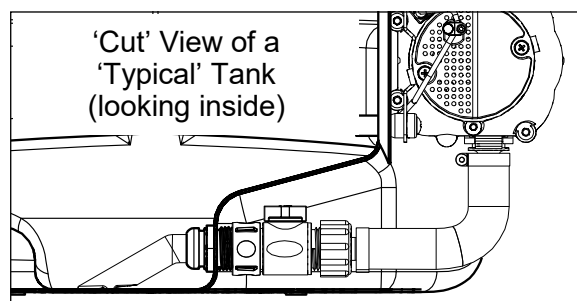
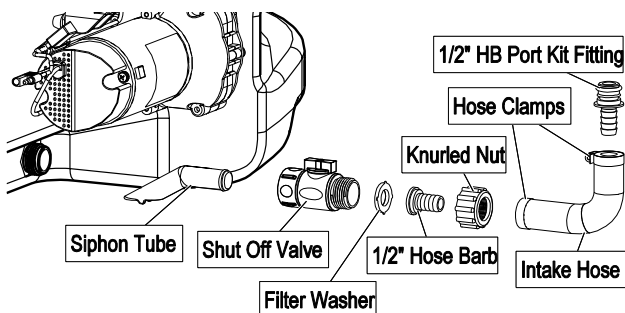

The suction line of sprayer should contain a 'siphon tube' or intake tube which should be rotated so that it just touches the bottom of the tank surface. (see Detail). Reach in and rotate it, as needed, if not already in this position.

A shut-off valve is threaded onto the pipe nipple at the intake location on the tank. It is at this location so you can shut off the flow of solution to access your system's screen for cleaning.

#### Checking/Cleaning the sprayer's filter/screen:

- ◆ Start your pump and before it shuts off, reach down and shut the valve to the 'Closed' position (lever is perpendicular to the flow of fluid), then shut off your pump.
- ◆ Unscrew the knurled nut from the shut-off valve, leaving the valve connected to the tank.
- ◆ Swivel intake assembly towards you. Look in the nut you JUST unscrewed. Screen/washer is located there.
- ◆ Remove screen and clean as necessary. Replace when done and reassemble the entire assembly.
- ◆ Make sure the valve is turned to the 'Open' position before restarting your pump.

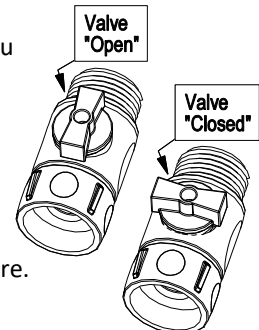

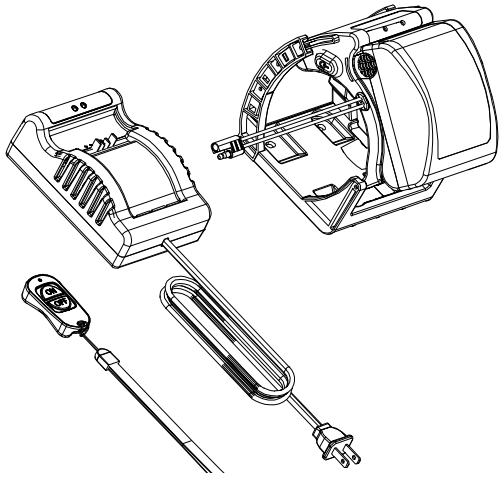

## 20V, 5A Lithium Battery Kit (5281506)

### Instruction Manual for Volt Edge 20V max\* Li-ion Battery Charger

\* Maximum initial battery pack voltage (measured without a workload) is 20 volts. Measured under workload, nominal voltage is 18 volts.

The label on your product may include the following symbols.

V volts

A Amperes

Hz Hertz

Ah Amp hours

— Direct Current



Safety Alert Symbol

Wh Watt Hours

~ Alternating Current



Read Owner's Manual



Recycle Battery

### Important Safety Instructions - Save These Instructions.

This manual contains important safety instructions for the components.

**Warning:** Before using, read and follow all instructions and cautionary markings on charger, battery pack and product using battery pack.

**Warning:** To reduce the risk of injury, basic safety precautions should always be followed including:

- Do not incinerate the battery pack, even if it is severely damaged or is completely worn out. The battery pack can explode in a fire. Toxic fumes and materials are created when the battery packs are burned.
- Do not charge or use battery in explosive atmospheres, such as in the presence of flammable liquids, gases or dust. Inserting or removing the battery from the charger may ignite the dust or fumes.
- If battery contents come into contact with the skin, immediately wash area with mild soap and water. If battery liquid gets into the eye, rinse water over the open eye for 15 minutes or until irritation ceases.
- Contents of opened battery cells may cause respiratory irritation. Provide fresh air. If symptoms persist, seek medical attention.

**Warning:** To reduce the risk of injury, basic safety precautions should always be followed including:

- Charge battery packs only in Volt Edge 20V max Lithium-ion compatible chargers.
- Do not store or charge battery pack in locations where the temperature may reach above 95°F (35°C) or below 40°F (4°C).
- Do not use the battery pack in locations where the temperature may reach above 120°F (49°C) or below -4°F (-20°C).

### Warning:

Never attempt to open the battery pack for any reason. If the battery pack case is cracked or damaged, do not insert into charger or other Volt Edge products. Do not crush, drop or damage battery pack. Do not use battery pack or charger that has received a sharp blow, been dropped, run over or damaged in any way. Damaged battery packs should be taken to a lithium battery recycling center.

### Warning:

Fire hazard. Do not store or carry battery so that metal objects can contact exposed battery terminals. Transporting batteries can possibly cause fires, if the battery terminals inadvertently come in contact with conductive materials.

### Warning:

Shock hazard. Do not allow any liquid to get inside charger.

**Warning:**

Burn hazard. To reduce the risk of injury, charge only designated Volt Edge 20Vmax batteries. Other types of batteries may burst, causing personal injury and damage.

**Caution:**

Under certain conditions, with the charger plugged into the power supply, the charger can be shorted by foreign material. Foreign materials of a conductive nature, such as, but not limited to, steel wool, aluminum foil or any buildup of metallic particles should be kept away from charger cavities. Always unplug the charger from the power supply when there is no battery pack in the cavity. Unplug charger before attempting to clean.

**Warning:**

- Do not attempt to charge the battery pack with any chargers, other than the ones in this manual. The charger and battery pack are specifically designed to work together.
- The chargers are not intended for any uses other than charging designated Volt Edge 20Vmax Lithium-ion batteries. Any other uses may result in risk of fire, electric shock or electrocution.
- Be sure voltage selector is in correct voltage position before plugging in.
- For use in the U.S.A., the voltage selector switch must be placed in the 120 volt position. For use in countries, other than the U.S.A., the voltage selector may need to be placed in other than the 120 volt position. Confirm the voltage available at each country location before using this product.
- Do not expose charger to rain or snow.
- Pull by plug, rather than cord when disconnecting charger. This will reduce the risk of damage to electric plug and cord.
- If the shape of the plug does not fit the power outlet, use an attachment plug adaptor of the proper configuration for the power outlet.
- Make sure that cord is located so that it will not be stepped on, tripped over or otherwise subjected to damage or stress.
- Do not use an extension cord, unless it is necessary. Use of improper extension cord could result in risk of fire, electric shock or electrocution.
- Do not operate charger with damaged cord or plug.
- Do not operate charger if it has received a sharp blow, been dropped or otherwise damaged in any way.
- Do not disassemble the charger.
- Disconnect the charger from the outlet before attempting any cleaning. This will reduce the risk of electric shock. Removing the battery pack will not reduce this risk.
- The charger is designed to operate on standard household electric power (120V). Do not attempt to use it on any other voltage.
- The power unit is intended to be correctly oriented in a vertical or floor mount position.

**Declaration of Conformity:**

This device complies with Part 15 of the FCC Rules. Operation is subject to the following two conditions:

- 1) This device may not cause harmful interference.
- 2) This device must accept any interference received, including interference that may cause undesired operation.

This device complies with:

- Appendix Y to Subpart B of Part 430-Uniform Test Method for Measuring the Energy Consumption of Battery Chargers. DOE energy conservation standards specified in the Code of Federal Regulations at 10 CFR 430.32(z).
- This device complies with CEC, Section 1605.1(w) of energy efficiency standards for federally regulated battery chargers of California Code of Regulations.
- This device complies with NRCAN(EEV), CSA-C381.2-17 May 2017 and Canada's Energy Efficiency Regulations.
- This device complies with cETLus certification based on Conforms to UL STD.1310 Certified to CSA STD.CC22 NO.223.

**Storage Recommendations:**

- The best storage place is one that is cool and dry, away from direct sunlight and excess heat or cold.
- Long storage will not harm the battery pack or charger.
- Do not store a battery connected to a charger.

**Charging Instructions:**

The battery pack is not fully charged out of the carton. Before using the battery pack and charger, read the safety instructions below. Then follow charging procedure.

## Charging Procedure

1. Plug the charger into an appropriate outlet before inserting the battery pack. The green LED will flash once indicating the charger is ready to use.
2. Insert the battery pack into the charger.
3. The green LED will flash indicating the battery is being charged.



4. The completion of charger is indicated by the green LED remaining on continuously. The pack is fully charged and may be used at this time or left on the charger.
  - a. Recharge discharged batteries as soon as possible after use or battery life may be greatly diminished. For longest battery life, do not discharge batteries fully. It is recommended that the batteries be recharged after each use.



5. If the battery remains on the charger for more than 2 hours after charging is complete, the green LED will slowly blink.



## Charger Diagnostics

This charger is designed to detect certain problems that can arise with the battery packs or the power source. Problems are indicated by the red and green LEDs.



### Temperature Delay

When the charger detects a battery that is excessively hot or excessively cold, it automatically starts a Temperature Delay, suspending charging until the battery temperature returns to acceptable temperatures. The red LED will flash indicating the battery is outside the required temperature range and not charging. Once the temperature is within the required range, charging will begin.



### Broken Battery

The charger can detect a weak or damaged battery. The red and green LED will alternate flashing. If you see this warning, do not continue to charge the battery and remove the battery from the charger.

## Leaving the battery in the charger.

The charger and battery pack can be left connected with the green LED indicating the charger is maintaining the battery continuously. The charger will keep the battery pack fresh and fully charged.

## Important charging notes:

1. Longest life and best performance can be obtained if the battery pack is charged with the air temperature is between 50°F (10°C) and 80°F (26°C).
2. The charger and battery pack may become warm to the touch while charging. This is normal and does not indicate a problem. Ensure the vents are not blocked to allow cooling.
3. The battery pack should be recharged when it no longer powers the equipment. Do not continue to attempt using the battery if low power is indicated. You may recharge a partially discharged battery pack without damaging battery pack.
4. Do not freeze or submerge the charger in water or any other liquid.

## Warning:

Shock Hazard. Do not allow any liquid to get inside the charger. Never attempt to open the battery pack for any reason. If the plastic housing of the battery pack breaks for cracks, return to a recycling center and replace the charger.

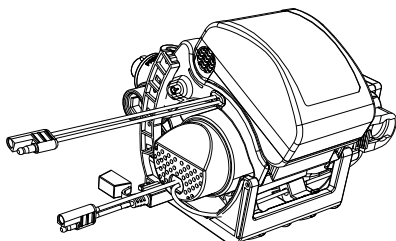

Receiver is designed to power all High-Flo 12V pumps. Receiver will output 12V DC and is limited to 15A max. current.

To install the receiver, the pump will be removed. The base plate and adjustable support will be placed under the pump and screwed down with the longer screws supplied in the kit. The receiver has already been pinned to the base plate, but it can be removed to make screw installation easier by sliding the pin out. Then the receiver is slid into the adjustable support bracket. It will click into the first position, sized for the Pro Series pumps and the 4.5 pump.

## 2.4 GPM Pump w/Manifold Configuration:

Place pump on base plate and screw down to tank or frame, using the (3) #10-24 x 3/4" and (1) #10-24 x 1" screws. The 1" screw goes through the manifold support bracket. Click the receiver into the second position of the adjustable support.

## Operating Procedure:



1. Charge the battery following the charging procedure.
2. Ensure all fasteners are tight and pump connections are secure.
3. Install the battery ensuring the base is connected and it is fully seated.
4. Press the power button and confirm the green LED turns on. Signaling the power is on.
5. Test the remote by pressing the OFF button on the remote and both green and red receiver LEDs will turn on. Signaling the power output is off while the power is on.
6. Press the ON button on the remote. The red LED will turn off and power output will return.
7. Press the power button again to turn the receiver off.
8. Connect the receiver 2-pin connector to the pump.
9. Press the power button to turn the receiver on and the pump will run.
10. When spraying is complete press the power button to turn off the receiver.
11. Recharge the battery to properly maintain the battery pack.

## Receiver Diagnostics:

The receiver is designed to detect certain problems that can arise with the battery packs or the pump. Problems are indicated by the red and green LEDs.



### Battery Life



When the battery is approaching fully discharged, the green LED will begin to flash. When the battery is fully discharged, power will stop being supplied to the pump and the green LED will continue flashing. Power off the receiver and charge the battery.



### Protection Mode



When the receiver identifies a problem with the pump, the power output will stop and the red LED will flash and the green LED will remain illuminated. The red LED will blink in cycles to identify the problem. Press the power button turning the receiver off to reset the system. Wait 30 seconds and press the power button to resume operation.

Red LED flashing two times: Open circuit protection. The receiver power is on without powering consumption.

Red LED flashing three times: Incorrect voltage. Voltage being supplied to the receiver is outside the range.

Red LED flashing four times: High current protection. The pump has drawn current above the limit.

Red LED flashing ten times: Temperature protection. The system has measured the temperature to be outside safe operating temperatures.

## Remote Button Identification:

The small LED at the top of remote turns red when transmitting.

The red LED is also the pairing button.

The 'ON' button will only turn on the Volt Edge Receiver.

The 'OFF' button will only turn off the Volt Edge Receiver.

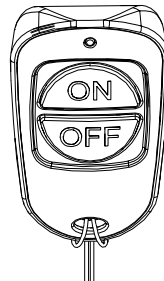

## Pairing Procedure:

1. Ensure the receiver power cord is not connected.
2. Install a charged battery pack into the receiver.
3. Power ON the Volt Edge receiver. Within 15 seconds press and hold the pairing button for 5 seconds. The green LED on the receiver will quickly turn off and back on when pairing is successful.
4. Power OFF the Volt Edge receiver.
5. Power ON the Volt Edge receiver and press the OFF and then ON button to confirm pairing is successful.

**Storage Recommendations:**

- The best storage place is one that is cool and dry, away from direct sunlight and excess heat, cold or moisture.

**Remote Capabilities:**

- The remote can control the receiver up to 50 feet away. Obstructions and radio interference can reduce the effective distance.
- A remote can be paired to multiple receivers at one time.
- A receiver can only be paired to one remote at a time.
- A receiver/remote relationship can only be separated by pairing with another remote.

**FCC WARNING:**

Please note that changes or modifications of this product is not expressly approved by the party responsible for compliance, could void the user's authority to operate the equipment.

**FCC STATEMENT:**

NOTE: This equipment has been tested and found to comply with the limits for a Class B digital device, pursuant to Part 15 of the FCC Rules. These limits are designed to provide reasonable protection against harmful interference in a residential installation. This equipment generates, uses and can radiate radio frequency energy and, if not installed and used in accordance with the instructions, may cause harmful interference to radio communications.

However, there is no guarantee that interference will not occur in a particular installation. If this equipment does cause harmful interference to radio or television reception, which can be determined by turning the equipment off and on, the user is encouraged to try to correct the interference by one or more of the following measures:

- ◇ Reorient or relocate the receiving antenna.
- ◇ Increase the separation between the equipment and receiver.
- ◇ Connect the equipment into an outlet on a circuit different from that to which the receiver is connected.
- ◇ Consult the dealer or an experienced radio/TV technician for help.

**Declaration of Conformity:**

This device complies with Part 15 of the FCC Rules. Operation is subject to the following two conditions:

- 1) This device may not cause harmful interference.
- 2) This device must accept any interference received, including interference that may cause undesired operation.



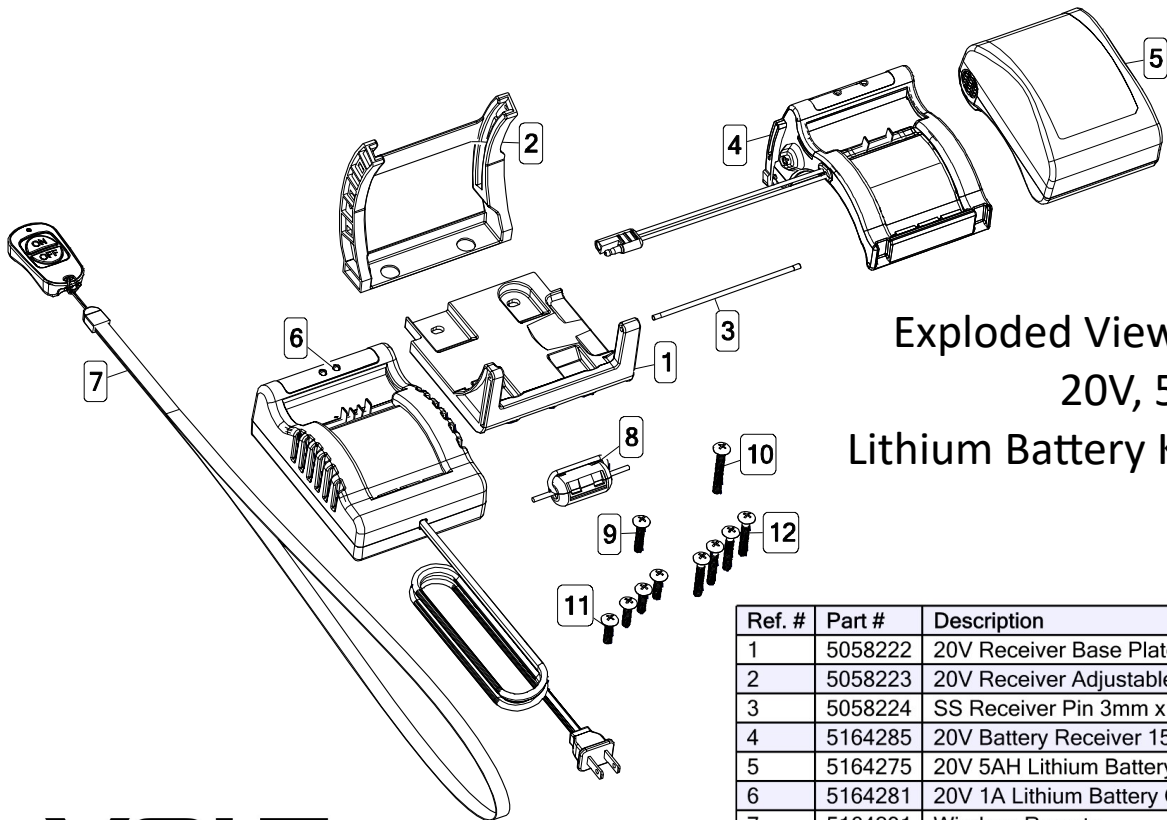

## Exploded View/Parts List 20V, 5A Lithium Battery Kit (5281506)

Ref. #	Part #	Description	Qty
1	5058222	20V Receiver Base Plate	1
2	5058223	20V Receiver Adjustable Support	1
3	5058224	SS Receiver Pin 3mm x 110mm	1
4	5164285	20V Battery Receiver 15A	1
5	5164275	20V 5AH Lithium Battery Pack	1
6	5164281	20V 1A Lithium Battery Charger	1
7	5164291	Wireless Remote	1
8	5051173	Clamp On Ferrite Ring	1
9	5117168	#10-24 x 1" PH Truss Head Mach. Screw	1
10	5117338	#10-24 x 1 1/2" PH Truss Head Mach. Screw	1
11	5117176	#10-24 x 3/4" PH Truss Head Mach. Screw	4
12	5117166	#10-24 x 1 1/4" PH Truss Head Mach. Screw	4



## TROUBLESHOOTING

Problem	Possible Cause	Possible Solution
Battery will not charge	Charger not plugged in	Plug charger into a working outlet. Check outlet with another device.
	Temperature is too hot or too cold	Move charger and battery to a climate-controlled environment and wait for the product to reach room temperature.
	Battery pack not inserted into charger	Remove battery pack and re-install battery pack. Ensure the bottom edge of the battery is seated first, then push the clips in.
Remote does not control the receiver	Remote battery is discharged	Replace the battery with CR2032 size button cell battery.
	Receiver is not on	The green light must be illuminated on the receiver for the remote to control it.
	Remote is not paired with receiver	Follow the Pairing Instructions to pair a remote and receiver.
	Radio Interference	Move the receiver and remote away from the electronic interference.
Receiver does not power pump & green LED is off	Battery not connected	Remove battery pack and carefully reinstall.
	Battery discharged	Remove battery, charge and reinstall.
Receiver does not power pump & green LED is on	Bad electrical connection	Follow wires from receiver to plug. Disconnect and reconnect 2-pin plug.
	Pump fuse is blown	Check fuse on pump wire and replace if necessary.

# Exploded View/Parts List 20V-25-700-ATV (5303076)

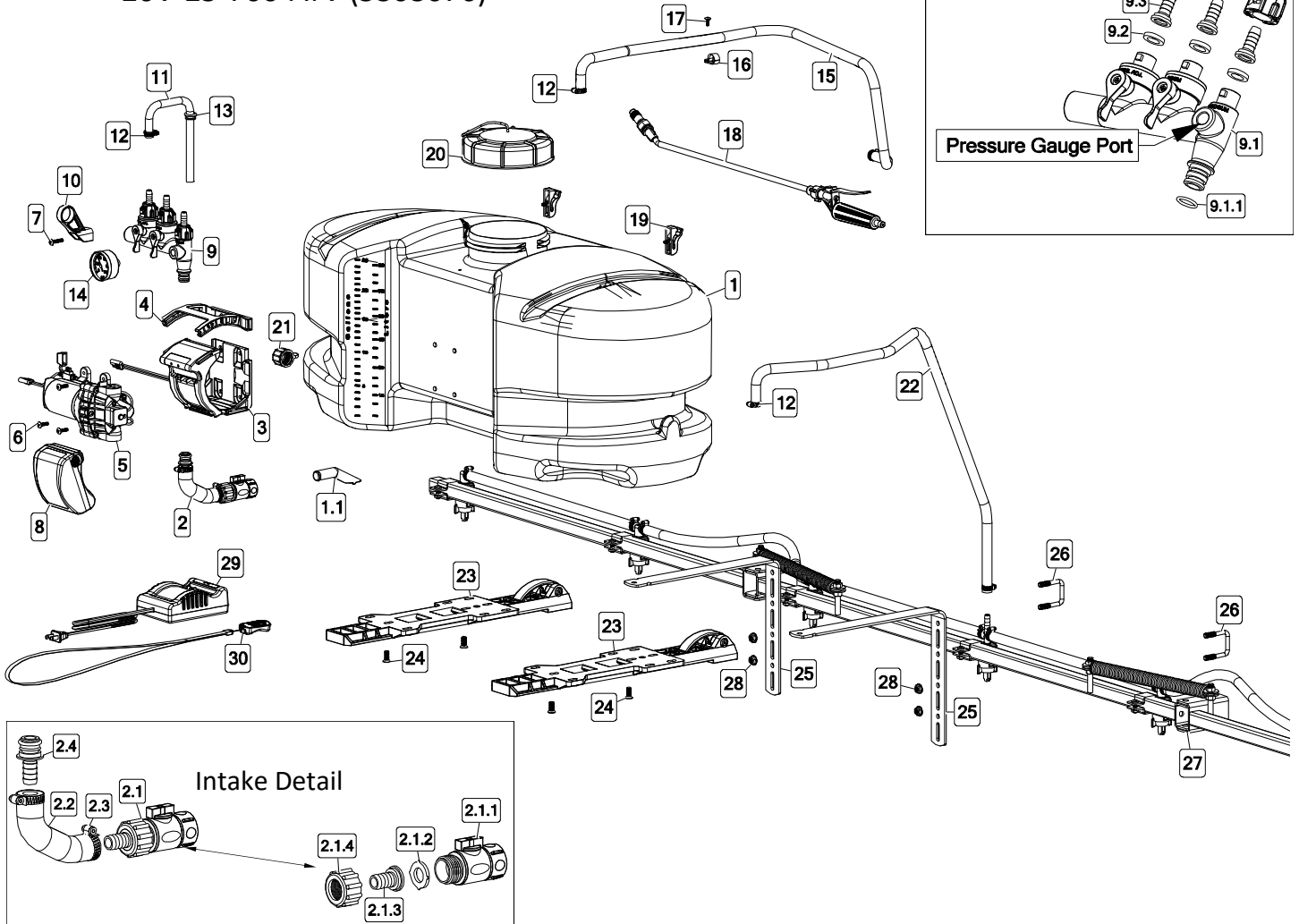

Ref. #	Part #	Description	Qty
1	5169243	25 Gallon Tank (White)	1
1.1	5100452	Siphon Tube	1
2	5281145	Intake Shut-Off Assembly	1
2.1	5282416	Intake Shutoff Subassembly	1
2.1.1	5143419	Swivel Shut-Off	1
2.1.2	5116242	Strainer, 1" Filter Washer	1
2.1.3	5149035	Poly Swivel, 1/2" Hose Barb	1
2.1.4	5006209	Poly Knurled Swivel Nut, 3/4" FGHT	1
2.2	5020583	1/2" Polyspring Hose x 4 1/4" Long	1
2.3	5051114	Hose Clamp (1/2")	2
2.4	5168833	Port Kit Fitting, 1/2" Hose Barb	1
3	5281510	20V Receiver Sub Assembly	1
3.1	5058222	20V Receiver Base Plate	1
3.2	5058224	SS Receiver Pin 3mm x 108mm	1
3.3	5164285	20V Battery Receiver 15A	1
4	5058223	20V Receiver Adjustable Support	1
5	5281371	2.4 GPM Pump, 60 PSI	1
6	5117176	#10-24 x 0.75 PH Truss Head Screw	3
7	5117168	#10-24 x 1.00 PH Truss Head Screw	1
8	5164275	20V 5AH Lithium Battery Pack	1
9	5281538	Quick Connect Manifold Assembly	1
9.1	5302347	Quick Connect Manifold (Main Body)	1
9.1.1	5072514	O-Ring - Pump Port Connection	1
9.2	5143430	Flat Washer - Hose Barb Seal	3
9.3	5143431	QC Manifold - 3/8" Hose Straight Barb	3
9.4	5143429	Quick Connect Quarter Turn Cap	3

Ref. #	Part #	Description	Qty
10	5143422	QC Manifold - Support Bracket	1
11	5100959	Formed Bypass Tube	1
12	5051144	Hose Clamp (3/8")	5
13	5075018	Grommet, 1/2" ID	1
14	5167097	2" Dry 100# Back Mount Pressure Gauge	1
15	5020524	Hose, 3/8"-1 Brd. x 15 Ft.	1
16	5051122	5/8" Black Nylon Loom Cable Clamp	1
17	5117234	#10-24 x 1/2" PH Round Head Screw	1
18	5163100	Low-Flow Spray Wand w/X-26 Tip	1
18.1	5018330	Handgun Tip (X-26)	1
19	5274880	Handgun Clips & Screws (Pkg/2)	1
20	5058188	Tank Lid w/Lanyard	1
20.1	5058189	5" Lid (NO Lanyard)	1
20.2	5058170	Tank Lid Lanyard, 8" (Black)	1
21	5274373	Drain Plug Assembly	1
22	5020161	Hose, 3/8"-1 Brd. x 48"	1
23	5278222	ATV Quick Release Bracket	2
24	5034149	5/16-18 x 0.75 PH Flat Head Screw	4
25	5038872-BLK	QR Bracket - Bent Adjustable Height	2
26	5034159	5/16-18 x 1.3125 x 1.875 Square U-Bolt	2
27	5301897	Generic 7-Nozzle Boom Assembly	1
28	5006307	5/16-18 Serrated Flange Hex Nut	4
29	5164281	20V 1A Lithium Battery Charger	1
30	5164291	Wireless Remote	1

# 7-Nozzle Boom Assembly (5301897)

(with 3/8" Hose, 1" Sq. Tubing & AIXR11002VP Tips)

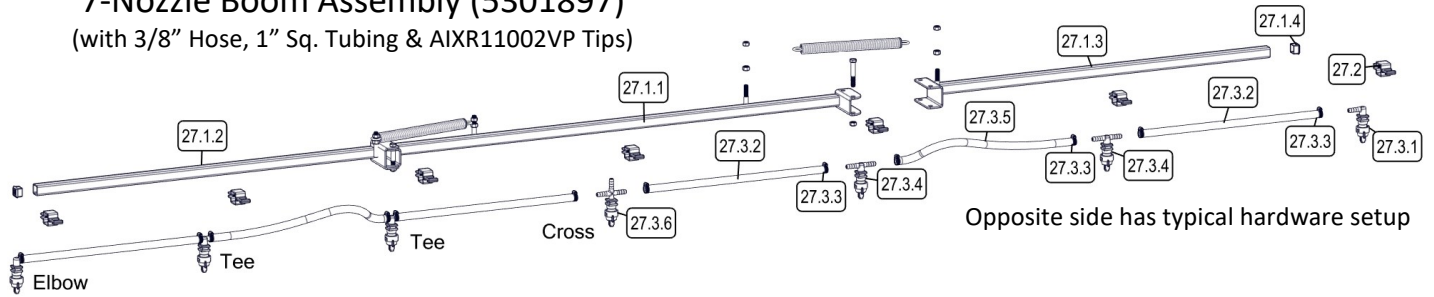

Opposite side has typical hardware setup

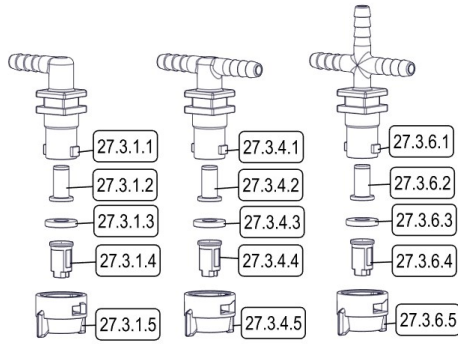

ELL

TEE

CROSS

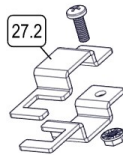

Clamp  
Bag of 7:  
5277730

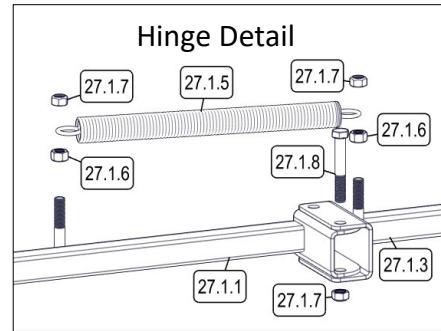

### Hinge Detail

Ref. #	Part #	Description	Qty
27	5301897	7-Nozzle Boom Assembly	1
27.1	5277780	7-Nozzle Boom	1
27.1.1	5277838-BLK	Center Boom Weldment 1" Sq. Tube	1
27.1.2	5277837-BLK	Outer Boom Weldment (LH) (1" Sq Tube)	1
27.1.3	5277836-BLK	Outer Boom Weldment (RH) (1" Sq Tube)	1
27.1.4	5046106	Square Cap, Black (1" Square Tube)	2
27.1.5	5019228	Extension Spring	2
27.1.6	5006259	3/8"-16 Flange Hex Whiz Locknut	4
27.1.7	5006345	3/8"-16 Flange Locknut	6
27.1.8	5034169	H.H.C.S., 3/8"-16 x 2 1/2"	2
27.2	5277923	Nozzle Clamp (1" Sq. Tube)	7
27.3	5277696	7-Nozzle Harness (3/8")	1
27.3.1	5281304	"ELL" Nozzle Sub-Assembly (3/8")	2
27.3.1.1	5056113	Single Hose Shank (3/8" Hose)	1
27.3.1.2	5143543	Check Valve Strainer, 50 Mesh, 5 PSI	1
27.3.1.3	5016157	Seat Washer (QJ Caps)	1
27.3.1.4	5018371	Air-Induction XR Flat Spray Tip (AIXR11002VP)	1

Ref. #	Part #	Description	Qty
27.3.1.5	5046219	Quick TeeJet Cap ONLY (Yellow)	1
27.3.2	5020510	Hose, 3/8"-1 Brd. x 19-3/8"	4
27.3.3	5051144	Hose Clamp, 3/8"	12
27.3.4	5281307	"TEE" Nozzle Sub-Assembly (3/8")	4
27.3.4.1	5056114	Double Hose Shank (3/8" Hose)	1
27.3.4.2	5143543	Check Valve Strainer, 50 Mesh, 5 PSI	1
27.3.4.3	5016157	Seat Washer (QJ Caps)	1
27.3.4.4	5018371	Air-Induction XR Flat Spray Tip (AIXR11002VP)	1
27.3.4.5	5046219	Quick TeeJet Cap ONLY (Yellow)	1
27.3.5	5020511	Hose, 3/8"-1 Brd. x 21"	2
27.3.6	5281308	"Cross" Nozzle Sub-Assembly (3/8")	1
27.3.6.1	5056115	Triple Hose Shank (3/8" Hose)	1
27.3.6.2	5143543	Check Valve Strainer, 50 Mesh, 5 PSI	1
27.3.6.3	5016157	Seat Washer (QJ Caps)	1
27.3.6.4	5018371	Air-Induction XR Flat Spray Tip (AIXR11002VP)	1
27.3.6.5	5046219	Quick TeeJet Cap ONLY (Yellow)	1

- 110° wide, tapered flat spray angle with air induction technology for better drift management
- Made of 2-piece UHMWPE polymer construction which provides excellent chemical resistance, including acids, as well as exceptional wear life
- Compact size to prevent tip damage
- Excellent for systemic products and drift management

Based on the minimum overlap required to obtain uniform distribution with 110° tips and 20" spacing.  
Suggested Minimum Spray Height: 16"-18" above what is being sprayed (to plant, not ground).  
Optimum Spray Height: 20"

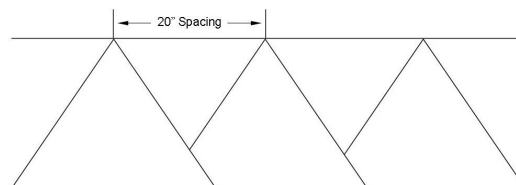
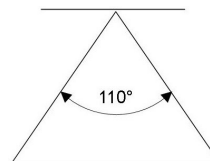

## Dimensions:

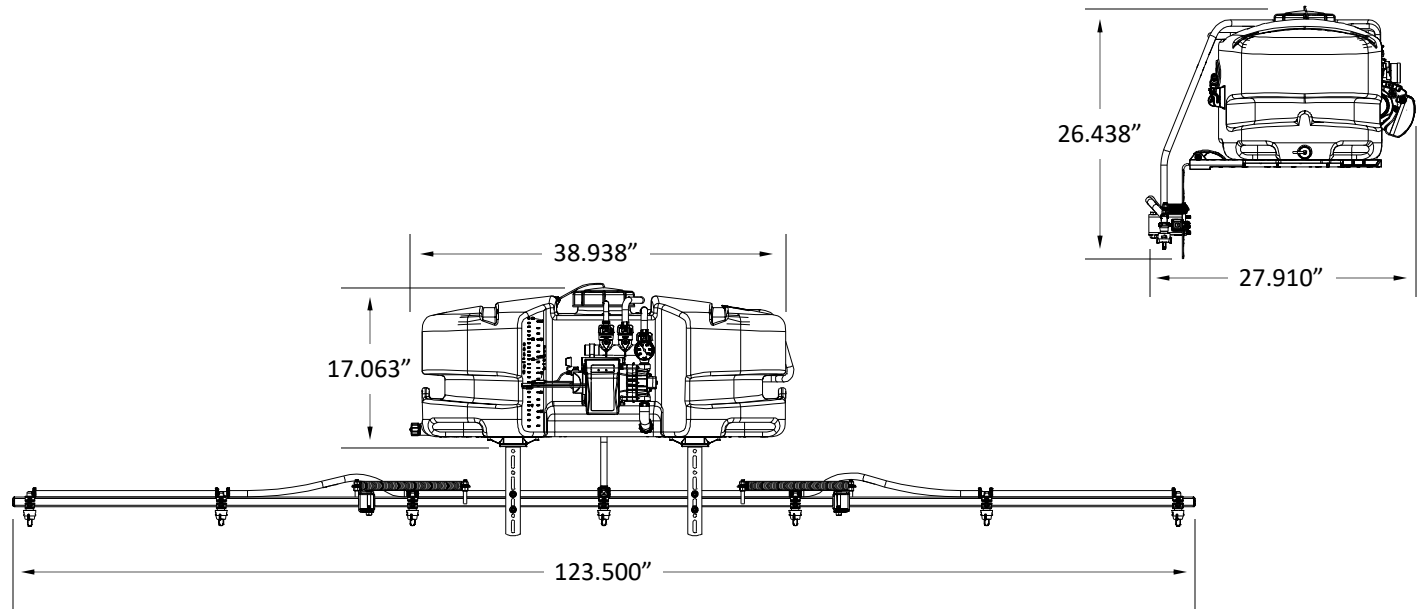

## Warranty

### LIMITED WARRANTY FOR NEW FIMCO, IND. EQUIPMENT

**WHO MAY USE THIS LIMITED WARRANTY.** This limited warranty (the "Limited Warranty") is provided by Fimco, Ind. to the original purchaser ("you") of the Equipment (as defined below) from Fimco, Ind. or one of Fimco, Ind.'s authorized dealers. This Limited Warranty does not apply to any subsequent owner or other transferee of the Equipment. THIS LIMITED WARRANTY GIVES YOU SPECIFIC LEGAL RIGHTS, AND YOU MAY ALSO HAVE OTHER RIGHTS WHICH VARY FROM STATE TO STATE.

**WHAT THIS LIMITED WARRANTY COVERS AND FOR HOW LONG.** Fimco, Ind. warrants that any new Equipment will be free from defects in material and workmanship for a period of **one (1) year** for sprayer and **two (2) years** for High-Flo High Performance pump (homeowner), **90 days** for sprayer and pump (commercial user), after delivery of the Equipment to you (the "Warranty Period"). The Warranty Period is not extended if Fimco, Ind. repairs or replaces the Equipment.

**WHAT IS NOT COVERED BY THIS LIMITED WARRANTY.** This Limited Warranty does not apply to: (1) used Equipment; (2) any Equipment that has been altered, changed, repaired or treated since its delivery to you, other than by Fimco, Ind. or its authorized dealers; (3) damage or depreciation due to normal wear and tear; (4) defects or damage due to failure to follow Fimco, Ind.'s operator's manual, specifications or other written instructions, or improper storage, operation, maintenance, application or installation of parts; (5) defects or damage due to misuse, accident or neglect, "acts of God" or other events beyond Fimco, Ind.'s reasonable control; (6) accessories, attachments, tools or parts that were not manufactured by Fimco, Ind., whether or not sold or operated with the Equipment; or (7) rubber parts, such as tires, hoses and grommets.

**HOW TO OBTAIN WARRANTY SERVICE.** To obtain warranty service under this Limited Warranty, you must (1) provide written notice to Fimco, Ind. of the defect during the Warranty Period and within **thirty (30) days** after the defect becomes apparent or the repair becomes necessary, at the following address: Fimco, Ind., 1000 Fimco Lane, North Sioux City, SD 57049; and (2) make the Equipment available to Fimco, Ind. or an authorized dealer within a reasonable period of time. For more information about this Limited Warranty, please call: **800-831-0027**.

**WHAT REMEDIES ARE AVAILABLE UNDER THIS LIMITED WARRANTY.** If the conditions set forth above are fulfilled and the Equipment or any part thereof is found to be defective, Fimco, Ind. shall, at its own cost, and at its option, either repair or replace the defective Equipment or part. Fimco, Ind. will pay for shipping and handling fees to return the repaired or replacement Equipment or part to you.

**LIMITATION OF IMPLIED WARRANTIES AND OTHER REMEDIES.** THE REMEDIES DESCRIBED ABOVE ARE YOUR SOLE AND EXCLUSIVE REMEDIES, AND FIMCO, IND.'S SOLE LIABILITY, FOR ANY BREACH OF THIS LIMITED WARRANTY. TO THE EXTENT APPLICABLE, ANY IMPLIED WARRANTIES, INCLUDING, WITHOUT LIMITATION, THE IMPLIED WARRANTIES OF MERCHANTABILITY AND FITNESS FOR A PARTICULAR PURPOSE, SHALL BE LIMITED IN DURATION TO THE WARRANTY PERIOD, AND THE REMEDIES AVAILABLE FOR BREACH THEREOF SHALL BE LIMITED TO THE REMEDIES AVAILABLE UNDER THIS EXPRESS LIMITED WARRANTY. SOME STATES DO NOT ALLOW LIMITATIONS ON HOW LONG AN IMPLIED WARRANTY LASTS, SO THE ABOVE LIMITATION MAY NOT APPLY TO YOU. IN NO EVENT SHALL FIMCO, IND.'S LIABILITY UNDER THIS LIMITED WARRANTY EXCEED THE ACTUAL AMOUNT PAID BY YOU FOR THE DEFECTIVE EQUIPMENT, NOR SHALL FIMCO, IND. BE LIABLE, UNDER ANY CIRCUMSTANCES, FOR ANY CONSEQUENTIAL, INCIDENTAL, SPECIAL OR PUNITIVE DAMAGES OR LOSSES, WHETHER DIRECT OR INDIRECT. SOME STATES DO NOT ALLOW THE EXCLUSION OR LIMITATION OF INCIDENTAL OR CONSEQUENTIAL DAMAGES, SO THE ABOVE LIMITATION OR EXCLUSION MAY NOT APPLY TO YOU.