

OWNER'S MANUAL

Model: 9-300 (5300656)

(300 Gallon Skid Sprayer w/205cc B&S Engine, 8-Roller Pump & Deluxe Handgun)

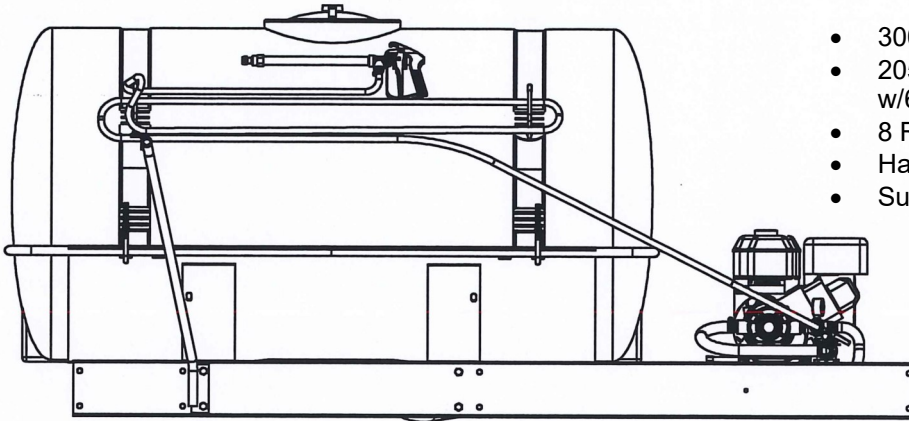

Technical Specifications

- 300 Gallon Polyethylene Tank
- 205cc B&S Engine, 8.0 Gross Torque w/6:1 Gear Reduction
- 8 Roller Pump - 10 GPM @ 250 PSI
- Handgun w/25' of Hose
- Suction Line Filter

Caution: When fully filled with water, this sprayer will weigh approx. 2,760 lbs.. Consult the owner's manual for your vehicle to verify that you are within it's load carrying capacity.

BEFORE RETURNING THIS PRODUCT FOR ANY REASON, PLEASE CALL
1-800-831-0027

IF YOU SHOULD HAVE A QUESTION OR EXPERIENCE A PROBLEM WITH YOUR FIMCO INDUSTRIES PRODUCT:
1-800-831-0027

BEFORE YOU CALL, PLEASE HAVE THE FOLLOWING INFORMATION AVAILABLE: SALES RECEIPT & MODEL NUMBER. IN MOST CASES, A FIMCO INDUSTRIES EMPLOYEE CAN RESOLVE THE PROBLEM OVER THE PHONE.

General Information

Thank you for purchasing this product. The purpose of this manual is to assist you in operating and maintaining your Skid Sprayer.



WARNING: To reduce the risk of injury, the user must read and understand the operator's manual before using this product.



WARNING: Cancer and Reproductive Harm
www.P65Warnings.ca.gov

Retain a copy of your receipt for your unit, as it will be required to validate any warranty service. Products are warranted against manufacturer or workmanship defects for one year from date of purchase for home owner usage and 90 days for commercial usage.

For technical assistance, visit our website @ www.fimcoindustries.com or call: **TOLL FREE @ 1-800-831-0027**

Our Technical Support Representatives will be happy to help you.

To obtain prompt, efficient service, always remember to give the following information...

- Correct Part Description and/or part number
- Model #/Serial # of your sprayer

Part descriptions and numbers can be obtained from the illustrated parts list section(s) of this manual.

Assembly Instructions

1. Do not tighten the nuts and bolts until all parts are in place. Saw horses or some other kind of stand may be used as a work base for easier assembly, but be sure that the footing is secure, so that the unit will not fall from the stand, which could result in damage and/or injury.
2. Read through all of the instructions before starting the assembly. Refer to the exploded view drawings and parts lists to identify the parts used in assembly.
3. Bolt the parts together as shown on the exploded view. Note the position of the holes in the cross members.
4. Mount the saddle together to the cross members using (4) 1/2" x 1-1/4" hex cap screws and (4) 1/2" flange locknuts.
5. The engine and pump have been sub-assembled at the factory. Use (4) 5/16" x1-1/2" bolts to attach the engine to the skid base plate. Secure in place with (4) 5/16" hex flange locknuts.
6. Thread the fittings into the tank bottom ports. Use a good grade of thread sealant or plumber's Teflon tape on ALL fittings to insure no leaks in the plumbing system.
7. Attach the hose clip to the suction hose to the right side of the skid, using (1) 1/4" x 1" flange lockscrew and (1) 1/4" flange locknut (See Detail C).
8. Attach the strainer bracket to the base plate as shown in the exploded view drawing, using (1) 5/16" x 5/8" flange screw and (1) 5/16" flange locknut.
9. Connect the suction line fittings and bypass line fittings (from the tank to the pump fittings) with hoses. Secure the hoses in place with their respective hose clamps. (Refer to the exploded view drawings for correct hose lengths and hose clamp sizes used).
10. Join the handgun hose to the handgun and to the fitting at the pump. Secure with hose clamps.
11. Wrap the handgun hose around the hose holders which are attached to the tank straps.



www.fimcoindustries.com

1000 FIMCO Lane, P.O. Box 1700, North Sioux City, SD 57049
Toll Free Phone: 800-831-0027 : Toll Free Fax: 800-494-0440

[5004381

(12/18)]

IMPORTANT: Remove tank lid and be sure the tank is clean and free of any foreign material. Rinse tank out of any tank residue before filling with water to test.

Information About the Sprayer

Roller pumps are positive displacement pumps, which means that the entire solution being pumped must go somewhere or the pump will break. In this roller pumping system, solution is drawn from the tank and forced to a planned source, such as a handgun. The pressure is controlled by a pressure relief valve, which is a spring-loaded device that controls the amount of fluid bypassed (recirculated) to the tank. The gray adjusting cap is to be tightened to increase pressure and loosened to decrease pressure.

Testing the Sprayer

NOTE:

It is important that you test your sprayer for leakage and proper spray patterns with plain water before chemical application is attempted. This will also give you the opportunity to familiarize yourself with the operation of the sprayer, without the possibility of losing any expensive chemicals.

1. Fill the tank about 1/2 full with plain water.
2. Open the valve in the suction line and allow water to flow to the pump. The valve is located at this point to enable the strainer to be taken apart for cleaning, while solution remains in the tank.

CAUTION: Always be sure that the water (or solution) has reached the roller pump before starting your sprayer. If the pump is allowed to run dry, serious damage to the pump will result. Do not run your sprayer with the boom/handgun line closed AND the bypass line closed. Doing this will damage the pump.

3. It is always best to start the sprayer at little or no pressure. This sprayer is equipped with a spring loaded pressure relief/bypass valve. Turn the valve knob out to decrease pressure and in for increased pressure.

The bypass valve is the "pressure control" for the entire plumbing system. The more the valve is open, the lower your line pressure. Almost fully closed provides maximum pressure to your boom and/or handgun. **NEVER run your system with this valve 100% closed.**

4. You may now start the sprayer engine following the engine manufacturers instructions. Let the sprayer run at low pressure until water has reached the handgun and all air has been purged from the system.

Caution: Care must be taken, being sure the handgun is secured in the operators hand. If this is not done a recoiling action may occur causing damage or personal injury.

5. The pressure should now be increased to 30 - 40 PSI. Operate the sprayer at this increased pressure for 3 to 5 minutes, thoroughly testing the unit before adding chemicals.

When everything tests all right (no leaks and good pressure), add the desired chemicals to the mixture and water combination and start your spraying operation. Adjust the pressure and spray as you did in the testing procedure. The sprayer should now be ready to use.

Conditions of weather and terrain must be considered when setting the sprayer. Do not spray on windy days. Protective clothing must be worn in some cases

Be sure to read the chemical label(s) before application!

Priming the pump

To help prime the pump, keep the inlet or suction line as short as possible with a minimum of bends, elbows and kinks. Make sure all connections are tight and do not leak air. Make sure the line strainer is free of debris. If pump does not self-prime, disconnect suction hose, fill with water and reconnect to liquid source. Often a squirt of oil into the ports of the pump will seal clearances and help priming. Facing the pump, the suction port is on your left.

Maintenance During/After Spraying

Periodically close the suction line valve and check the line strainer and clean the screen. Stop the engine and shut off the valve near the strainer. Remove the bowl and screen portions of the strainer and wash them free from all impurities. You may also drain the tank by uncoupling the suction line near the strainer. Open the valve and pour the contents into another container. Read the chemical label for disposal instructions.

Proper care and maintenance will keep your pump wear at a minimum and will keep it running smoothly and trouble-free for a long time and prolong the life of your sprayer.

After use, fill the sprayer tank part way with water. Start the sprayer and allow the water to pump through the entire plumbing system and nozzles. Drain and then refill half full with plain water, add the recommended amount of good quality tank cleaner such as FIMCO Sprayer Tank Neutralizer and Cleaner. (If no tank cleaner is available, you may substitute dish soap for this step, about 1-2 oz. per gallon). Turn sprayer on and circulate through system for 15 minutes and then spray out through handgun nozzle (and boom nozzles if applicable). Refill tank half way with clean water and repeat. Follow the chemical manufacturer's disposal instructions of all wash or rinsing water.

For the boom (if applicable) remove the tips and screens from the nozzle assemblies. Wash these items out thoroughly. Blow the orifice clean and dry. If the orifice remains clogged, clean it with a fine bristle (NOT WIRE) brush or with a toothpick. Do not damage the orifice. Water rinse and dry the tips before storing.

Flush the pump after each use. One of the common causes of faulty pump performance is "gumming" or corrosion inside the pump. This prevents the rollers from moving freely. Flush the pump with a solution that will neutralize liquid pumped. A rust inhibitor can also be squirted into the ports of the pump. Turn shaft several times to draw protective liquid through pump and coat entire inner surface.

WARNING: Never pump corrosive or abrasive liquids as these will cause rapid wear or deterioration of body, rotor, shaft and seals in the pump. Never run pump dry. Some chemicals will damage the pump valves if allowed to soak untreated for a length of time! ALWAYS flush the pump as instructed after each use. DO NOT allow chemicals to sit in the pump for extended times of idleness. Failure to follow this warning will void the product warranty.

Follow the chemical manufacturer's instructions on disposal of all waste water from the sprayer.

Winter Storage

Prepare the sprayer for end-of-season storage by draining all water out of your sprayer, paying special attention to the pump, handgun and valve(s). These items are especially prone to damage from chemicals and freezing weather.

The sprayer should be winterized before storage by pumping a solution of automotive antifreeze (containing a rust inhibitor) through the entire plumbing system. This antifreeze solution should remain in the plumbing system during the winter months. When spring time comes and you are preparing your sprayer for the spray season, rinse the entire plumbing system out, clearing the lines of the antifreeze solution.

Proper care and maintenance will prolong the life of your sprayer.

It is nearly impossible to drain all of the water from the sprayer and any trapped water can freeze in cold weather and damage parts of the sprayer. Pumping the antifreeze through the system will displace the water and help prevent this damage.

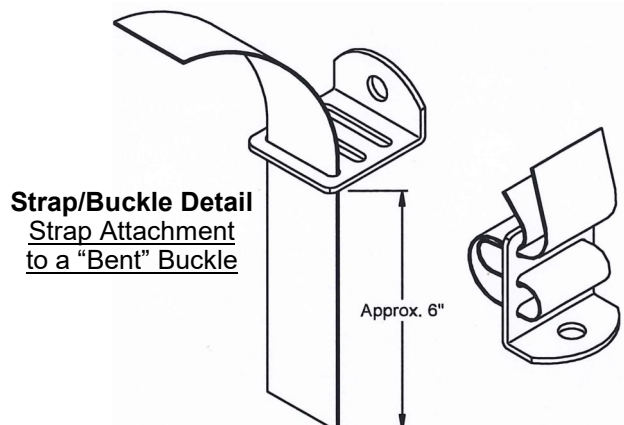

Strap/Buckle Detail
Strap Attachment
to a "Bent" Buckle

The nylon straps are to be inserted in and out of the slots in the buckle, as shown. Be sure the straps are snug before tightening the hook bolts. In most cases, it will be necessary to re-tighten the straps after filling the tank with liquid.

Exploded View/
Parts List:
9-300 (5300656)

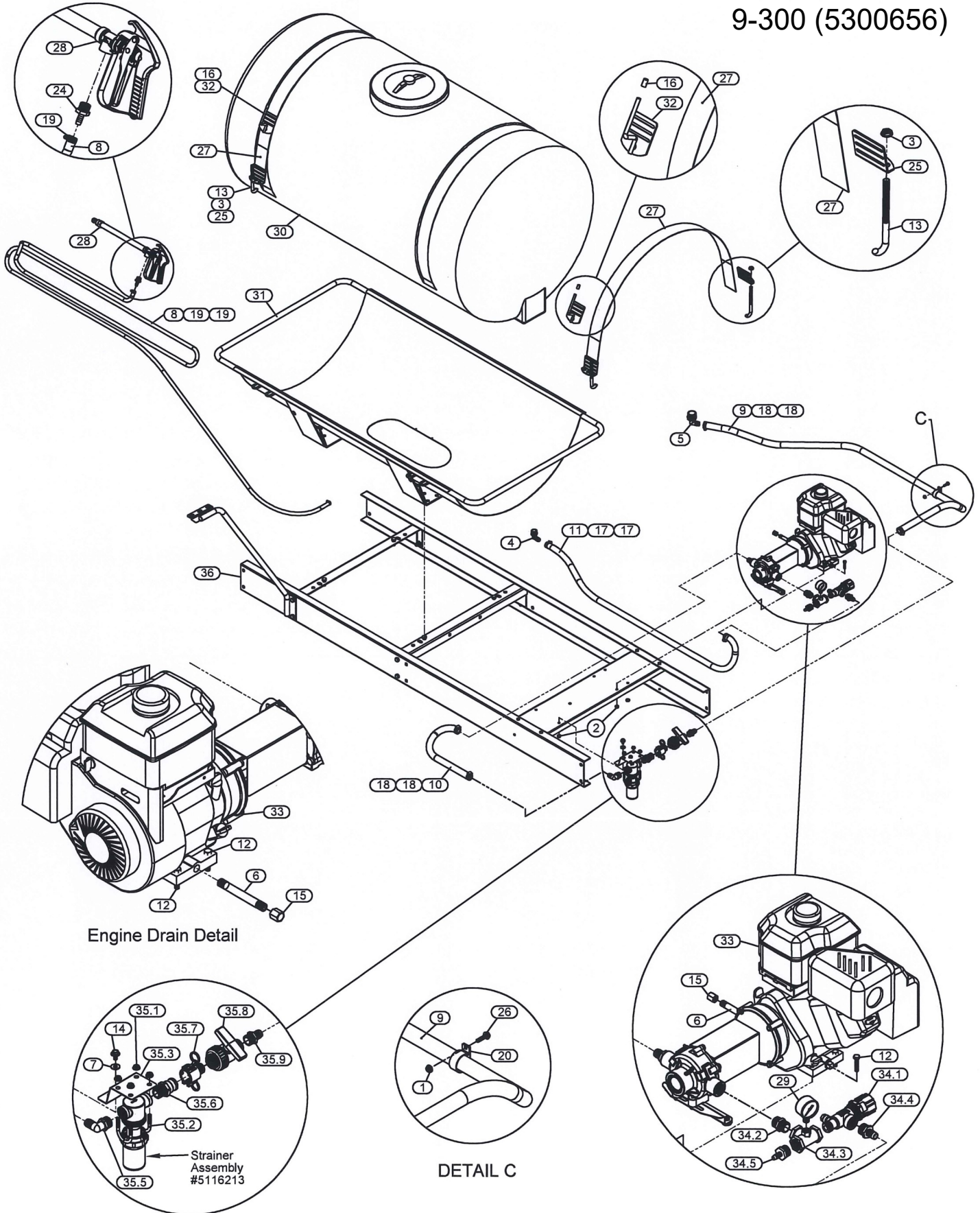

Engine Drain Detail

Strainer Assembly
#5116213

DETAIL C

Exploded View/Parts List: 9-300 (5300656)

Ref. #	Part #	Description	Qty.
1	5006306	1/4"-20nc Hex Flanged Whiz Nut, Grade 5	1
2	5006307	5/16"-18nc Hex Flanged Whiz Nut, Grade 5	5
3	5006337	1/2-13 Hex Whiz (Flange) Locknut	4
4	5010208	Poly Elbow, 3/4" MNPT x 5/8" HB	1
5	5010214	Poly Elbow, 1-1/4" MPT x 3/4" HB	1
6	5011126	1/4" x 4-1/2" Galv. Pipe Nipple	1
7	5016020	Flatwasher, 5/16"	1
8	5020099	Hose, 3/8"-2 Brd. x 25'	1
9	5020104	Hose, 3/4"-2 Brd. X 78"	1
10	5020105	Hose, 3/4"-2 Brd. X 36"	1
11	5020429	Hose, 5/8"-1 Brd. x 64"	1
12	5034638	5/16"-18 x 1-1/2" Fling Hex Bolt	4
13	5034111	1/2" x 6" J-Hook Bolt	4
14	5034634	5/16"-18 x 5/8" Flange Hex Bolt	1
15	5046057	1/4" NPT Galv. Hex Pipe Cap	1
16	5046085	Cap	2
17	5051023	Hose Clamp, 5/8"	2
18	5051024	Hose Clamp, 3/4"	4
19	5051144	Hose Clamp, 3/8"	2
20	5053075	Clip	1
21	5063067	Orifice Disc, D2	1
22	5063069	Orifice Disc, D4	1
23	5063073	Orifice Disc, D8	1
24	5067130	Poly Fitting, 1/2" MNPT x 3/8" HB	1
25	5108112	Tank Strap Buckle, Bent	4
26	5117301	1/4-20 x 1" Hex Flange Screw	1
27	5133274	Tank Strap, 3" x 84"	2
28	5163005	GunJet Spray Gun (AA43H-AL6)	1

Ref. #	Part #	Description	Qty.
29	5167005	Gauge, 0-400 PSI (Dry)	1
30	5169002	300 Gallon Tank (38" x 73" x 62-1/2") (White)	1
30.1	63480	8" Lid w/Blue Snap-In Vent	1
31	5273831	38"-300 Saddle Weldment	1
32	5274364	Hose Hanger Weldment	2
33	5275145	Engine/Pump Sub-Assembly	1
34	5275337	Pressure Relief Valve Assembly	1
34.1	5143199	Pressure Relief Valve (3/4" NPT)	1
34.2	5011140	Poly Close Nipple, 3/4" MNPT	1
34.3	5010257	Poly Gauge Tee, 3/4" FPT	1
34.4	5067126	Poly Fitting, 3/4" MNPT x 5/8" HB	1
34.5	5067124	Poly Fitting, 3/4" MNPT x 3/8" HB	1
35	5275953	Strainer Assembly	1
35.1	5006307	5/16"-18nc Hex Flanged Whiz Nut, Grade 5	4
35.2	5034065	Round U-Bolt, 5/16"-18 x 1-1/2" x 2-3/16"	2
35.3	5038258	Strainer Bracket	1
35.4	5116213	Strainer	1
35.4.1	3351-0039	Strainer Bowl	1
35.4.2	5116131	Strainer Screen (40 Mesh)	1
35.4.3	5072299	Strainer EPDM Gasket	1
35.4.4	3351-0038	Strainer Cap	1
35.5	5010209	Poly Elbow, 3/4" MPT x 3/4" HB	1
35.6	5005158	Banjo Male Adapter, 3/4" MPT	1
35.7	5057109	Banjo Female Coupler, 3/4" MPT	1
35.8	5143206	3/4" Single Union Ball Valve	1
35.9	5067127	Poly Fitting, 3/4" MPT x 3/4" HB	1
36	5300053	SK-3 Skid	1

Setting "A"
Wide Angle Cone Spray

Setting "C"
Straight Stream Spray

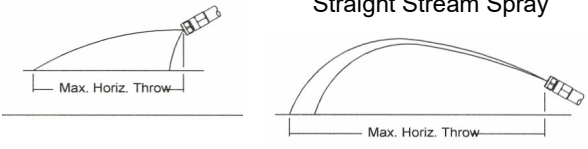

Tip No.	Data	Liquid Pressure in Lbs. per Square Inch							
		40 PSI Setting		100 PSI Setting		200 PSI Setting		300 PSI Setting	
		"A"	"C"	"A"	"C"	"A"	"C"	"A"	"C"
D-2	Capacity GPM	.29	.30	.45	.47	.64	.66	.78	.81
	Spray Angle	20°	--	25°	--	20°	--	19°	--
	Max. Throw - Ft.	10	32	10	33	10	34	10.5	35
	Max. Vert. Throw - Ft.	--	22	--	22	--	23	--	23
D-4	Capacity GPM	.60	.61	.92	.94	1.3	1.3	1.6	1.6
	Spray Angle	22°	--	26°	--	24°	--	20°	--
	Max. Throw - Ft.	10	36	10	36	10.5	37	10.5	38
	Max. Vert. Throw - Ft.	--	26	--	27	--	28	--	29
D-6	Capacity GPM	1.2	1.3	1.9	2.0	2.7	2.9	3.3	3.5
	Spray Angle	38°	--	41°	--	38°	--	35°	--
	Max. Throw - Ft.	10	44	10	45	10.5	46	11	47
	Max. Vert. Throw - Ft.	--	28	--	30	--	32	--	33
D-8	Capacity GPM	2.0	2.2	3.1	3.4	4.4	4.8	5.3	5.9
	Spray Angle	48°	--	50°	--	48°	--	43°	--
	Max. Throw - Ft.	10	45	10	46	10.5	47	11	48
	Max. Vert. Throw - Ft.	--	29	--	32	--	35	--	36

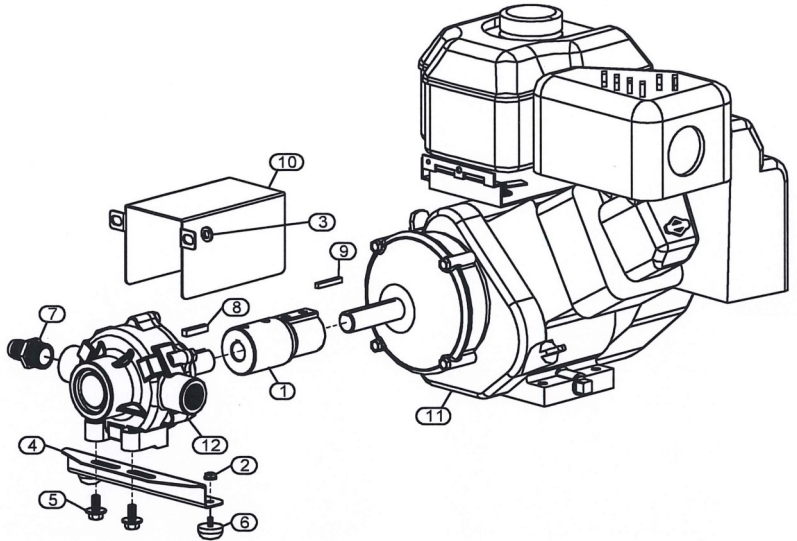

Engine/Pump Sub-Assembly (5275145)

Ref. #	Part #	Description	Qty.
1	505177	Adapter & Kit (Coupler)	1
2	5006186	#10-24 Serrated Flng Hex Nut	2
3	5016026	Lockwasher, 5/16"	2
4	5023052	Torque Bracket	1
5	5034634	5/16"-18 x 5/8" Flange Hex Bolt	2
6	5040004	Rubber-Headed Mach. Screw Bumper (#10-24)	2
7	5067127	Poly Fitting, 3/4" MPT x 3/4" HB	1
8	5089003	1/4" Square Keystock x 1-1/4" Long	1
9	5089033	3/16" Square Keystock x 1-3/8" Long	1
10	5120044	Shield	1
11	5152099	205cc B&S Engine w/Gear Reduction	1
12	5271509	Cast Iron 8-Roller Pump (Reverse Rotation)	1

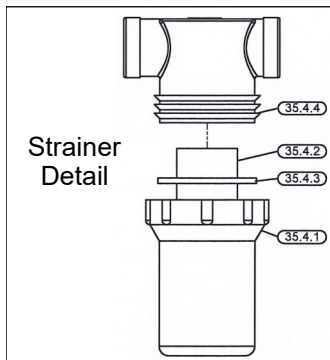

SK-3 Skid Assembly (5275145)

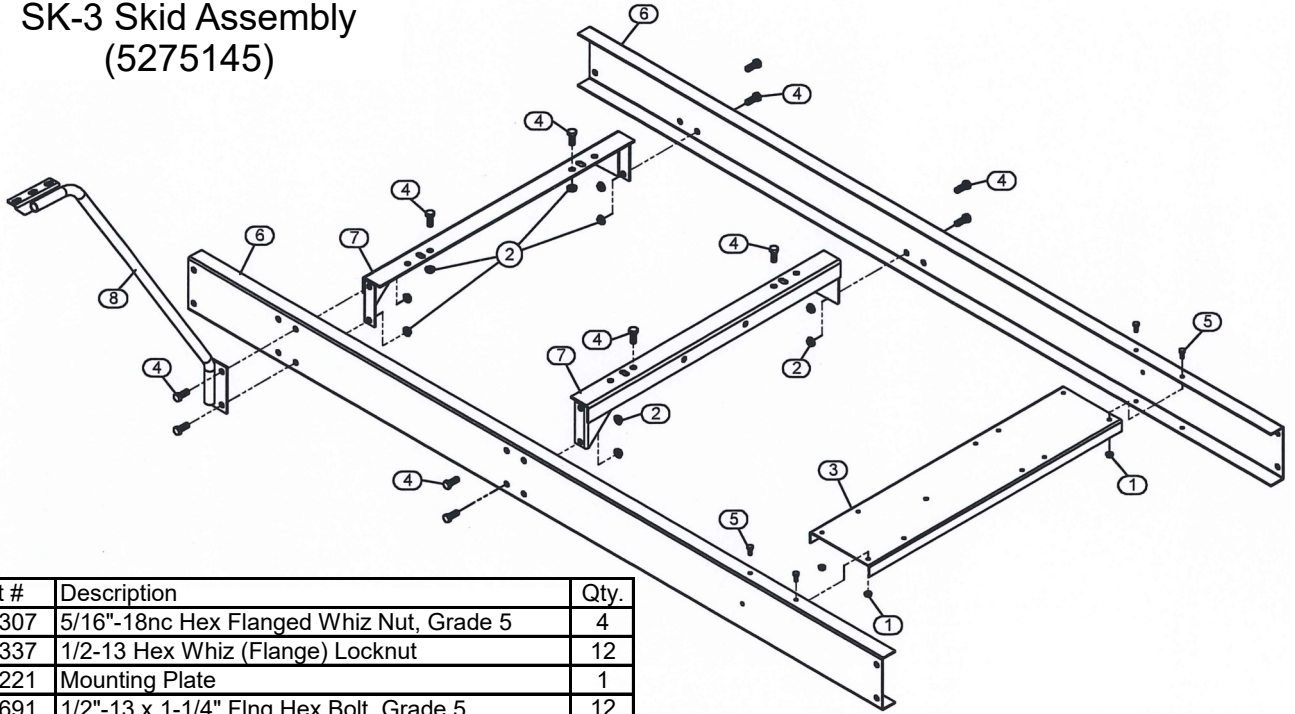

Ref. #	Part #	Description	Qty.
1	5006307	5/16"-18nc Hex Flanged Whiz Nut, Grade 5	4
2	5006337	1/2-13 Hex Whiz (Flange) Locknut	12
3	5017221	Mounting Plate	1
4	5034691	1/2"-13 x 1-1/4" Flng Hex Bolt, Grade 5	12
5	5117323	5/16"-18nc x 3/4" Flng Hex Bolt	4
6	5156005	Skid Slide Frame Member	2
7	5271632	Cross Member Weldment	2
8	5271633	Valve Mount Weldment	1

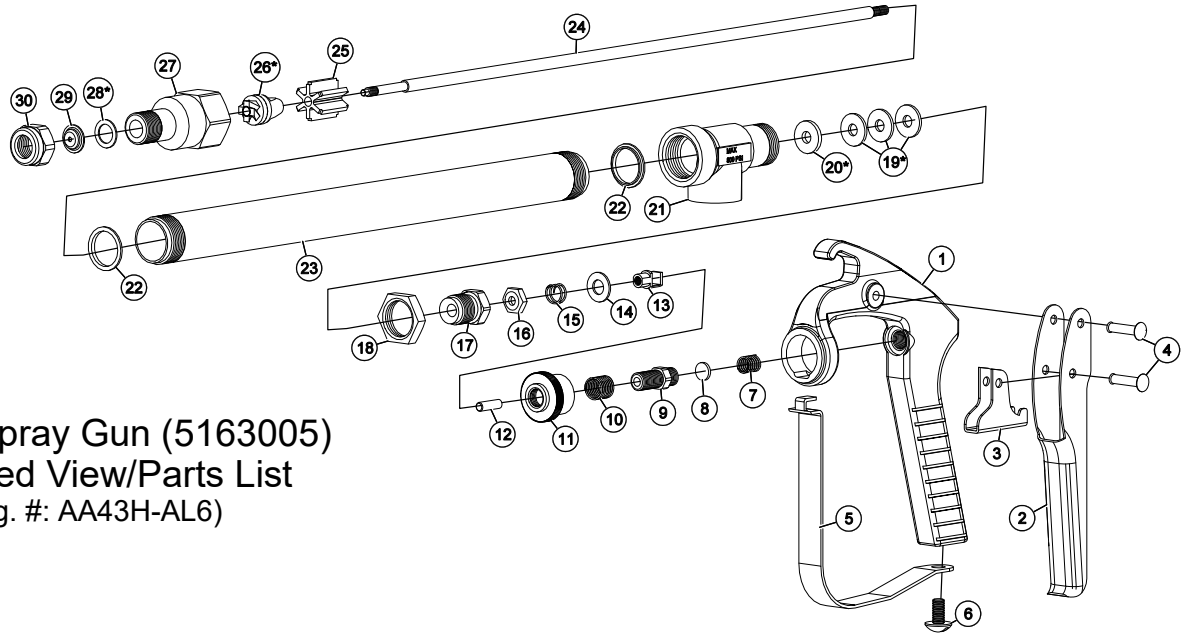

GunJet Spray Gun (5163005) Exploded View/Parts List (Mfg. #: AA43H-AL6)

Ref. #	Part #	Mfg. Part #	Description	Qty
1	5002205	CP14477-1-AL	Handle Body, Aluminum	1
2	5166026	CP6509-INP	Trigger, Steel - Nickel Plated	1
3	◆◆	CP6510-INP	Trigger Stop, Steel - Nickel Plated	1
4	◆◆	CP7623-I-ZP	Rivet, Steel - Zinc Plated	2
5	◆◆	CP13798-INP	Trigger Guard, Steel - Nickel Plated	1
6	◆◆	CP11757-INP	Screw, Stainless Steel	1
7	5019107	CP6593-2-SS	Main Spring, Stainless Steel	1
8	5016071	CP6592-302SS	Spring Guide Washer, Type 302 S.S.	1
9	5117070	CP6588-I-ZP	Spring Screw, Steel - Zinc Plated	1
10	5019069	CP6594-SS	Spring for Stop Adjustment Nut, S.S.	1
11	5006072	CP6589-I-ZP	Stop Adjustment Nut, Steel - Zinc Plated	1
12	5134010	CP6591-SS	Spring Stud, Stainless Steel	1
13	5166017	CP6597-INP	Trigger Guide, Steel - Nickel Plated	1
14	5016061	CP7991-I-ZP	Washer	1
15	5019083	CP6595-SS	Trigger Stop Spring, Stainless Steel	1
16	5006244	CP9641-INP	Stem Nut, Steel - Nickel Plated	1

Ref. #	Part #	Mfg. Part #	Description	Qty
17	5117165	CP19237-AL	Packing Screw, Aluminum	1
18	◆◆	CP6599-NP	Locknut, Steel - Plated	1
19*	5097021	CP6602-LEA	Packing, Leather	3
20*	5016063	CP6601-302SS	Packing Washer, Type 302 Stainless Steel	1
21	5002203	CP6492-AL	Inlet Body, Aluminum	1
22	CP45196-NYB	CP45196-NYB	Gasket, Nylon	2
23	5009080	CP6604-AL	Tubing, Aluminum	1
24	5132039	CP19238-416SS	Stem, Type 416 Stainless Steel	1
25	◆◆	CP10571-AL	Guide Vane	1
26*	10565-1-NY-AL	10565-1-NY-AL	Seat Plug, Plate, Washer, & Core Sub-Assy.	1
27	5084016	CP10566-AL	Nozzle Housing, Aluminum	1
28*	5072105	CP4743-NY	Gasket, Nylon	1
29	5063071	D6	Orifice Disc, Stainless Steel (D6)	1
30	5046033	CP1325-AL	Cap, Aluminum	1

*: Available in Spare Parts Kit ONLY #5168190 (Mfg. #: PK-AB43-AL-KIT)

◆◆: Only Available in Complete Handgun Assembly

Piston Type Pressure Relief/Regulating Valves

Bypasses excess fluid. Adjustable to maintain control of line pressure at any pressure within the valve operating range. Selected pressure setting firmly held in place by locknut. Extra large passages to handle large flows.

- Polypropylene with stainless steel spring
- Excellent chemical resistance
- EPDM O-Rings
- Fore pressure to 150 p.s.i.
- 1/4" port for pressure gauge
- Choice of 1/2" or 3/4" NPT (M) inlet & (F) outlet connections

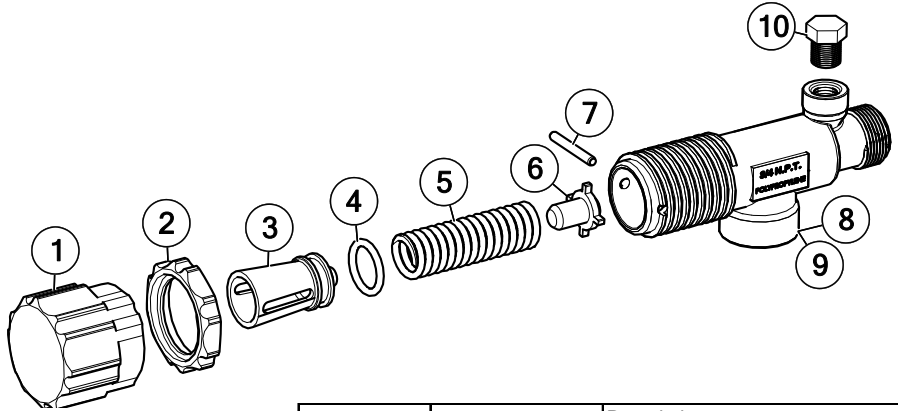

Ref. #	Part #	Mfg. Part #	Description	Qty
1	5046270	CP23122-NY	Adjusting Cap, Nylon (Gray)	1
2	5110266	CP23123-PP	Lock Ring	1
3	◆◆	CP23124-PP	Spring Retainer	1
4	**	CP7717-15-EPR	O-Ring, EPDM Rubber	1
5	**	CP23127-302SS	Spring	1
6	◆◆	CP23125-PP	Guide Seat	1
7	**	CP23126-302SS	Retaining Pin	1
8	CP23121-PP	CP23121-PP	Poly Body (3/4" NPT)	1
9	CP23128-PP	CP23128-PP	Poly Body (1/2" NPT)	1
10	5102022	F14	Pipe Plug, 1/4" MNPT	1

Fimco #	Mfg. Part #	Description
5143199	23120-3/4-PP	Pressure Relief Valve (3/4" NPT)
5143200	23120-1/2-PP	Pressure Relief Valve (1/2" NPT)
5168717	PK-AB23120-KIT	Repair Kit, Items Marked **

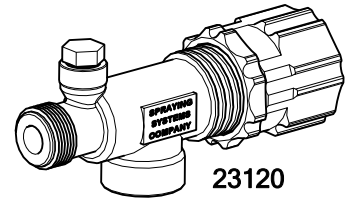

** Available only in Repair Kit #5168717 (PK-AB23120-KIT)
◆◆ Only Available in Complete Assembly

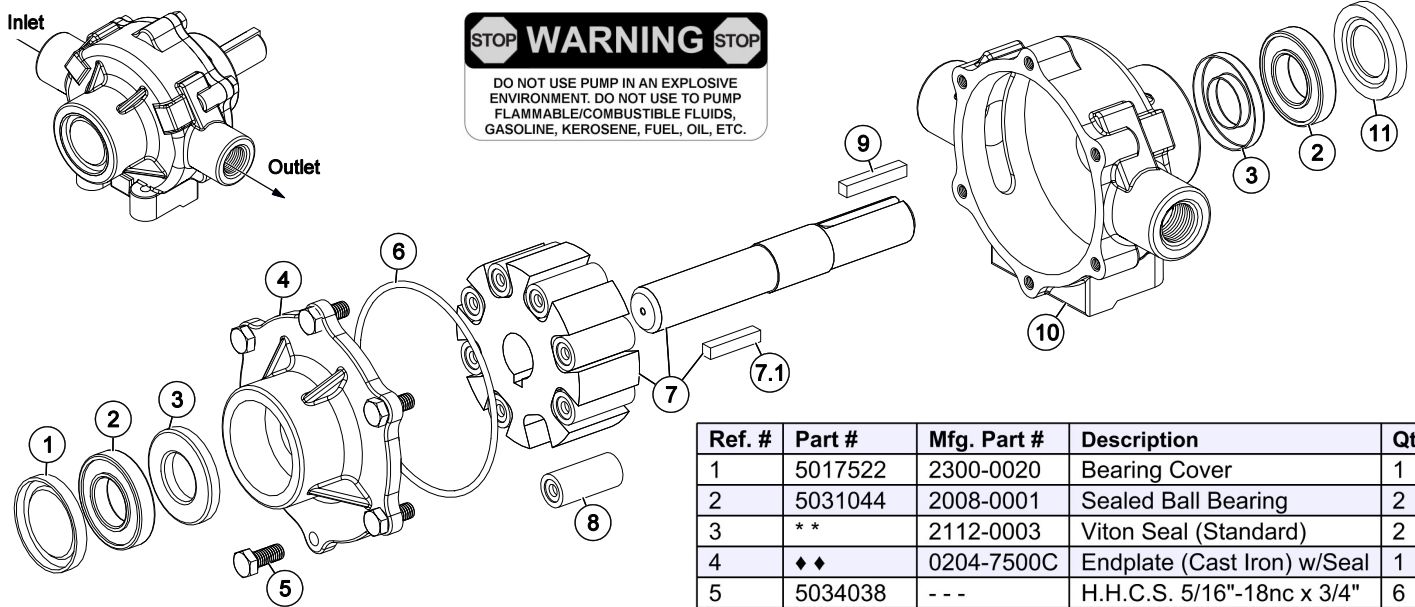

STOP WARNING STOP
DO NOT USE PUMP IN AN EXPLOSIVE ENVIRONMENT. DO NOT USE TO PUMP FLAMMABLE/COMBUSTIBLE FLUIDS, GASOLINE, KEROSENE, FUEL, OIL, ETC.

**Cast Iron
8-Roller Pump Assembly**
#5271509 (Hypro Mfg. Part #: 7560C-R-01)

** Available only in Repair Kit #7771794 (3430-0381)
◆◆ Only Available in Complete Assembly

Ref. #	Part #	Mfg. Part #	Description	Qty
1	5017522	2300-0020	Bearing Cover	1
2	5031044	2008-0001	Sealed Ball Bearing	2
3	**	2112-0003	Viton Seal (Standard)	2
4	◆◆	0204-7500C	Endplate (Cast Iron) w/Seal	1
5	5034038	- - -	H.H.C.S. 5/16"-18nc x 3/4"	6
6	**	1720-0014	O-Ring Gasket for Endplate	1
7	5172113	0308-7560C	Rotor w/Shaft Assembly	1
7.1	1610-0059	1610-0059	Key (Stainless Steel)	1
8	5112030	1005-0004	Super Roller (Standard)	8
9	5089012	1610-0005	Key	1
10	◆◆	0104-7500C	Body (Cast Iron) w/Seal	1
11	5017523	2300-0022	Shaft Bearing Cover	1

Pump Speed (RPM)	0 PSI		50 PSI		100 PSI		150 PSI		200 PSI		250 PSI		300 PSI	
	GPM	HP	GPM	HP	GPM	HP	GPM	HP	GPM	HP	GPM	HP	GPM	HP
600	14.0	0.45	13.1	0.87	12.1	1.41	11.2	1.98	10.6	2.5	10.0	3.1	9.1	3.7

Roller Pump General Safety Information

1. Use a pressure relief device on the discharge side of the pump to prevent damage from pressure buildup when the pump discharge is blocked or otherwise closed and the power source is still running.
2. **WARNING:** Never pump flammable or explosive fluids such as gasoline, fuel oil, kerosene, etc. Never use in explosive atmospheres. The pump should be used only with liquids compatible with the pump component materials. Failure to follow this warning can result in personal injury and/or property damage and will void the product warranty.
3. Never pump acids (i.e. acid fertilizer) with Super Rollers!
4. Never run the pump faster than maximum recommended speed.
5. Never pump at pressures higher than the maximum recommended pressure.
6. Never pump liquids at temperatures higher than the recommended maximum temperatures (140°F/60°C).
7. Make certain that the power source conforms to the requirements of your equipment.
8. Provide adequate protection in guarding around the moving parts such as the shaft and pulleys.
9. Disconnect power before servicing.
10. Release all pressure within the system before servicing any component.
11. Drain all liquids from the system before servicing any component.
12. Check all hoses for weak or worn condition before each use. Make certain that all connections are tight and secure.
13. Periodically inspect the pump and the system components. Perform routine maintenance as required.
14. Never operate a gasoline engine in an enclosed area. Be sure the area is well ventilated.
15. Use only pipe, hose and fittings rated for the maximum psi rating of the pump.
16. Never use pump for pumping water or other liquids for human or animal consumption.

Roller Pump Operation & Maintenance

WARNING: Never pump corrosive or abrasive liquids as these will cause rapid wear or deterioration of the body, rotor, shaft and seals in the pump. The pump should be used on with liquids compatible with pump component materials. Never exceed maximum specified rpm and pressure. Never run pump dry. Failure to follow this warning will void the product warranty.

Priming the Pump:

To help prime the pump, keep the inlet or suction line as short as possible with a minimum of bends, elbows and kinks. Make sure all connections are tight and do not leak air. Make sure line strainer is free of debris. If pump does not self-prime, disconnect suction hose, fill with water and reconnect to liquid source. Often a squirt of oil into the ports of the pump will seal clearance and help priming.

Care of the Pump:

Proper care and maintenance will keep your pump wear at a minimum and will keep it running smoothly and trouble-free for a long time.

Flush the Pump After Each Use

One of the common causes of faulty pump performance is “gumming” or corrosion inside the pump. This prevents rollers from moving freely in their rotor slots. Flush the pump with a solution that will neutralize liquid pumped, mixed according to manufacturer’s directions.

To Prevent Corrosion:

After cleaning pump as above, flush it with a 50-50 solution of permanent-type automotive antifreeze (containing a rust inhibitor) and water. A rust inhibitor can also be squirted into the ports of the pump. Turn shaft several times to draw protective liquid through pump and coat entire inner surface. Drain pump and plug ports to keep out air during storage. For short periods of idleness, noncorrosive liquids may be left in the pump, but air must be kept out. Plug ports or seal port connections.

Troubleshooting		
Symptom	Probable Cause(s)	Corrective Action
Pump Does Not Prime	Leak in suction line	Check hose and fittings for leaks and correct
	Obstruction in suction line	Inspect hose for debris or loose inner liner in hose
	Suction hose sucked to bottom or side of tank	Cut a notch or "V" in end of suction hose
	Rollers stuck in pump	Disassemble pump and inspect rollers
	Pump seals leaking air	Replace seals
Loss of Pressure	Clogged suction strainer	Check strainer and clean it regularly
	Kinked or blocked suction hose	Inspect suction hose and repair as necessary
	Air leak in inlet side plumbing	Check hose and connections for leaks Use pipe joint sealant and retighten connections
	Relief valve setting too low or weakened spring	Check relief valve and correct setting
	Faulty Gauge	Replace gauge
	Pump seals leak air	Replace seals
	Nozzle orifices worn	Replace nozzles
Pump worn	Repair pump	
Pump will not turn	Corrosion (rust), scale or residue	Loosen endplate bolts. Squirt oil into ports to help free rotor. Retighten bolts.
	Solid object lodged in pump.	Disassemble pump and remove objects

Warranty Info

LIMITED WARRANTY FOR NEW FIMCO, INC.

WHO MAY USE THIS LIMITED WARRANTY. This limited warranty (the "Limited Warranty") is provided by Fimco, Inc. to the original purchaser ("you") of the Equipment (as defined below) from Fimco, Inc. or one of Fimco, Inc.'s authorized dealers. This Limited Warranty does not apply to any subsequent owner or other transferee of the Equipment. THIS LIMITED WARRANTY GIVES YOU SPECIFIC LEGAL RIGHTS, AND YOU MAY ALSO HAVE OTHER RIGHTS WHICH VARY FROM STATE TO STATE.

WHAT THIS LIMITED WARRANTY COVERS AND FOR HOW LONG. Fimco, Inc. warrants that any registered new Equipment will be free from defects in material and workmanship for a period of **one (1) year** (homeowner), **90 days** (commercial user), after delivery of the Equipment to you (the "Warranty Period"). The Warranty Period is not extended if Fimco, Inc. repairs or replaces the Equipment.

WHAT IS NOT COVERED BY THIS LIMITED WARRANTY. This Limited Warranty does not apply to: (1) used Equipment; (2) any Equipment that has been altered, changed, repaired or treated since its delivery to you, other than by Fimco, Inc. or its authorized dealers; (3) damage or depreciation due to normal wear and tear; (4) defects or damage due to failure to follow Fimco, Inc.'s operator's manual, specifications or other written instructions, or improper storage, operation, maintenance, application or installation of parts; (5) defects or damage due to misuse, accident or neglect, "acts of God" or other events beyond Fimco, Inc.'s reasonable control; (6) accessories, attachments, tools or parts that were not manufactured by Fimco, Inc., whether or not sold or operated with the Equipment; or (7) rubber parts, such as tires, hoses and grommets.

HOW TO OBTAIN WARRANTY SERVICE. To obtain warranty service under this Limited Warranty, you must (1) provide written notice to Fimco, Inc. of the defect during the Warranty Period and within **thirty (30) days** after the defect becomes apparent or the repair becomes necessary, at the following address: Fimco, Inc., 1000 Fimco Lane, North Sioux City, SD 57049; and (2) make the Equipment available to Fimco, Inc. or an authorized dealer within a reasonable period of time. For more information about this Limited Warranty, please call: **800-831-0027**

WHAT REMEDIES ARE AVAILABLE UNDER THIS LIMITED WARRANTY. If the conditions set forth above are fulfilled and the Equipment or any part thereof is found to be defective, Fimco, Inc. shall, at its own cost, and at its option, either repair or replace the defective Equipment or part. Fimco, Inc. will pay for shipping and handling fees to return the repaired or replacement Equipment or part to you.

LIMITATION OF IMPLIED WARRANTIES AND OTHER REMEDIES. THE REMEDIES DESCRIBED ABOVE ARE YOUR SOLE AND EXCLUSIVE REMEDIES, AND FIMCO, INC.'S SOLE LIABILITY, FOR ANY BREACH OF THIS LIMITED WARRANTY. TO THE EXTENT APPLICABLE, ANY IMPLIED WARRANTIES, INCLUDING, WITHOUT LIMITATION, THE IMPLIED WARRANTIES OF MERCHANTABILITY AND FITNESS FOR A PARTICULAR PURPOSE, SHALL BE LIMITED IN DURATION TO THE WARRANTY PERIOD, AND THE REMEDIES AVAILABLE FOR BREACH THEREOF SHALL BE LIMITED TO THE REMEDIES AVAILABLE UNDER THIS EXPRESS LIMITED WARRANTY. SOME STATES DO NOT ALLOW LIMITATIONS ON HOW LONG AN IMPLIED WARRANTY LASTS, SO THE ABOVE LIMITATION MAY NOT APPLY TO YOU. IN NO EVENT SHALL FIMCO, INC.'S LIABILITY UNDER THIS LIMITED WARRANTY EXCEED THE ACTUAL AMOUNT PAID BY YOU FOR THE DEFECTIVE EQUIPMENT, NOR SHALL FIMCO, INC. BE LIABLE, UNDER ANY CIRCUMSTANCES, FOR ANY CONSEQUENTIAL, INCIDENTAL, SPECIAL OR PUNITIVE DAMAGES OR LOSSES, WHETHER DIRECT OR INDIRECT. SOME STATES DO NOT ALLOW THE EXCLUSION OR LIMITATION OF INCIDENTAL OR CONSEQUENTIAL DAMAGES, SO THE ABOVE LIMITATION OR EXCLUSION MAY NOT APPLY TO YOU.