

OWNER'S MANUAL

Model: ATVBK-200-QR (5302339)

(2-Nozzle Boom Assembly w/Connecting Fittings)

(Tank NOT Included
with Boom Kit)

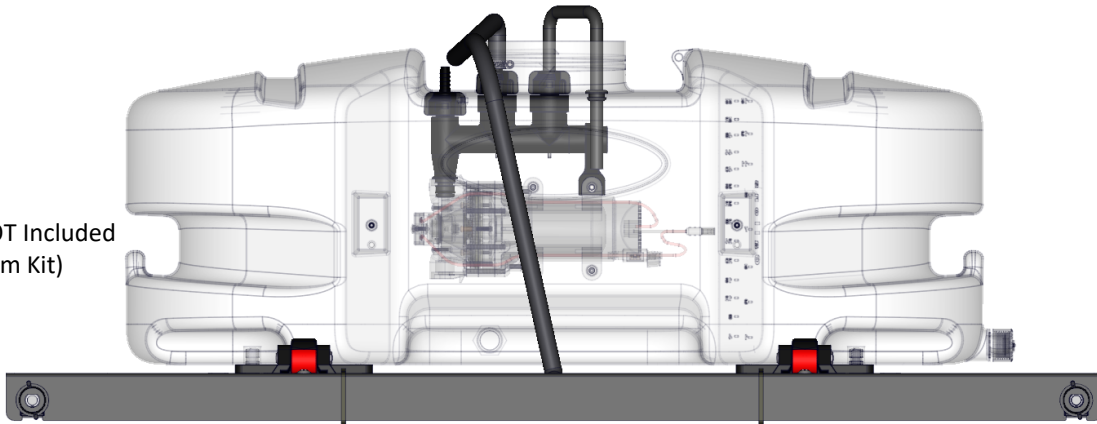

General Information

Thank you for purchasing this product. The purpose of this manual is to assist you in operating and maintaining your Boom Kit.

**BEFORE RETURNING THIS PRODUCT
FOR ANY REASON, PLEASE CALL**

1-800-831-0027

MONDAY-FRIDAY, 8:00 AM TO 5:00 PM CST

If you should have a question or experience a problem with your Fimco Industries Product: Visit our website @ www.fimcoindustries.com or call the Toll free number above. Our technical support representatives will be happy to help you.

In most cases a customer service rep. can resolve the problem over the phone.

To obtain prompt, efficient service, always remember to give the following information....

- Correct Part Description and/or part number
- Model number and Serial Number

Part descriptions and numbers can be obtained from the illustrated parts list section(s) of this manual.

Retain a copy of your receipt for your unit, as it will be required to validate any warranty service.

Warranted against manufacturer or workmanship defects from date of purchase with copy of receipt:

Homeowner Usage: One Year.

Commercial Usage: 90 Days.



WARNING: To reduce the risk of injury, the user must read and understand the operator's manual before using this product.



WARNING: Cancer and Reproductive Harm.
www.P65Warnings.ca.gov



www.fimcoindustries.com

1000 FIMCO Lane, P.O. Box 1700, North Sioux City, SD 57049
Toll Free Phone: 800-831-0027 : Toll Free Fax: 800-494-0440

[5008420

(11/22)]

Contents

Technical Specs.....	2	Calibration.....	6
Boom Kit Contents.....	3	Maintenance, Storing and Winter Storage.....	7
Boom Kit Assembly Instructions.....	4	Boom Kit Exploded View/Parts List.....	8
Plumbing Configurations.....	5	Boom Exploded View/Parts List.....	9
Operation.....	5 - 6	Warranty.....	10

Model: ATVBK-200-QR (5302339) (2-Nozzle Boom Assembly w/Connecting Fittings)

Technical Specifications

- 2-Nozzle Boom Assembly (80" Spray Coverage)
- Corrosion-Resistant Nylon Nozzles
- Nozzle design incorporates a pre-orifice to produce larger droplets for less drift
- Large round orifice reduces clogging
- Excellent distribution for uniform coverage along the boom
- Check Valve Strainers, 50 Mesh, 5 PSI

This boom weighs approx. 10 Lbs.

**Always check the vehicle load rating before using a boom with sprayer, ensuring total weight is acceptable.
Do not exceed the recommended rating.**

~::~~::~~IMPORTANT~::~~

Remove tank lid and be sure the tank is clean and free of any foreign material. Rinse tank out of any tank residue before filling with water to test.

~::~~::~~IMPORTANT~::~~

It is VERY important to test the sprayer, after connecting a boom, with plain water before actual spraying is attempted. This will enable you to familiarize yourself with the sprayer and check for leaks without the possibility of losing any expensive chemicals.

~::~~::~~WARNING~::~~



Read and Understand the Owner's Manual before using this boom. Test and use in accordance to instructions.

Read and Follow chemical label instructions and wear protective gear when filling, using, cleaning and servicing the boom.

Exercise Caution in vehicle handling when towing/hauling a filled sprayer to avoid loss of control or overturning.

Keep Sprayer and Spray materials away from other people, children and pets.

Do Not Turn on Power to the sprayer, until ready to spray in order to avoid unintentional spray release.

Do Not Use on steep slopes. A full sprayer could cause loss of control or overturn sprayer and vehicle.

Always operate up and down a slope, never across the face of a slope.

Keep all movement on slopes slow and gradual. Do not make sudden changes in speed, directions or turning. Do not start or stop suddenly when going uphill or downhill.

Stop on level ground, set the parking brake and shut off engine before leaving the operator's position for any reason.

Keep all parts in good condition and properly installed. Fix damaged or worn parts immediately.

Caution should be taken when towing and/or using any sprayer. The sprayer combined with the weight distribution, turning radius and speed of vehicle can result in damage to vehicle, sprayer and/or boom or severe injury or death, if not used properly.

Improper use or handling of chemicals could result in serious injury or illness, or could cause damage to the environment.

Boom Kit Contents:

2-Nozzle Boom QJ (#5278237)

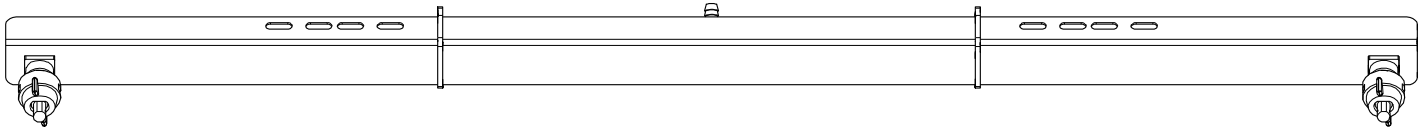

Contents of Parts Bag #5278223

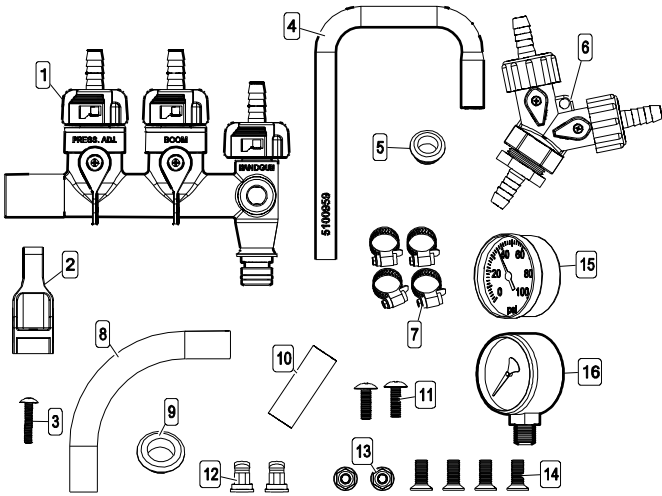

Ref. #	Part #	Description	Qty
1	5281538	Quick Connect Manifold Assembly	1
1.1.1	5072514	O-Ring - Pump Port Connection	1
1.2	5143430	Flat Washer - Hose Barb Seal	3
1.3	5143431	QC Manifold - 3/8 Hose Straight Barb	3
1.4	5143429	Quick Connect Quarter Turn Cap	3
2	5143422	Quick Connect Manifold - Support Bracket	1
3	5117168	#10-24 x 1.00 Phillips Truss Head Mach Screw	1
4	5100959	Formed Bypass Tube	1
5	5075018	Grommet, 1/2 I.D.	1
6	5278323	Y-Valve Assembly	1
7	5051144	Hose Clamp, 3/8	4
8	5020532	Hose, 3/8-1 Brd. x 7 1/4	1
9	5075022	Grommet, 5/8 I.D.	1
10	5020343	Hose, 3/8-1 Brd. x 2	1
11	5117287	1/4-20 x 3/4 Phillips Truss Head Mach Screw	2
12	5018272	Turbo FloodJet Tip (TF-VP2)	2
13	5006306	1/4-20nc Hex Flanged Whiz Nut	2
14	5034149	5/16-18nc x 3/4 Flat Head Screw w/Locking Patch	4
15	5167097	2 Inch Dry 100# Back Mount Gauge	1
16	5167007	Pressure Gauge, 0-100 PSI	1

Contents of Bracket Kit #5278140

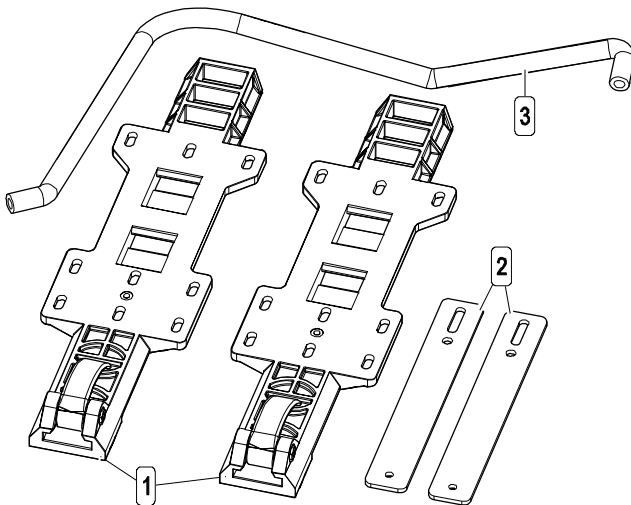

Ref. #	Part #	Description	Qty
1	5278222	Quick Release Bracket Assembly	2
1.1	5078223	Cam Handle Assembly	1
2	5038874-BLK	Boom Mount Bracket-Fixed Height	2
3	5020538	Hose, 3/8-1 Brd. x 43	1

Manifold Detail

See Page 8
for Parts List

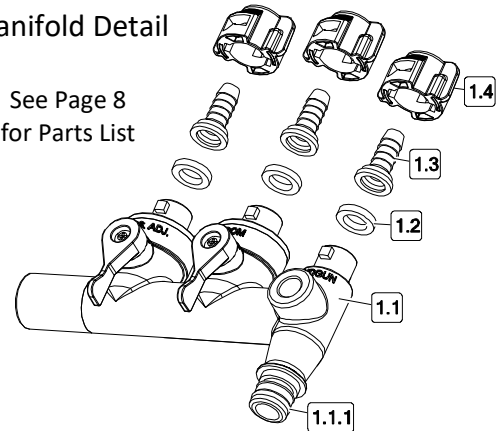

Owner's
Manual



Assembly Procedure

- Make sure the contents of the sprayer's carton match the items shown on page 3 of the manual.
- Follow the steps on pages 4 & 5 to properly assemble the sprayer.

(**) Cam Handle on bracket should be facing towards the 'back' side of the tank.

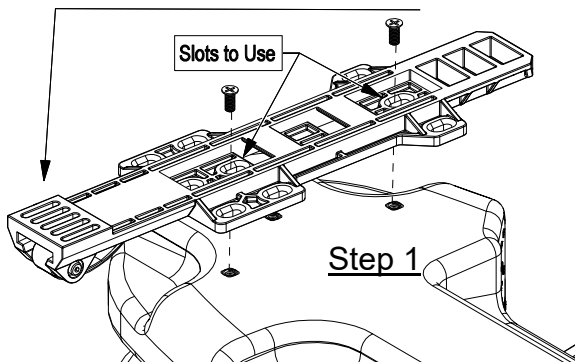

STEP 1:

Normally, the sprayer will be mounted on an ATV with the pump assembly at the operator's back and the spray wand will be at the rear of the unit. Right Hand (RH) and Left Hand (LH) sides of the sprayer are determined as if you are standing behind the sprayer, looking at it (facing forward)

Start the assembly procedure by turning the tank upside down on a stable, flat surface.

A phillips head screwdriver is required for this step.

(**) Mount tank brackets to the underside of the tank as shown in Step 1. Use (4) flat head screws to secure it to the tank. The tank will rest on the surface of the brackets. Make sure the brackets are parallel with each other before tightening down the bolts. Do not over-tighten.

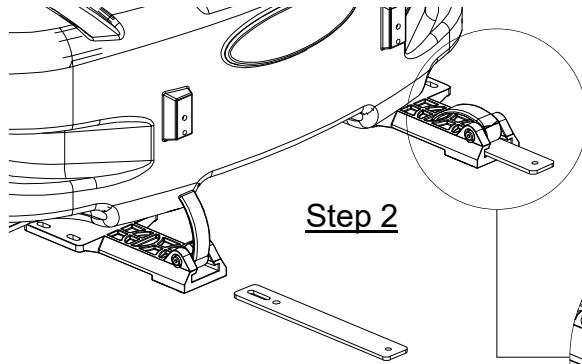

STEP 2:

After your tank brackets are securely attached, turn the tank assembly over and position it so that the cam handles which extend beyond the back of the tank are facing you and just hanging over the edge of the table or flat surface you are assembling this on.

Secure the boom mounting brackets to the tank mounting brackets with Cam handles as shown in Detail A. You can position them as needed within the slot on the bracket. Just be sure that the surfaces of both brackets are even with each other.

You are now ready to mount this unit to an ATV, using ratchet straps (NOT INCLUDED)

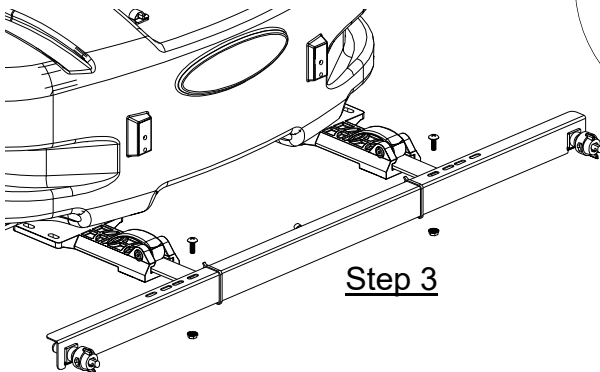

STEP 3:

After your boom mounting brackets are secured in place and the unit secured on your ATV, attach the 2-nozzle boom in place with (2) screws and whiz nuts.

A 1/2" socket or wrench and Phillips Head Screwdriver are required for this step.

Manifold Connection

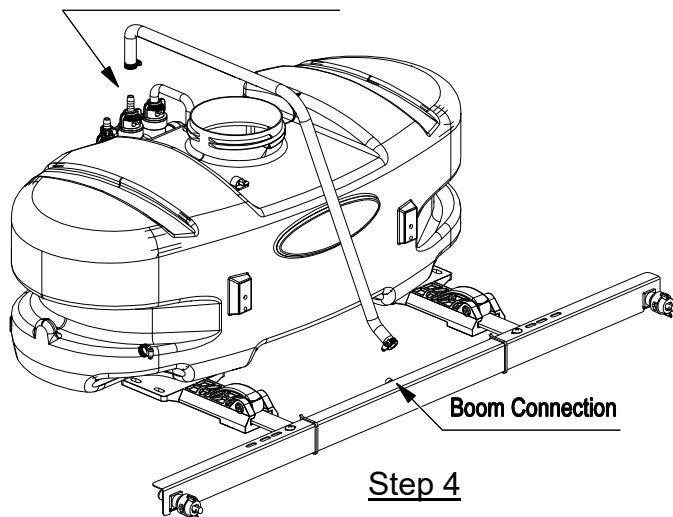

STEP 4:

After your nozzle harness is attached to the boom, locate the 43" hose and the (2) hose clamps from the parts bag.

Place the hose clamps over each end of the hose loosely. Slip the ends of the hose over the hose barb on both the manifold and the poly tee fitting on the nozzle harness. Use a twisting motion, if necessary, to get the hose fully onto each barb. Bring the hose clamps to the connection point and tighten securely.

NOTE:

Make sure this boom feeder hose does not end up on the 'outside' of your spray wand hose, otherwise unwrapping the spray wand hose from around the tank may be difficult.

Plumbing Configurations

See Page 8 for the Parts List and Part Numbers

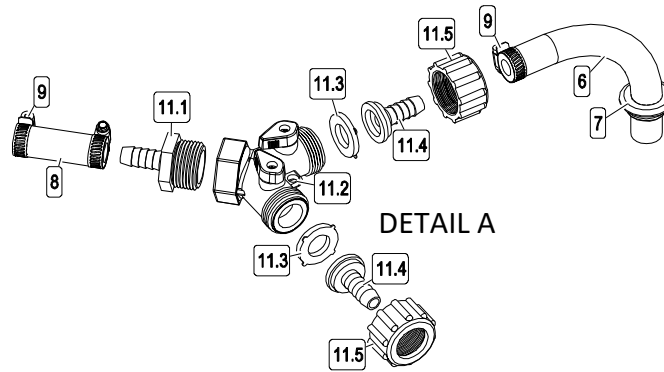

DETAIL A

An additional set of plumbing fittings may be included with your boom kit. These may or may not be used.

DETAIL A: shows the configuration that will be used to attach to your sprayer when hooking up to a 1.2 GPM pump or a top mounted pump.

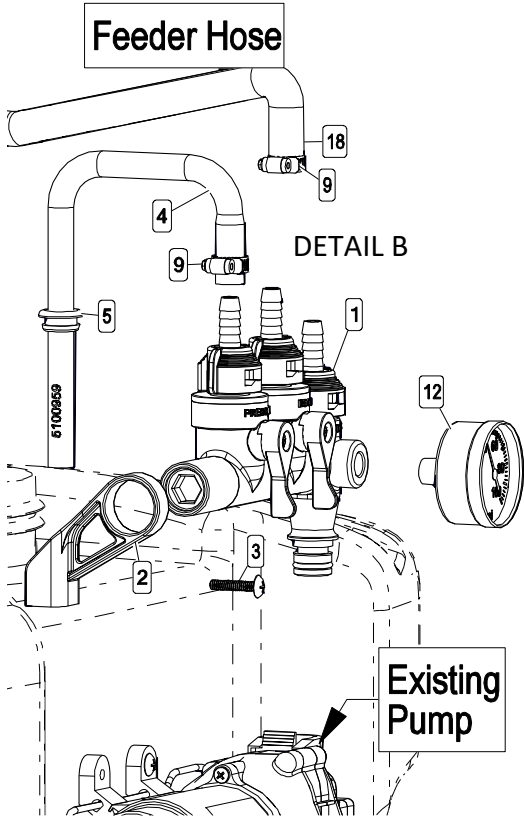

DETAIL B

DETAIL B: shows the configuration that will be used to attach to your sprayer when hooking up to a side mounted pump (2.4 or 4.5).

With either configuration, a hole may need to be drilled through the top of the tank for the bypass return hose. After connecting the needed parts together, depending on which configuration is needed, locate the place on your tank for the hole, so that the hose can be inserted without causing kinks.

Hole Size:

Item 5: 1/2" I.D. Grommet (5075018): a 13/16" hole will need to be drilled.

Item 7: 5/8" I.D. Grommet (5075022): a 7/8" hole will need to be drilled.

Make sure all hose clamps are tight before testing or spraying for the first time.

After completion, sprayer will be ready to TEST w/plain water before actual use.

Testing the Sprayer

NOTE:

It is **VERY** important to test the sprayer, after connecting a boom, with plain water before actual spraying is attempted. This will enable you to familiarize yourself with the sprayer and check for leaks without the possibility of losing any expensive chemicals.

Fill the tank about 1/2 full with plain water and drive to the starting place for spraying.

When you are ready to spray, turn the boom valve to the "on" position (Detail A). This will start solution spraying from the tips of the boom. The pressure will decrease slightly when the boom is spraying.

Adjust the pressure by turning the "ON/OFF" valve lever on the Press. Adj. (bypass) valve (Detail B). Make sure your pattern is sufficient. You may down-pressure the system by 'bypassing' solution back into the tank. This is achieved by opening the Press. Adj. (bypass) valve. Regulating pressure is done in this manner.

Read the operating instructions and initially begin spraying by closing the 'Pressure Adjust' valve and opening the boom line valve (Detail A). This will enable the air in the line to be eliminated (purged) through all the tips, while building pressure. When everything tests all right (no leaks and good pressure), add the desired chemicals to the mixture and water combination and start your spraying operation. Adjust the pressure and spray as you did in the testing procedure.

Conditions of weather and terrain must be considered when setting the sprayer. Do not spray on windy days. Protective clothing must be worn in some cases.

Be sure to read the chemical label(s) before application!

Manifold Valves CLOSED

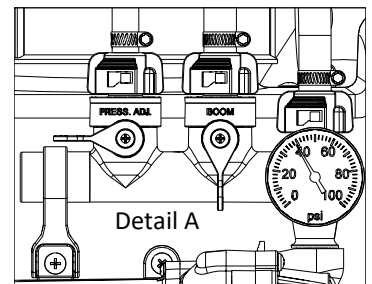
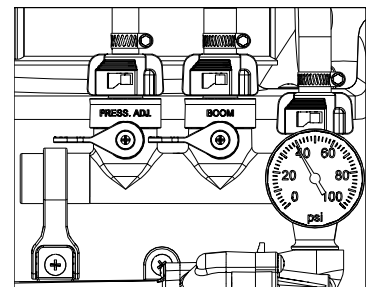

Detail A

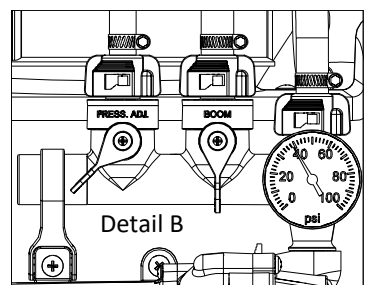

Detail B

Operation

Fill the tank part way with water and then add the desired amount of chemical to be sprayed. Finish filling tank to proper level.

Only fill the tank with what you're going to spray in a day, never leave chemicals sit in tank.

When spraying with either the boom or the handgun, pressure may be reduced by slowly opening the Press. Adj. (bypass) valve until desired pressure is achieved. Opening the valve decreases pressure, closing the valve increases pressure. When spraying with the boom, the proper method to set the pressure is to open the boom valve completely and if a lower pressure is desired, then slowly open the bypass valve until that pressure is obtained.

For the safest and most efficient chemical application, you will need to calibrate your sprayer using the tip and speed charts. Once you have determined the proper speed and pressure settings, you will need to consult your chemical label for the amount of chemical to be added to the tank. Read the entire label. Use only according to label directions.

Calibration

Chemical labels may show application rates in gallons per acre, gallons per 1000 square feet or gallons per 100 square feet. You will note that the tip chart shows 3 of these rating systems. Once you know how much you are going to spray, then determine (from the tip chart) the spraying pressure (PSI), and the spraying speed (MPH).

Determining the proper speed of the pulling vehicle can be done by marking off 100, 200 & 300 feet. The speed chart indicates the number of seconds it takes to travel the distances. Set the throttle and with a running start, travel the distances. Adjust the throttle until you travel the distances in the number of seconds indicated by the speed chart. Once you have reached the throttle setting needed, mark the throttle location so you can stop and go again, returning to the same speed.

Add water and proper amount of chemical to the tank and drive to the starting place for spraying.

Tip Chart for TKT-VP3, TF-VP3 & 30DT3.0 (Gray) Tips									
	Pressure (psi)	Capacity (GPM)	1 MPH	2 MPH	3 MPH	4 MPH	5 MPH	7.5 MPH	10 MPH
Gallons Per Acre Based on Water	10	.30	44	22	14.9	11.1	8.9	5.9	4.5
	20	.42	63	31.5	20.9	15.7	12.6	8.4	6.3
	30	.52	76	38	26	19.3	15.4	10.3	7.7
	40	.60	90	45	30	22	17.8	11.8	8.9
Gallons Per 1000 Sq. Ft. Based on Water	10	.30	1.01	.5	.34	.254	.204	.135	.103
	20	.42	1.4	.72	.48	.36	.29	.19	.14
	30	.52	1.74	.87	.596	.44	.35	.236	.176
	40	.60	2.06	1.00	.688	.50	.408	.27	.20
Gallons Per 100 Sq. Ft. Based on Water	10	.30	.10	.05	.034	.025	.02	.013	.01
	20	.42	.14	.072	.048	.036	.029	.019	.014
	30	.52	.174	.087	.059	.044	.035	.023	.017
	40	.60	.206	.10	.068	.05	.04	.027	.02

Speed Chart			
Speed in M.P.H. (Miles Per Hour)	Time Required in seconds to travel a distance of		
	100 Ft.	200 Ft.	300 Ft.
1.0	68 sec.	136	205
2.0	34	68	102
3.0	23	45	68
4.0	17	34	51
5.0	14	27	41
6.0	11	23	34
7.0	9.7	19	29
8.0	8.5	17	26
9.0	7.6	15	23
10.0	6.8	14	20

Using the Boom Nozzles

Four things must be considered before spraying with the boom.

1. How much chemical must be mixed in the tank.
 2. Rate of spray (gallons per acre to be sprayed).
 3. What pressure (p.s.i.) will be used.
 4. Speed traveled (mph) while spraying.
- * Refer to the chemical label to determine your chemical mixture
 - * See the tip chart to determine the pressure to be used. The chart will also show the speed used when spraying.
 - * Start the pump and open the valve to the boom nozzles.
 - * Check the spray pattern. Usually you can see the coverage better on a solid concrete surface, such as a driveway.

Maintenance During/After Spraying

Periodically check the strainer and clean the screen on your intake line.

If sprayer becomes clogged during use, discontinue use immediately. DO NOT attempt to service while chemicals are in the sprayer and power is connected.

Proper care and maintenance will prolong the life of your sprayer.

After use, drain the tank and store or dispose of chemical properly. Fill the sprayer half way with clean water. Start the pump and allow the water to pump through the entire plumbing system and nozzles. Drain and then refill half full, add the recommended amount of a good quality tank cleaner, such as FIMCO Tank Neutralizer and Cleaner. (If no tank cleaner is available, you may substitute dish soap for this step, about 1-2 oz. per gallon). But a neutralizer/cleaner should be used to thoroughly clean the system. Turn pump on and circulate through system for 15 minutes and then spray out through boom and handgun nozzles. Refill sprayer half way with clean water and repeat. Follow the chemical manufacturer's disposal instructions of all wash or rinsing water.

If boom or handgun nozzles need cleaning, remove them from the sprayer and soak in warm soapy water. Clean with a soft bristled brush or toothpick if necessary. Never use a metal object. Even the slightest damage can change the flow rate and spray distribution. Water rinse and dry the tips before storing.

WARNING: Some chemicals will damage the pump valves if allowed to soak untreated for a length of time! ALWAYS flush the pump as instructed after each use. DO NOT allow chemicals to sit in the pump for extended times of idleness. Follow the chemical manufacturer's instructions on disposal of all waste water from the sprayer.

Storing Sprayer

When sprayer is not in use, release Cam Lock Handles. This is to prevent deforming of Cam Lock Mechanism. Do not use QR bracket Cams to hold and store boom in vertical position.

Winter Storage

Prepare the sprayer for end-of-season storage by running RV antifreeze through the system. This will keep internal parts lubricated, protect against corrosion and keep the unit from freezing. *Note: RV antifreeze is non-toxic and biodegradable and generally safer for the environment than automotive antifreeze.*

Before storing your sprayer for winter or long term storage, thoroughly clean and drain it as much as possible. Then pour enough pink RV antifreeze into the tank so that when the pump is turned on you can pump the antifreeze throughout the entire plumbing system, including the bypass. Make sure to operate the boom and handgun until you see pink fluid spraying from the nozzles. Leave any remaining antifreeze in the tank. Before your next usage, rinse the antifreeze from the sprayer with clean water.

It is nearly impossible to drain all of the water from the sprayer and any trapped water can freeze in cold weather and damage parts of the sprayer. Pumping the antifreeze through the system will displace the water and help prevent this damage.

Removing from storage: drain the antifreeze. Fill the tank with fresh water and run through the system. Dispose of antifreeze and flush water properly.

Exploded View/Parts List:

ATVBK-200-QR

(5302339)

Tank Shown for Reference Only

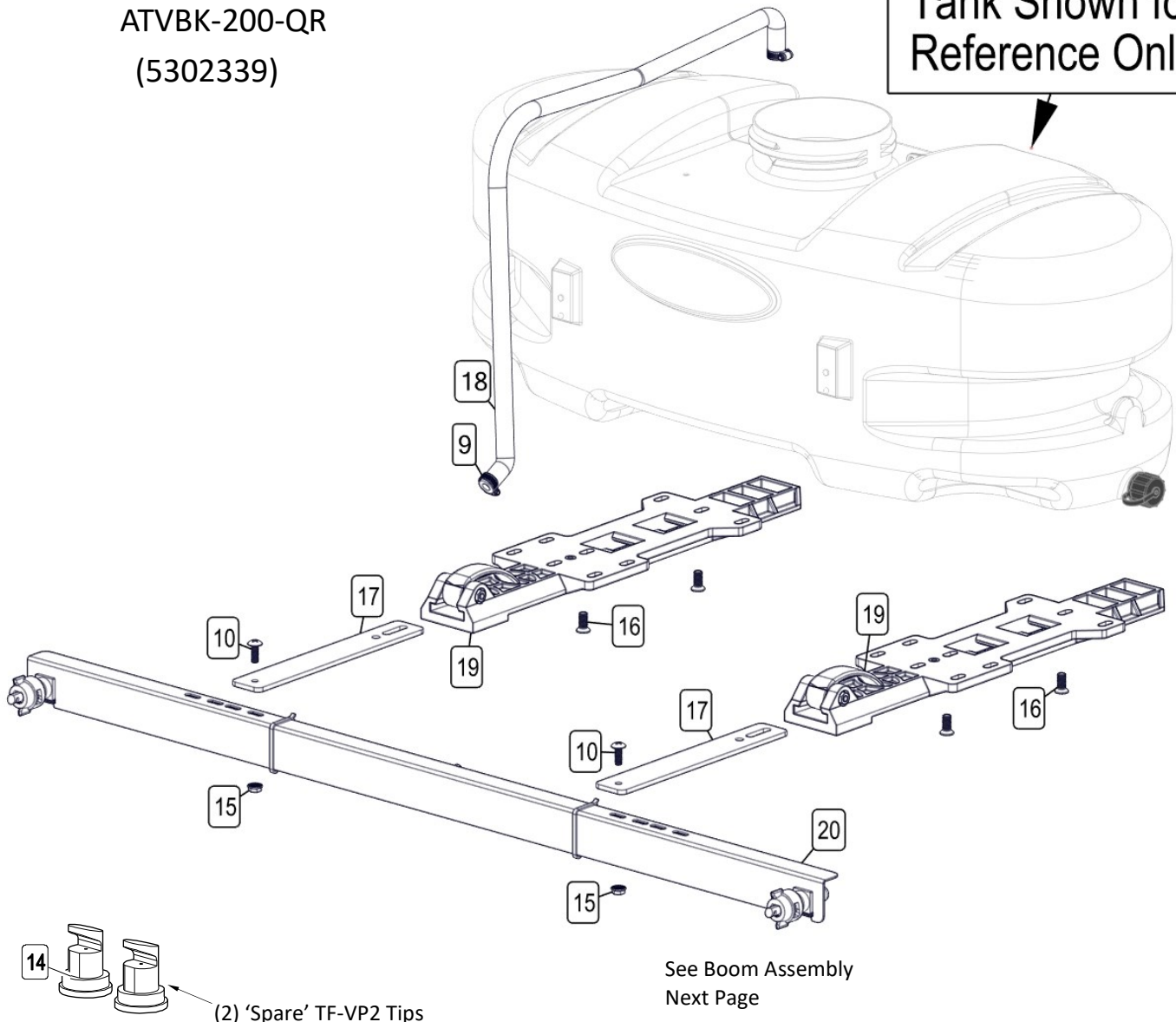

Ref. #	Part #	Description	Qty
1	5281538	Quick Connect Manifold Assembly	1
1.1	5302347	Quick Connect Manifold (Main Body)	1
1.1.1	5072514	O-Ring - Pump Port Connection	1
1.1.2	5143421	Quick Connect Manifold - Handle	2
1.2	5143430	Flat Washer - Hose Barb Seal	3
1.3	5143431	QC Manifold - 3/8" Hose Straight Barb	3
1.4	5143429	Quick Connect Quarter Turn Cap	3
2	5143422	QC Manifold - Support Bracket	1
3	5117168	#10-24 x 1" PH Truss Head Screw	1
4	5100959	Formed Bypass Tube	1
5	5075018	Grommet, 1/2" I.D.	1
6	5020532	Hose, 3/8"-1 Brd. x 7 1/4"	1
7	5075022	Grommet (5/8" I.D.)	1
8	5020343	Hose, 3/8"-1 Brd. x 2"	1
9	5051144	Hose Clamp, 3/8"	4
10	5117287	1/4"-20 x 3/4" PH Truss Head Screw	2
11	5278323	Y-Valve Assembly	1

Ref. #	Part #	Description	Qty
11.1	5067120	Poly Fitting, 3/4" MGHT x 3/8" HB	1
11.2	5143204	Dual Hose Shut-Off "Y" Valve	1
11.3	5016066	1 Inch Rubber Washer	2
11.4	5149034	Poly Swivel, 3/8" Hose Barb	2
11.5	5006209	Poly Knurled Swivel Nut, 3/4" FGHT	2
12	5167097	2" Dry 100# Back Mount Gauge	1
13	5167007	Pressure Gauge, 0-100 PSI	1
14	5018272	Turbo FloodJet Tip (TF-VP2)	2
15	5006306	1/4"-20nc Hex Flanged Whiz Nut	2
16	5034149	5/16"-18nc x 3/4" Flat Head Screw	4
17	5038874-BLK	QR Boom Mount Bracket-Fixed Height	2
18	5020538	Hose, 3/8"-1 Brd. x 43"	1
19	5278222	ATV Quick Release Bracket Assembly	2
19.1	5078223	Cam Handle Assembly	1
20	5278237	Rigid 2-Nozzle ATV Boom Assembly	1

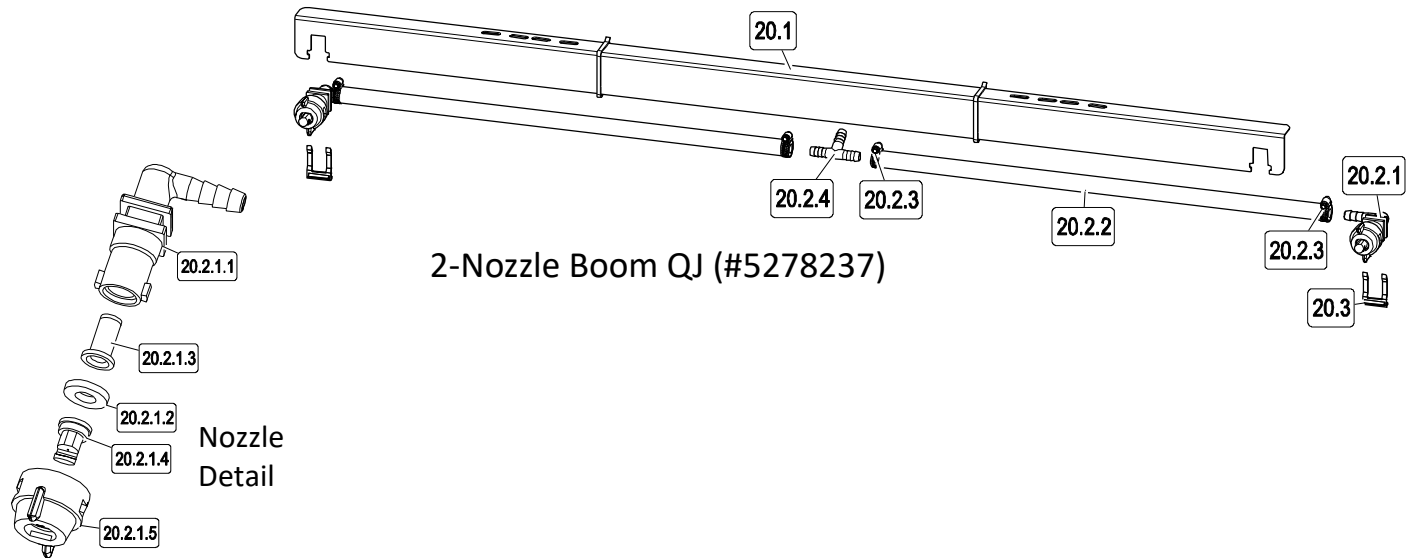

2-Nozzle Boom QJ (#5278237)

Ref. #	Part #	Description	Qty
20	5278237	Rigid 2-Nozzle ATV Boom Assembly	1
20.1	5095377-BLK	Boom Mount Angle (Quick Release)	1
20.2	5277692	2-Nozzle Harness (3/8")	1
20.2.1	5281306	ELL Nozzle Sub-Assembly (3/8")	2
20.2.1.1	5056113	Single Hose Shank (3/8" Hose)	1
20.2.1.2	5143543	Check Strainer, Blue (50 Mesh), 5 PSI	1
20.2.1.3	5016157	Seat Washer (QJ Caps)	1

Ref. #	Part #	Description	Qty
20.2.1.4	5018274	Turbo FloodJet Tip (TF-VP3)	1
20.2.1.5	5046251	QJ Cap Only (Black)	1
20.2.2	5020531	Hose, 3/8"-1 Brd. x 19-3/8" NBR & PVC	2
20.2.3	5051144	Hose Clamp, 3/8"	4
20.2.4	5086025	Poly Hose Tee, 3/8" HB	1
20.3	5053110	Plastic Retaining Clip	2

Based on the minimum overlap required to obtain uniform distribution with 120° tips and 40" spacing.

Suggested Minimum Spray Height: 18"-20" above what is being sprayed (to plant, not ground).

Optimum Spray Height: 39"

Wide angle spray nozzle height is influenced by nozzle orientation. The critical factor is to achieve a minimum 30% overlap.

Warranty

LIMITED WARRANTY FOR NEW FIMCO, IND. EQUIPMENT

WHO MAY USE THIS LIMITED WARRANTY. This limited warranty (the "Limited Warranty") is provided by Fimco, Ind. to the original purchaser ("you") of the Equipment (as defined below) from Fimco, Ind. or one of Fimco, Ind.'s authorized dealers. This Limited Warranty does not apply to any subsequent owner or other transferee of the Equipment. THIS LIMITED WARRANTY GIVES YOU SPECIFIC LEGAL RIGHTS, AND YOU MAY ALSO HAVE OTHER RIGHTS WHICH VARY FROM STATE TO STATE.

WHAT THIS LIMITED WARRANTY COVERS AND FOR HOW LONG. Fimco, Inc. warrants that any registered new Equipment will be free from defects in material and workmanship for a period of **one (1) year** (homeowner), **90 days** (commercial user), after delivery of the Equipment to you (the "Warranty Period"). The Warranty Period is not extended if Fimco, Inc. repairs or replaces the Equipment.

WHAT IS NOT COVERED BY THIS LIMITED WARRANTY. This Limited Warranty does not apply to: (1) used Equipment; (2) any Equipment that has been altered, changed, repaired or treated since its delivery to you, other than by Fimco, Ind. or its authorized dealers; (3) damage or depreciation due to normal wear and tear; (4) defects or damage due to failure to follow Fimco, Ind.'s operator's manual, specifications or other written instructions, or improper storage, operation, maintenance, application or installation of parts; (5) defects or damage due to misuse, accident or neglect, "acts of God" or other events beyond Fimco, Ind.'s reasonable control; (6) accessories, attachments, tools or parts that were not manufactured by Fimco, Ind., whether or not sold or operated with the Equipment; or (7) rubber parts, such as tires, hoses and grommets.

HOW TO OBTAIN WARRANTY SERVICE. To obtain warranty service under this Limited Warranty, you must (1) provide written notice to Fimco, Ind. of the defect during the Warranty Period and within **thirty (30)** days after the defect becomes apparent or the repair becomes necessary, at the following address: Fimco, Ind., 1000 Fimco Lane, North Sioux City, SD 57049; and (2) make the Equipment available to Fimco, Ind. or an authorized dealer within a reasonable period of time. For more information about this Limited Warranty, please call: **800-831-0027**.

WHAT REMEDIES ARE AVAILABLE UNDER THIS LIMITED WARRANTY. If the conditions set forth above are fulfilled and the Equipment or any part thereof is found to be defective, Fimco, Ind. shall, at its own cost, and at its option, either repair or replace the defective Equipment or part. Fimco, Ind. will pay for shipping and handling fees to return the repaired or replacement Equipment or part to you.

LIMITATION OF IMPLIED WARRANTIES AND OTHER REMEDIES. THE REMEDIES DESCRIBED ABOVE ARE YOUR SOLE AND EXCLUSIVE REMEDIES, AND FIMCO, IND.'S SOLE LIABILITY, FOR ANY BREACH OF THIS LIMITED WARRANTY. TO THE EXTENT APPLICABLE, ANY IMPLIED WARRANTIES, INCLUDING, WITHOUT LIMITATION, THE IMPLIED WARRANTIES OF MERCHANTABILITY AND FITNESS FOR A PARTICULAR PURPOSE, SHALL BE LIMITED IN DURATION TO THE WARRANTY PERIOD, AND THE REMEDIES AVAILABLE FOR BREACH THEREOF SHALL BE LIMITED TO THE REMEDIES AVAILABLE UNDER THIS EXPRESS LIMITED WARRANTY. SOME STATES DO NOT ALLOW LIMITATIONS ON HOW LONG AN IMPLIED WARRANTY LASTS, SO THE ABOVE LIMITATION MAY NOT APPLY TO YOU. IN NO EVENT SHALL FIMCO, IND.'S LIABILITY UNDER THIS LIMITED WARRANTY EXCEED THE ACTUAL AMOUNT PAID BY YOU FOR THE DEFECTIVE EQUIPMENT, NOR SHALL FIMCO, IND. BE LIABLE, UNDER ANY CIRCUMSTANCES, FOR ANY CONSEQUENTIAL, INCIDENTAL, SPECIAL OR PUNITIVE DAMAGES OR LOSSES, WHETHER DIRECT OR INDIRECT. SOME STATES DO NOT ALLOW THE EXCLUSION OR LIMITATION OF INCIDENTAL OR CONSEQUENTIAL DAMAGES, SO THE ABOVE LIMITATION OR EXCLUSION MAY NOT APPLY TO YOU.