

OWNER'S MANUAL

Model: BK-40A (5302290)
(4-Nozzle Boom Assembly)

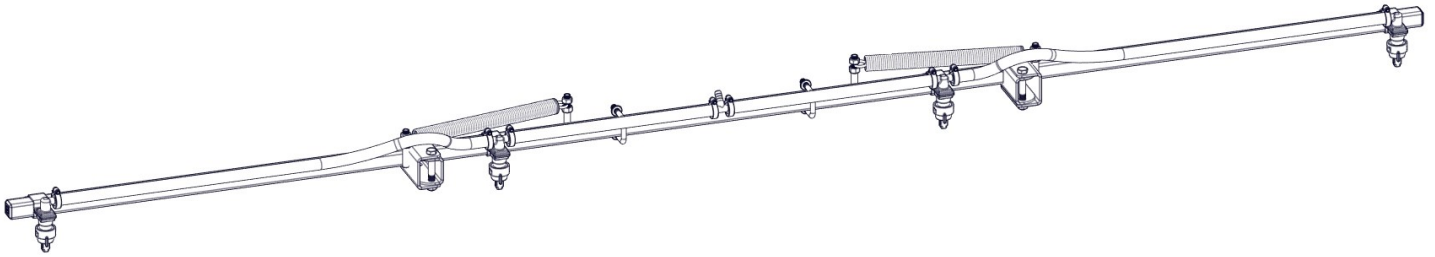

General Information

Thank you for purchasing this product. The purpose of this manual is to assist you in operating and maintaining your boom assembly.

**BEFORE RETURNING THIS PRODUCT
FOR ANY REASON, PLEASE CALL**

1-800-831-0027

MONDAY-FRIDAY, 8:00 AM TO 5:00 PM CST

If you should have a question or experience a problem with your Fimco Industries Product: Visit our website @ www.fimcoindustries.com or call the Toll free number above. Our technical support representatives will be happy to help you.

In most cases a customer service rep. can resolve the problem over the phone.

To obtain prompt, efficient service, always remember to give the following information....

- Correct Part Description and/or part number
- Model number and Serial Number

Part descriptions and numbers can be obtained from the illustrated parts list section(s) of this manual.

Retain a copy of your receipt for your unit, as it will be required to validate any warranty service.

Warranted against manufacturer or workmanship defects from date of purchase with copy of receipt:

Homeowner Usage: One Year.

Commercial Usage: 90 Days.



WARNING: To reduce the risk of injury, the user must read and understand the operator's manual before using this product.



WARNING: Cancer and Reproductive Harm.
www.P65Warnings.ca.gov



www.fimcoindustries.com

1000 FIMCO Lane, P.O. Box 1700, North Sioux City, SD 57049
Toll Free Phone: 800-831-0027 : Toll Free Fax: 800-494-0440
[5008407 (11/22)]

Contents

Technical Specs.....	2	Maintenance	4
Assembly Instructions.....	2	Winter Storage	4
Operation.....	3	Boom Exploded View/Parts List	5
Calibration	3	Warranty	6

Model: BK-40A (5302290)

(4-Nozzle Boom Assembly)

Technical Specifications

- 4-Nozzle Boom Assembly
- Break-Away Outer Booms
 - 120" of Spray Coverage
- AIXR11002 VP, #2 (Yellow) 110° tips
- Check Valve Strainers, 50 Mesh, 5 PSI

This boom weighs approx. 17 Lbs.

Always check the vehicle load rating before using a boom with sprayer, ensuring total weight is acceptable.

Do not exceed the recommended rating.

IMPORTANT

It is VERY important to test the sprayer, after attaching any boom with plain water before actual spraying is attempted. This will enable you to familiarize yourself with the sprayer and check for leaks without the possibility of losing any expensive chemicals.

WARNING



Read and Understand the Owner's Manual before using this boom. Test and use in accordance to instructions.

Read and Follow chemical label instructions and wear protective gear when filling, using, cleaning and servicing the boom.

Exercise Caution in vehicle handling when towing/hauling a filled sprayer to avoid loss of control or overturning.

Keep Sprayer and Spray materials away from other people, children and pets.

Do Not Turn on Power to the sprayer, until ready to spray in order to avoid unintentional spray release.

Do Not Use on steep slopes. A full sprayer could cause loss of control or overturn sprayer and vehicle.

Always operate up and down a slope, never across the face of a slope.

Keep all movement on slopes slow and gradual. Do not make sudden changes in speed, directions or turning. Do not start or stop suddenly when going uphill or downhill.

Stop on level ground, set the parking brake and shut off engine before leaving the operator's position for any reason.

Keep all parts in good condition and properly installed. Fix damaged or worn parts immediately.

Caution should be taken when towing and/or using any sprayer. The sprayer combined with the weight distribution, turning radius and speed of vehicle can result in damage to vehicle, sprayer and/or boom or severe injury or death, if not used properly.

Improper use or handling of chemicals could result in serious injury or illness, or could cause damage to the environment.

Assembly Instructions

Remove the parts to the boom assembly from the carton. Refer to the parts list and exploded view drawing to help identify all the components.

1. Center the center section of the boom onto your boom mounts and secure in place. Be sure that the outer booms will fold 'backwards'. The boom should be a minimum of 18" above the ground.
2. Attach the nozzle harness assembly to the boom. The end boom members should fold towards the rear of the sprayer.
3. Route your boom feeder hose under or over the unit, to the back end of the sprayer. Join the hose to the 'TEE fitting'. Then clamp in place with a hose clamp.

- Make sure all hose clamps are tight before testing or spraying for the first time.
- Your boom should be ready for operation.

After assembling, sprayer will be ready to TEST w/plain water before actual use.

Testing the Sprayer

NOTE: It is VERY important to test the sprayer, after attaching any boom with plain water before actual spraying is attempted. This will enable you to familiarize yourself with the sprayer and check for leaks without the possibility of losing any expensive chemicals.

Fill the tank about 1/2 full with plain water. When you are ready to spray, turn the boom valve to the “on” position. This will start solution spraying from the tips of the boom. The pressure will decrease slightly when the boom is spraying. Adjust the pressure by turning the “ON/OFF” valve lever on the bypass line valve. Make sure your pattern is sufficient. You may down-pressure the system by ‘bypassing’ solution back into the tank. This is achieved by opening the bypass valve. Regulating pressure is done in this manner.

Read the operating instructions and initially begin spraying by closing the ‘bypass’ valve and opening the boom line valve. This will enable the air in the line to be eliminated (purged) through all the tips, while building pressure. When everything tests all right (no leaks and good pressure), add the desired chemicals to the mixture and water combination and start your spraying operation.

Conditions of weather and terrain must be considered when setting the sprayer. Do not spray on windy days. Protective clothing must be worn in some cases

Be sure to read the chemical label(s) before application!

Operation

Fill the tank part way with water and then add the desired amount of chemical to be sprayed. Finish filling tank to proper level.

Only fill the tank with what you’re going to spray in a day, never leave chemicals sit in tank.

When spraying with either the boom or the handgun, pressure may be reduced by slowly opening the bypass valve until desired pressure is achieved. Opening the valve decreases pressure, closing the valve increases pressure. When spraying with the boom, the proper method to set the pressure is to open the boom valve completely and if a lower pressure is desired, then slowly open the bypass valve until that pressure is obtained.

For the safest and most efficient chemical application, you will need to calibrate your sprayer using the tip and speed charts. Once you have determined the proper speed and pressure settings, you will need to consult your chemical label for the amount of chemical to be added to the tank. Read the entire label. Use only according to label directions.

Calibration

Chemical labels may show application rates in gallons per acre, gallons per 1000 square feet or gallons per 100 square feet. You will note that the tip chart shows 2 of these rating systems. Once you know how much you are going to spray, then determine (from the tip chart) the spraying pressure (PSI), and the spraying speed (MPH).

Determining the proper speed of the pulling vehicle can be done by marking off 100, 200 & 300 feet. The speed chart indicates the number of seconds it takes to travel the distances. Set the throttle and with a running start, travel the distances. Adjust the throttle until you travel the distances in the number of seconds indicated by the speed chart. Once you have reached the throttle setting needed, mark the throttle location so you can stop and go again, returning to the same speed.

Add water and proper amount of chemical to the tank and drive to the starting place for spraying.

	Pressure (psi)	Capacity (GPM)	1 MPH	2 MPH	3 MPH	4 MPH	5 MPH	6 MPH
Gallons Per Acre Based on Water	15	.12	23.50	11.70	7.80	5.90	4.70	3.90
	20	.14	27.50	13.70	9.10	6.90	5.50	4.60
	30	.17	33.30	16.60	11.10	8.30	6.70	5.50
	40	.20	39.30	19.70	13.10	9.80	7.90	6.50
Gallons Per 1000 Sq. Ft. Based on Water	15	.12	.54	.27	.18	.13	.11	
	20	.14	.64	.32	.21	.16	.13	
	30	.17	.76	.38	.26	.19	.15	
	40	.20	.90	.45	.30	.22	.18	

Speed in M.P.H. (Miles Per Hour)	Time Required in seconds to travel a distance of		
	100 Ft.	200 Ft.	300 Ft.
1.0	68 sec.	136	205
2.0	34	68	102
3.0	23	45	68
4.0	17	34	51
5.0	14	27	41
6.0	11	23	34

Using the Boom Nozzles

Four things must be considered before spraying with the boom.

1. How much chemical must be mixed in the tank.
 2. Rate of spray (gallons per acre to be sprayed).
 3. What pressure (PSI) will be used.
 4. Speed traveled (MPH) while spraying.
- * Refer to the chemical label to determine your chemical mixture
 - * See the tip chart to determine the pressure to be used. The chart will also show the speed used when spraying.
 - * Start the pump and open the valve to the boom nozzles.
 - * Check the spray pattern. Usually you can see the coverage better on a solid concrete surface, such as a driveway.
 - * Raise or lower the nozzles so that you will have a good coverage pattern. Generally the proper height will be about 18 inches from the object(s) being sprayed.

Maintenance During/After Spraying

Periodically check the strainer on the sprayer and clean the screen on your intake line.

If sprayer becomes clogged during use, discontinue use immediately. DO NOT attempt to service while chemicals are in the sprayer and power is connected.

Proper care and maintenance will prolong the life of your sprayer.

After use, drain the tank and store or dispose of chemical properly. Fill the sprayer half way with clean water. Start the pump and allow the water to pump through the entire plumbing system and nozzles. Drain and then refill half full, add the recommended amount of a good quality tank cleaner, such as FIMCO Tank Neutralizer and Cleaner. (If no tank cleaner is available, you may substitute dish soap for this step, about 1-2 oz. per gallon). But a neutralizer/cleaner should be used to thoroughly clean the system. Turn pump on and circulate through system for 15 minutes and then spray out through boom and handgun nozzles. Refill sprayer half way with clean water and repeat. Follow the chemical manufacturer's disposal instructions of all wash or rinsing water. Remove the tips and screens from the nozzle assemblies. Wash these items out thoroughly. Blow the orifice clean and dry. If the orifice remains clogged, clean it with a fine bristle (NOT WIRE) brush or with a toothpick. Do not damage the orifice. Water rinse and dry the tips before storing.

WARNING: Some chemicals will damage the pump valves if allowed to soak untreated for a length of time! ALWAYS flush the pump as instructed after each use. DO NOT allow chemicals to sit in the pump for extended times of idleness. Follow the chemical manufacturer's instructions on disposal of all waste water from the sprayer.

CAUTION: Never use a metal object or other sharp item for cleaning a nozzle tip. It is better to use a nozzle brush (NOT wire brush) or compressed air for tip cleaning.

Winter Storage

It is essential that you winterize your sprayer to avoid damage and to allow for optimal performance. The winterization process should be undertaken before freezing conditions and/or after each season of use.

Before storing your sprayer for winter or long term storage, thoroughly clean and drain it as much as possible. Then pour enough antifreeze into the tank so that when the pump is turned on you can pump the antifreeze throughout the entire plumbing system, including the bypass. Make sure to operate the boom and handgun until you see fluid spraying from the nozzles. Leave any remaining antifreeze in the tank. Before your next usage, rinse the antifreeze from the sprayer with clean water.

It is nearly impossible to drain all of the water from the sprayer and any trapped water can freeze in cold weather and damage parts of the sprayer. Pumping the antifreeze through the system will displace the water and help prevent this damage.

1. Verify that the tank is empty and rinsed out. Pour 1-2 gallons of antifreeze into the tank.
 - A. 12-Volt Pump, use pink RV Antifreeze through the system. This will keep internal parts lubricated, protect against corrosion and keep the unit from freezing.
Note: RV antifreeze is non-toxic and biodegradable and generally safer for the environment than automotive antifreeze.
 - B. Roller Pump, use a solution of automotive antifreeze (containing a rust inhibitor) through the entire plumbing system.
2. Engage the pump and spray with the boom and spray gun (if applicable). Make sure that the antifreeze has been pumped through the entire system, including all spray nozzles.
3. Before spraying in the spring, it is recommended to flush the sprayer with fresh water to cleanse it of the antifreeze and any other buildup. It would also be beneficial to do a thorough inspection of all sprayer components before spraying.

Removing from storage: drain the antifreeze. Fill the tank with fresh water and run through the system. Dispose of antifreeze and flush water properly.

Opposite side has typical hardware setup

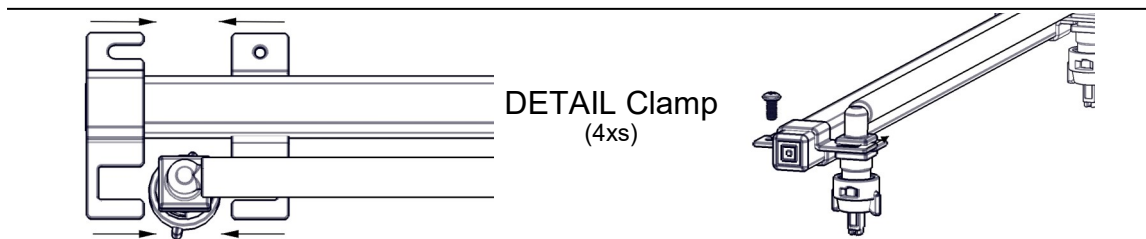
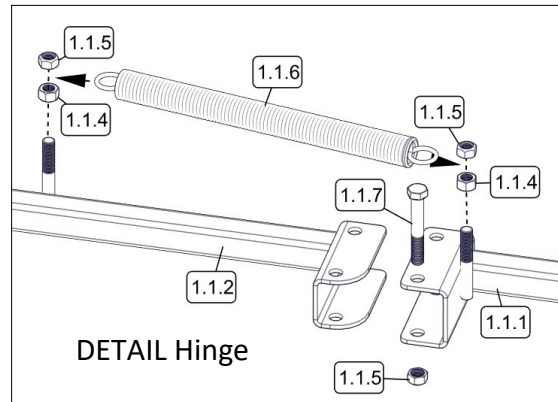
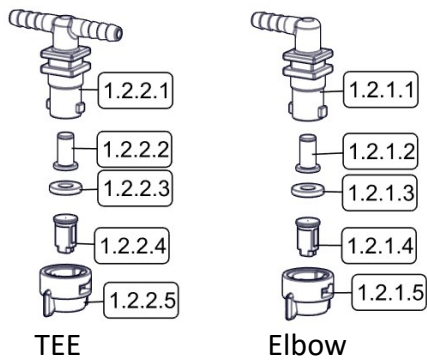
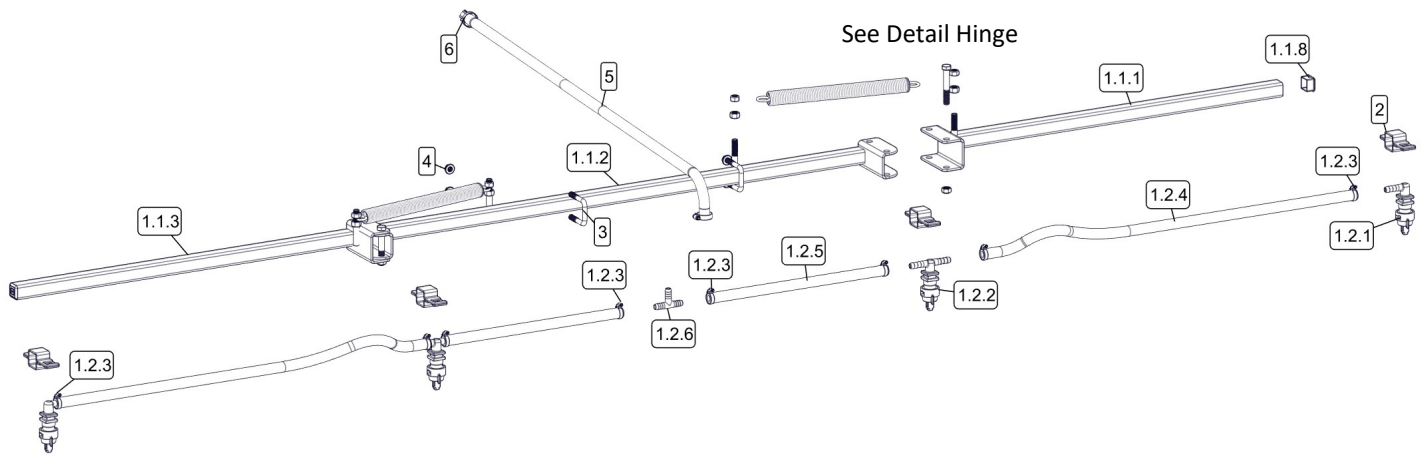

Exploded View/Parts List: BK-40A (5302290)

Ref. #	Part #	Description	Qty
1	5302290	4 Nozzle Boom Assembly	1
1.1	5277778	4-Nozzle Boom Only	1
1.1.1	5277833-BLK	Outer Boom 1" Sq. Tube R.H.	1
1.1.2	5277831-BLK	Center Boom 1" Sq. Tube	1
1.1.3	5277832-BLK	Outer Boom 1" Sq. Tube L.H.	1
1.1.4	5006259	3/8"-16, 11/16" Hex Nut	4
1.1.5	5006345	3/8"-16 Hex Locknut	6
1.1.6	5019228	Extension Spring	2
1.1.7	5034169	H.H.C.S., 3/8"-16 x 2 1/2"	2
1.1.8	5046106	Square Cap, Black (1" Square Tube)	2
1.2	5277694	4-Nozzle Harness (3/8")	1
1.2.1	5281304	"ELL" Nozzle Sub-Assembly (3/8")	2
1.2.1.1	5056113	Single Hose Shank (3/8" Hose)	1
1.2.1.2	5143543	Check Valve Strainer, 50 Mesh, 5 PSI	1
1.2.1.3	5016157	Seat Washer (QJ Caps)	1
1.2.1.4	5018371	Air-Induction XR Flat Spray Tip	1
1.2.1.5	5046219	Quick TeeJet Cap ONLY (Yellow)	1

Ref. #	Part #	Description	Qty
1.2.2	5281307	"TEE" Nozzle Sub-Assembly (3/8")	2
1.2.2.1	5056114	Double Hose Shank (3/8" Hose)	1
1.2.2.2	5143543	Check Valve Strainer, 50 Mesh, 5 PSI	1
1.2.2.3	5016157	Seat Washer (QJ Caps)	1
1.2.2.4	5018371	Air-Induction XR Flat Spray Tip	1
1.2.2.5	5046219	Quick TeeJet Cap ONLY (Yellow)	1
1.2.3	5051144	Hose Clamp - 3/8"	8
1.2.4	5020523	Hose, 3/8"-1 Brd. x 31"	2
1.2.5	5020522	Hose, 3/8"-1 Brd. x 13-3/4"	2
1.2.6	5086025	Poly Hose Tee, 3/8" HB	1
2	5272164	Vari-Quick Clamp (1" Sq. Tube)	4
3	5034159	Square U-Bolt, 5/16" x 1 5/16" x 1 7/8"	2
4	5006307	5/16"-18 Hex Whiz (Flange) Locknut	4
5	5020514	Hose, 3/8"-1 Brd. x 43"	1
6	5051144	Hose Clamp - 3/8"	2

Based on the minimum overlap required to obtain uniform distribution with 110° tips and 30" spacing.
Suggested Minimum Spray Height: 20"-22" above what is being sprayed (to plant, not ground).
Optimum Spray Height: 20"

- 110° wide, tapered flat spray angle with air induction technology for better drift management
- Made of 2-piece UHMWPE polymer construction which provides excellent chemical resistance, including acids, as well as exceptional wear life
- Compact size to prevent tip damage
- Excellent for systemic products and drift management

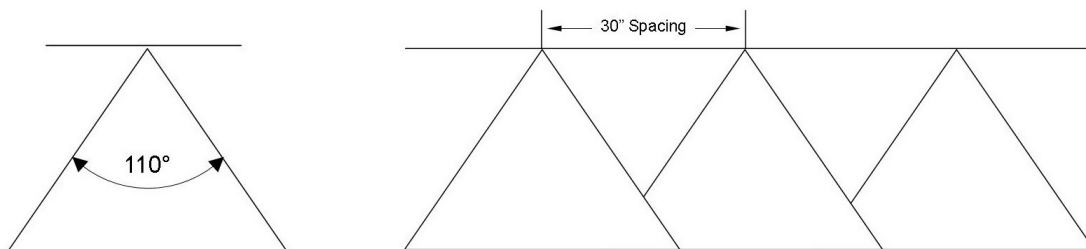

Warranty

LIMITED WARRANTY FOR NEW FIMCO, IND. EQUIPMENT

WHO MAY USE THIS LIMITED WARRANTY. This limited warranty (the "Limited Warranty") is provided by Fimco, Ind. to the original purchaser ("you") of the Equipment (as defined below) from Fimco, Ind. or one of Fimco, Ind.'s authorized dealers. This Limited Warranty does not apply to any subsequent owner or other transferee of the Equipment. THIS LIMITED WARRANTY GIVES YOU SPECIFIC LEGAL RIGHTS, AND YOU MAY ALSO HAVE OTHER RIGHTS WHICH VARY FROM STATE TO STATE.

WHAT THIS LIMITED WARRANTY COVERS AND FOR HOW LONG. Fimco, Ind. warrants that any new Equipment will be free from defects in material and workmanship for a period of **one (1) year** (homeowner), **90 days** (commercial user), after delivery of the Equipment to you (the "Warranty Period"). The Warranty Period is not extended if Fimco, Ind. repairs or replaces the Equipment.

WHAT IS NOT COVERED BY THIS LIMITED WARRANTY. This Limited Warranty does not apply to: (1) used Equipment; (2) any Equipment that has been altered, changed, repaired or treated since its delivery to you, other than by Fimco, Ind. or its authorized dealers; (3) damage or depreciation due to normal wear and tear; (4) defects or damage due to failure to follow Fimco, Ind.'s operator's manual, specifications or other written instructions, or improper storage, operation, maintenance, application or installation of parts; (5) defects or damage due to misuse, accident or neglect, "acts of God" or other events beyond Fimco, Ind.'s reasonable control; (6) accessories, attachments, tools or parts that were not manufactured by Fimco, Ind., whether or not sold or operated with the Equipment; or (7) rubber parts, such as tires, hoses and grommets.

HOW TO OBTAIN WARRANTY SERVICE. To obtain warranty service under this Limited Warranty, you must (1) provide written notice to Fimco, Ind. of the defect during the Warranty Period and within **thirty (30) days** after the defect becomes apparent or the repair becomes necessary, at the following address: Fimco, Ind., 1000 Fimco Lane, North Sioux City, SD 57049; and (2) make the Equipment available to Fimco, Ind. or an authorized dealer within a reasonable period of time. For more information about this Limited Warranty, please call: **800-831-0027**.

WHAT REMEDIES ARE AVAILABLE UNDER THIS LIMITED WARRANTY. If the conditions set forth above are fulfilled and the Equipment or any part thereof is found to be defective, Fimco, Ind. shall, at its own cost, and at its option, either repair or replace the defective Equipment or part. Fimco, Ind. will pay for shipping and handling fees to return the repaired or replacement Equipment or part to you.

LIMITATION OF IMPLIED WARRANTIES AND OTHER REMEDIES. THE REMEDIES DESCRIBED ABOVE ARE YOUR SOLE AND EXCLUSIVE REMEDIES, AND FIMCO, IND.'S SOLE LIABILITY, FOR ANY BREACH OF THIS LIMITED WARRANTY. TO THE EXTENT APPLICABLE, ANY IMPLIED WARRANTIES, INCLUDING, WITHOUT LIMITATION, THE IMPLIED WARRANTIES OF MERCHANTABILITY AND FITNESS FOR A PARTICULAR PURPOSE, SHALL BE LIMITED IN DURATION TO THE WARRANTY PERIOD, AND THE REMEDIES AVAILABLE FOR BREACH THEREOF SHALL BE LIMITED TO THE REMEDIES AVAILABLE UNDER THIS EXPRESS LIMITED WARRANTY. SOME STATES DO NOT ALLOW LIMITATIONS ON HOW LONG AN IMPLIED WARRANTY LASTS, SO THE ABOVE LIMITATION MAY NOT APPLY TO YOU. IN NO EVENT SHALL FIMCO, IND.'S LIABILITY UNDER THIS LIMITED WARRANTY EXCEED THE ACTUAL AMOUNT PAID BY YOU FOR THE DEFECTIVE EQUIPMENT, NOR SHALL FIMCO, IND. BE LIABLE, UNDER ANY CIRCUMSTANCES, FOR ANY CONSEQUENTIAL, INCIDENTAL, SPECIAL OR PUNITIVE DAMAGES OR LOSSES, WHETHER DIRECT OR INDIRECT. SOME STATES DO NOT ALLOW THE EXCLUSION OR LIMITATION OF INCIDENTAL OR CONSEQUENTIAL DAMAGES, SO THE ABOVE LIMITATION OR EXCLUSION MAY NOT APPLY TO YOU.