

# OWNER'S MANUAL

**Model: LG-8-P (5302164)**  
(8 Gallon Super Spot Sprayer)

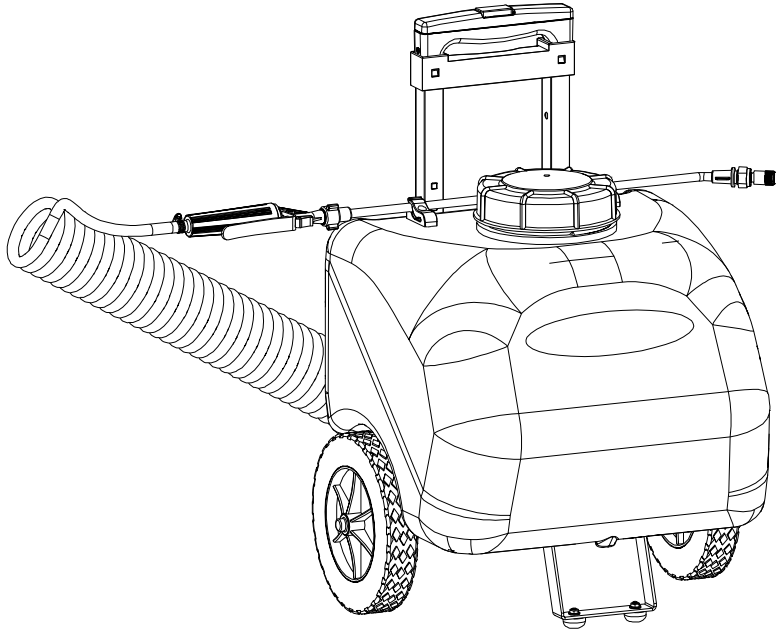

## General Information

Thank you for purchasing this product. The purpose of this manual is to assist you in operating and maintaining your lawn & garden spot sprayer.

**BEFORE RETURNING THIS PRODUCT  
FOR ANY REASON, PLEASE CALL**

**1-800-831-0027**

MONDAY-FRIDAY, 8:00 AM TO 5:00 PM CST

If you should have a question or experience a problem with your Fimco Industries Product: Visit our website @ [www.fimcoindustries.com](http://www.fimcoindustries.com) or call the Toll free number above. Our technical support representatives will be happy to help you.

In most cases a customer service rep. can resolve the problem over the phone.

To obtain prompt, efficient service, always remember to give the following information....

- Correct Part Description and/or part number
- Model number and Serial Number

Part descriptions and numbers can be obtained from the illustrated parts list section(s) of this manual.

**Retain a copy of your receipt for your unit, as it will be required to validate any warranty service.**

**Warranted against manufacturer or workmanship defects from date of purchase with copy of receipt:**



**Homeowner Usage: Sprayer-One Year and Pump-Two Years.**

**Commercial Usage: Sprayer and Pump-90 Days.**



**WARNING:** Cancer and Reproductive Harm.  
[www.P65Warnings.ca.gov](http://www.P65Warnings.ca.gov)



**WARNING:** To reduce the risk of injury, the user must read and understand the operator's manual before using this product.



[www.fimcoindustries.com](http://www.fimcoindustries.com)

1000 FIMCO Lane, P.O. Box 1700, North Sioux City, SD 57049  
Toll Free Phone: 800-831-0027 : Toll Free Fax: 800-494-0440

[5194790

(10/22)]

## Contents

Technical Specs and Table of Contents .....	2	Pump Exploded View and Parts List .....	4
Assembly Instructions .....	2	Troubleshooting .....	4 - 5
Battery Charging .....	3	Sprayer Exploded View/Parts List .....	6
Operation and Maintenance .....	3	Dimensions .....	7
Tank Care and Winter Storage .....	3	Warranty .....	8

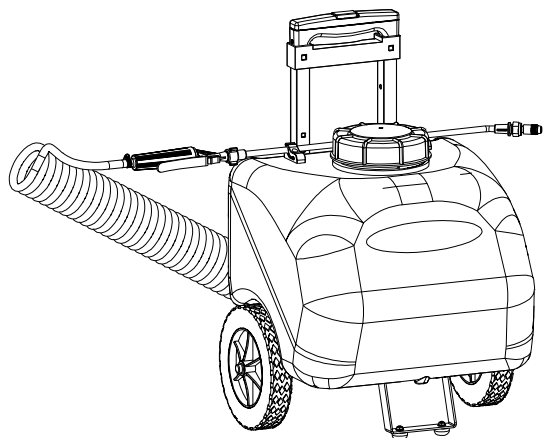

## Model: LG-8-P (5302164) (8 Gallon Super Spot Sprayer)

### Technical Specifications

- 8 Gallon Corrosion-Resistant Polyethylene Tank
- 12 Volt Diaphragm Pump, 1.2 GPM - 60 PSI
- Rechargeable 12V Battery (AC Charger Included)
- Lever Handgun with 15' Coiled Hose
- 25 Ft. Horizontal Throw, 12 Ft. Vertical Throw
- 8" Wheels
- Telescopic Handle for Easy Mobility & Storage
- **Unit height with handle Extended = approx.: 37"**
- **Unit height with handle Retracted = approx.: 22"**

**Caution: Always check the vehicle load rating before using the sprayer.**  
**The loaded weight of this sprayer is approx.: 95 lbs. when the tank is full.**

### ~~~~~IMPORTANT~~~~~

Remove tank lid and be sure the tank is clean and free of any foreign material. Rinse tank out of any tank residue before filling with water to test.

### ~~~~~IMPORTANT~~~~~

It is VERY important to test this sprayer with plain water before actual spraying is attempted. This will enable you to check the sprayer for leaks without the possibility of losing any expensive chemicals.

### ~~~~~WARNING~~~~~



**Read and Understand** the Owner's Manual before using this sprayer. Test and use in accordance to instructions.  
**Read and Follow** chemical label instructions and wear protective gear when filling, using, cleaning and servicing the sprayer.

**Exercise Caution** in vehicle handling when towing/hauling a filled sprayer to avoid loss of control or overturning.

**Keep Sprayer and Spray materials** away from other people, children and pets.

**Do Not Turn on Power** to the sprayer, until ready to spray in order to avoid unintentional spray release.

**Do Not Use** on steep slopes. A full sprayer could cause loss of control or overturn sprayer and vehicle.

**Always operate** up and down a slope, never across the face of a slope.

**Keep all movement on slopes** slow and gradual. Do not make sudden changes in speed, directions or turning. Do not start or stop suddenly when going uphill or downhill.

**Stop on level ground**, set the parking brake and shut off engine before leaving the operator's position for any reason.

**Keep all parts** in good condition and properly installed. Fix damaged or worn parts immediately.

**Caution should be taken** when towing and/or using any sprayer. This sprayer combined with the weight distribution, turning radius and speed of vehicle can result in damage to vehicle and/or sprayer or severe injury or death, if not used properly.

**Improper use of this sprayer or handling of chemicals could result in serious injury or illness, or could cause damage to the environment.**

## Assembly Instructions

This unit is mostly assembled at the factory.

You may need to attach the barrel of the handgun onto the trigger assembly, as this may be disassembled to fit into the box.

Make sure all hose clamps are tight before testing or spraying for the first time.

**\*\*The Sprayer is now ready to TEST w/plain water before actual use\*\***

**IMPORTANT:** Remove tank lid and be sure the tank is clean and free of any foreign material. Rinse tank out of any tank residue before filling with water to test.

### **Battery Charging**

It is a good idea to charge the battery for 8-10 hours before using the sprayer, especially if you plan to spray for a long period of time, this will insure that the battery is fully charged.

Charging the battery may be done as follows:

1. Plug the charger into a 110 Volt AC electric receptacle
2. Insert the plug (which is molded onto the end of the charger wire) into the jack, which is located on the rear of the sprayer.
3. Disconnect the plug from the jack and the charger from the electrical outlet when the charging operation is complete.

**CAUTION:** Do not leave the charger connected to the battery for longer than 20 hours, as it may cause premature battery failure.

### **Testing the Sprayer**

**NOTE:** It is important to test this sprayer for leakage with plain water before chemical application is attempted. This will also give you the opportunity to familiarize yourself with the operation of the sprayer, without the possibility of losing any expensive chemicals.

Fill the tank about 1/2 full of plain water for testing.

Conditions of weather and terrain must be considered when setting the sprayer. Do not spray on windy days. Protective clothing must be worn in some cases

**Be sure to read the chemical label(s) before application!**

### **Operation**

The pumping system draws solution from the tank, through the strainer and to the pump. The pump forces the solution under pressure to the handgun nozzle.

Fill the container with solution (water and chemical), then stir to mix. Mixing can also be done by sticking the handgun nozzle into the container and spray into the solution.

**Only fill the tank with what you're going to spray in a day, never leave chemicals sit in tank.**

Turn the switch to "ON" and squeeze the lever on the handgun to spray.

NOTE: The pump is equipped with a pressure switch that is pre-set at the factory to shut the pump off when all discharges are closed.

The pump will turn back on when the handgun is activated, by squeezing the handle lever.

- Rotating the adjustable nozzle tip on the handgun will change the tip pattern from a straight stream to a cone pattern (fine mist)

### **Maintenance During/After Spraying**

Periodically check the strainer and clean the screen on your intake line.

If sprayer becomes clogged during use, discontinue use immediately. DO NOT attempt to service while chemicals are in the sprayer and power is connected.

Proper care and maintenance will prolong the life of your sprayer.

After use, drain the tank and store or dispose of chemical properly. Fill the sprayer half way with clean water. Start the pump and allow the water to pump through the entire plumbing system and spray gun nozzle. Drain and then refill half full, add the recommended amount of a good quality tank cleaner, such as FIMCO Tank Neutralizer and Cleaner. (If no tank cleaner is available, you may substitute dish soap for this step, about 1-2 oz. per gallon). But a neutralizer/cleaner should be used to thoroughly clean the system. Turn pump on and circulate through system for 15 minutes and then spray out through spray gun nozzle. Refill sprayer half way with clean water and repeat. Follow the chemical manufacturer's disposal instructions of all wash or rinsing water.

If spray gun nozzle needs cleaning, remove from the sprayer and soak in warm soapy water. Clean with a soft bristled brush or toothpick if necessary. Never use a metal object. Even the slightest damage can change the flow rate and spray distribution. Water rinse and dry the tips before storing.

**WARNING:** Some chemicals will damage the pump valves if allowed to soak untreated for a length of time! ALWAYS flush the pump as instructed after each use. DO NOT allow chemicals to sit in the pump for extended times of idleness. Follow the chemical manufacturer's instructions on disposal of all waste water from the sprayer.

### Tank Care & Maintenance

**Warning:** Do not use the tank as a container for fuel oils, kerosene, gasoline or any other petroleum distillate product. All polyolefins are softened and permeated by such products. In an enclosed area the vaporization of these materials from the outside surface of the tank could create a dangerous condition.

The tank should not be used as a pressure vessel nor used with chemicals or solutions having a weight of more than 12 pounds per gallon.

Store the tank in a dry dark place when not in use. Storage out of sunlight will prolong the life of the tank.

Do not drop, strike or kick the tank, especially at low temperatures. Tanks become brittle and are subject to cracking at temperatures below 20° Fahrenheit.

Always flush the tank with water and a neutralizing agent at the end of each use, to prevent contamination of solutions.

### Winter Storage

Prepare the sprayer for end-of-season storage by running RV antifreeze through the system. This will keep internal parts lubricated, protect against corrosion and keep the unit from freezing. *Note: RV antifreeze is non-toxic and biodegradable and generally safer for the environment than automotive antifreeze.*

Before storing your sprayer for winter or long term storage, thoroughly clean and drain it as much as possible. Then pour enough pink RV antifreeze into the tank so that when the pump is turned on you can pump the antifreeze throughout the entire plumbing system, including the bypass. Make sure to operate the handgun until you see pink fluid spraying from the nozzle. Leave any remaining antifreeze in the tank. Before your next usage, rinse the antifreeze from the sprayer with clean water.

It is nearly impossible to drain all of the water from the sprayer and any trapped water can freeze in cold weather and damage parts of the sprayer. Pumping the antifreeze through the system will displace the water and help prevent this damage.

Removing from storage: drain the antifreeze. Fill the tank with fresh water and run through the system. Dispose of antifreeze and

**STOP WARNING STOP**  
DO NOT USE PUMP IN AN EXPLOSIVE ENVIRONMENT. DO NOT USE TO PUMP FLAMMABLE/COMBUSTIBLE FLUIDS, GASOLINE, KEROSENE, FUEL, OIL, ETC.

**HIGH-FLO**  
HIGH PERFORMANCE

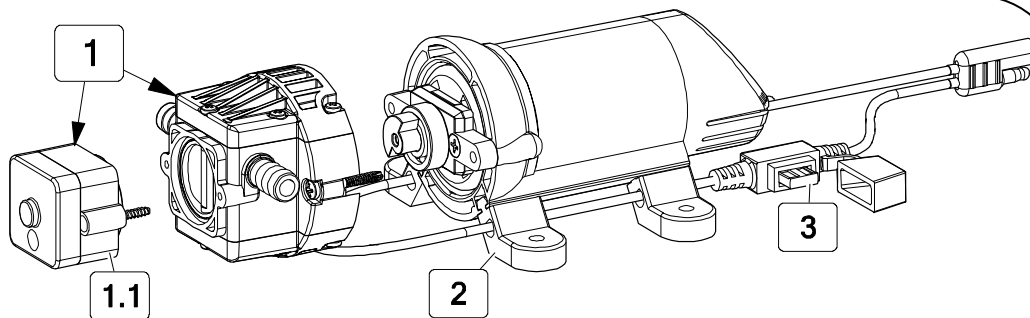

Pump Model: 5281370  
1.2 GPM - 60 PSI  
Available Replacement Parts  
Replacement Pump: 5151086

Ref. #	Part #	Description	Qty
1	5164272	1.2 GPM Pump Head	1
1.1	5164271	60 PSI Pressure Switch Assembly	1
2	5095202	Pump Mount Feet (4 Pack)	1
3	5157204	5 Amp 'Mini Blade' Fuse	1



- Clean and rinse your pump after each use with Fimco Tank Neutralizer.
- Winterize your pump or sprayer by rinsing, draining and running RV Antifreeze through it before storing for the winter.
- Use clean water for your spray mixture.
- Store inside a building when not in use.



- Use to pump bleach.
- Use to pump petroleum products such as diesel fuel, gasoline or kerosene.
- Use to pump chemicals w/petroleum distillates or surfactants.
- Leave your pump sit with spray mixture in it for extended periods.
- Use dirty or unfiltered water for spraying.

**CAUTION**

**PRESSURE SWITCH OPERATION**  
Pressure switch is pre-set at the factory. Improper adjustment of the pressure, may cause severe overload or premature failure. If pump is subjected to rapid cycling during normal operations or infrequent periods, damage may occur.

**Before Troubleshooting or Attempting to Service the Pump:**

- ◆ **Review Troubleshooting Chart:** Do Not attempt to repair until steps below are followed.
- ◆ **Personal Protective Gear:** Wear protective gear when servicing pump.
- ◆ **Disconnect Power:** Disconnect the power to the pump and relieve the pressure from the system.
- ◆ **Empty and Flush** the pump system with water, never attempt to service the pump until it has been emptied and flushed.
- ◆ **Perform Repairs:** Follow directions provided in the troubleshooting section to repair the pump.
- ◆ **Test:** Always test the pump for leaks with plain water after any repairs before using.

Troubleshooting	
Pump will not run:	Check for loose wiring
	Make sure the ON/OFF switch is on
	Check the fuse
	Check for defective pressure switch
	Check to see if connected to good 12 Volt Power Source
	Check for Low Voltage
Pump Does Not Prime (No Discharge w/Motor Running)	Check for clogged strainer/filter
	Check for kinked inlet/outlet hoses
	Check for empty product supply
	Check for cracks in the pump housing
	Check for air leaks in supply line
Low Pressure/ Low Flow:	Check for a clogged strainer
	Check for proper voltage Try another 12-Volt battery
	Check for leaks in the discharge line
	Check for restrictions in the discharge line
	Check for debris in intake
	Check for debris in nozzle orifice
Pump surges:	Low flow may cause pump to surge
	Spray Wand is adjusted to small or fine of a spray pattern
	Check for defective pressure switch
	Check for leaks in the discharge line
	Check for debris in nozzle orifice
	Discharge hose may be too long
Pump continues to run:	Check for clogged strainer/filter
	Pressure switch may need to be adjusted 1/4 turn at a time clockwise until surging stops
	Check for empty product supply
Fuse blows:	Check for Low Voltage
	Check for leaks in the discharge line
	Check for defective pressure switch
	System has leaks
	Air trapped in outlet line or pump head
	Excessive voltage
	Improper adjustment of pressure switch
	Damaged or defective wiring harness
	Defective pressure switch
	Half-moon & Counterweight are sticking

**Motor is NOT Running - Checking the Pressure Switch:**

If motor is not running and you've checked the following: for loose wiring connections, fuse, switch on lead wire was "ON" and made sure you were connected to a fully charged battery but the motor won't run, then it's time to check to see if the pressure switch is bad.

- Remove the cover off the 1" square box (pressure switch) on the head of the pump, the cover is held on by one phillips-head screw. This will expose the two red wires.
- With the pump connected to a good 12 volt power source and everything on.
- Slip the two red wires off the terminals and touch them together.

- ◆ If motor runs, it means the pressure switch is bad and needs to be replaced.
- ◆ If motor still doesn't run, try bypassing the switch in the lead wire or using another lead wire. Even if a tester shows power to the pressure switch, still try this test.

**Warning:** It is NOT recommended to run the pump this way, as the pump will continue to run and not shut off. This could result in blown hoses when all discharges are closed or premature failure of the pump completely.

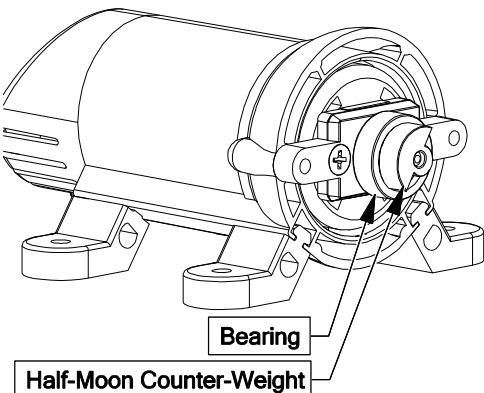
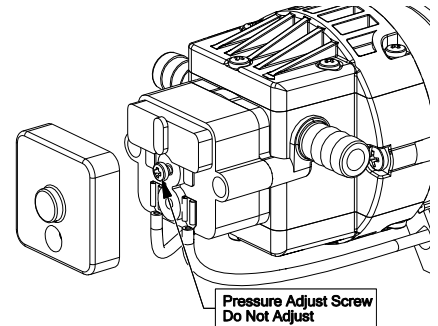

**Motor Running-BUT No Pressure:**

CHECK:

Both the counterweight and the bearing need to spin freely and both need to spin INDEPENDENTLY of each other. If these 2 pieces are 'stuck' together, you will need to break them free and whether or not they are sticking, spray some good quality lubricant or something similar on them and let it soak in and this should restore most of your prime.

# Exploded View/Parts List:

## LG-8-P (5302164)

Underside View, looking inside the lower tray, showing pump/battery orientation.

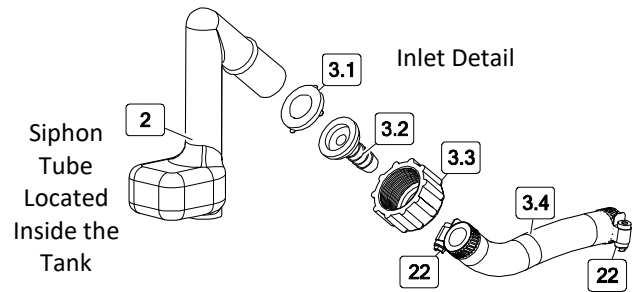
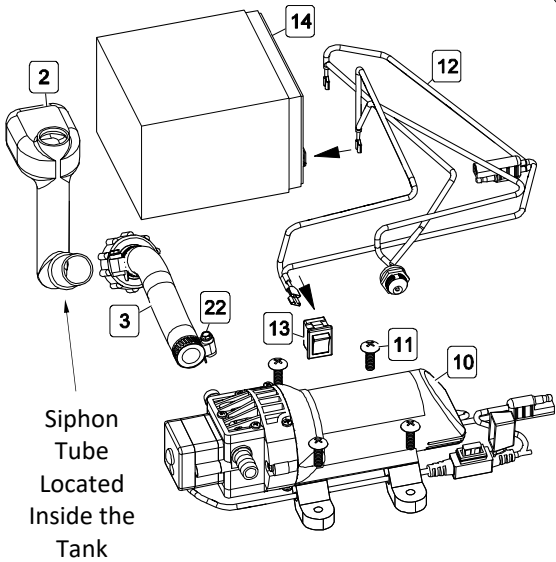
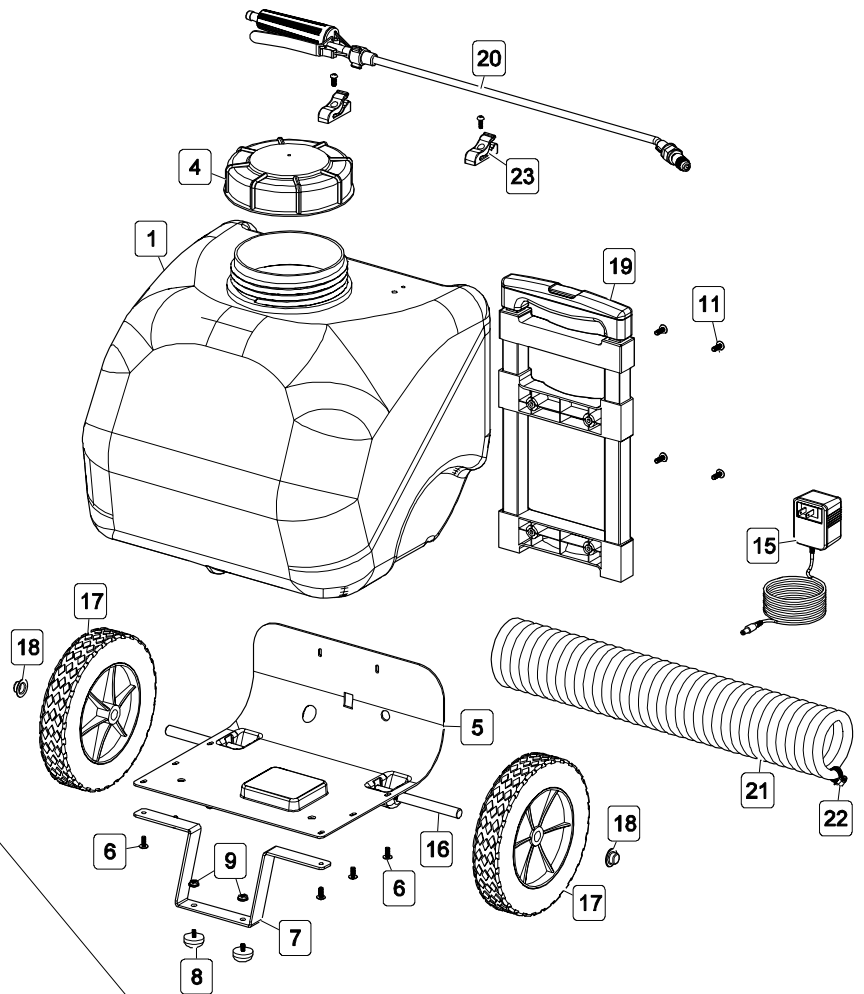
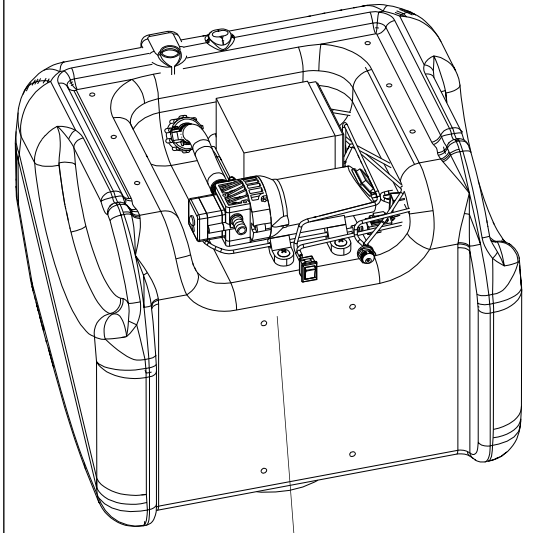

Ref. #	Part #	Description	Qty
1	5169279	8 Gallon Tank	1
2	5100710	Siphon Tube (LG-8)	1
3	5277447	Intake Sub-Assembly (LG-8)	1
3.1	5116242	Strainer, 1" Filter Washer	1
3.2	5149034	Poly Swivel, 3/8" Hose Barb	1
3.3	5006209	Poly Knurled Swivel Nut, 3/4" FGHT	1
3.4	5020505	Hose, 3/8"-1 Brd. x 5 1/4"	1
4	5058189	5" Lid (NO Lanyard)	1
5	5027425	Cover Plate (LG-8)	1
6	5117234	#10-24 x 1/2" PH Truss Head Screw	6
7	5038746	Front Foot Bracket	1
8	5040004	Rubber-Headed Screw Bumper (#10-24)	2
9	5006186	#10-24 Hex Flange Whiz Nut	2
10	5281370	12V Pump, 1.2 GPM Pump, 60 PSI	1

Ref. #	Part #	Description	Qty
11	5117167	#10-24 x 5/8" PH Truss Head Screw	8
12	5157217	Wiring Harness, 2.1mm Jack(LG-5-P)	1
13	5157212	ON/OFF Rocker Switch (w/o Cover)	1
14	5157209	Battery (12 Volt, 5 Amp)	1
15	5157216	Battery Charger 2.1mm Barrel Style Jack	1
16	5024106	Axle (LG-8-P)	1
17	5021044	Wheel, 8" x 1.75" x 1/2"	2
18	5046023	1/2" Cap Push Nut, Zinc Plated	2
19	5078221	Locking Handle (LG-8)	1
20	5163100	Low-Flow Spray Wand w/X-26 Tip	1
21	5020479	15 Ft. Coiled Hose (3/8" I.D.)	1
22	5051144	Hose Clamp, 3/8"	4
23	5274880	Handgun Clips & Screws (Pkg/2)	1

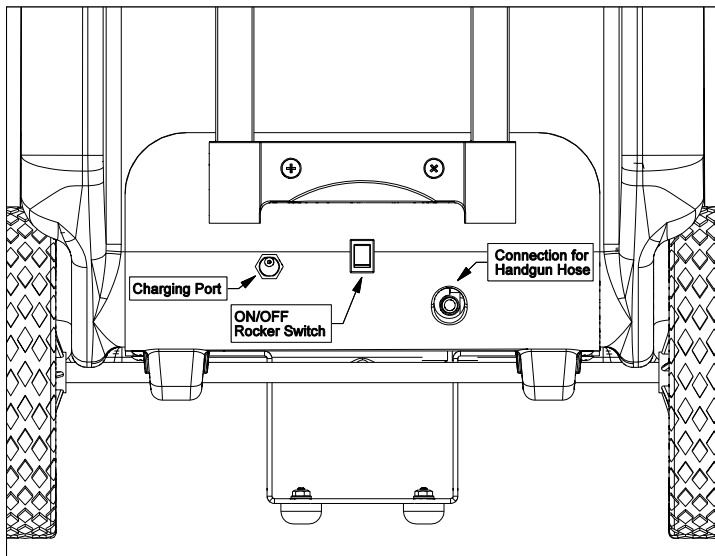

Cut View of Inside Tank to show Siphon Tube

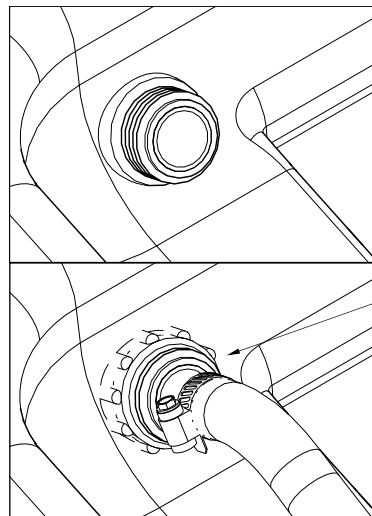
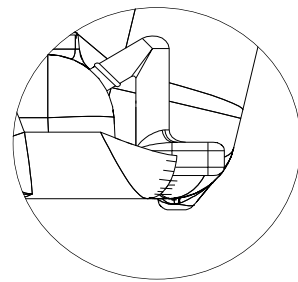

Molded-In' Inlet Fitting & Intake Sub-Assembly Attachment

Filter/Screen Location

Approx. Dimensions

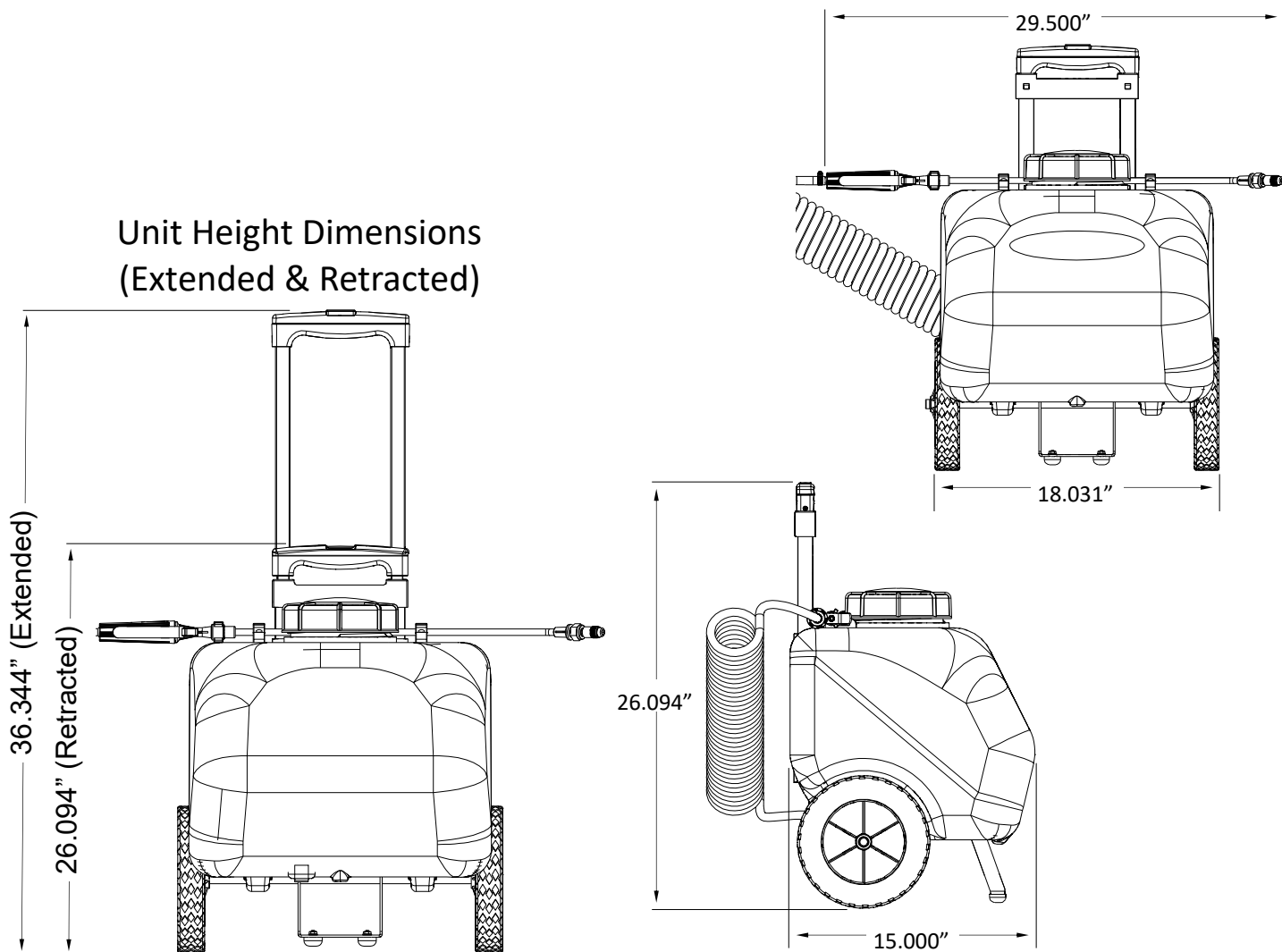

# Warranty

## LIMITED WARRANTY FOR NEW FIMCO, IND. EQUIPMENT

**WHO MAY USE THIS LIMITED WARRANTY.** This limited warranty (the "Limited Warranty") is provided by Fimco, Ind. to the original purchaser ("you") of the Equipment (as defined below) from Fimco, Ind. or one of Fimco, Ind.'s authorized dealers. This Limited Warranty does not apply to any subsequent owner or other transferee of the Equipment. THIS LIMITED WARRANTY GIVES YOU SPECIFIC LEGAL RIGHTS, AND YOU MAY ALSO HAVE OTHER RIGHTS WHICH VARY FROM STATE TO STATE.

**WHAT THIS LIMITED WARRANTY COVERS AND FOR HOW LONG.** Fimco, Ind. warrants that any new Equipment will be free from defects in material and workmanship for a period of **one (1) year** for sprayer and **two (2) years** for High-Flo High Performance pump (homeowner), **90 days** for sprayer and pump (commercial user), after delivery of the Equipment to you (the "Warranty Period"). The Warranty Period is not extended if Fimco, Ind. repairs or replaces the Equipment.

**WHAT IS NOT COVERED BY THIS LIMITED WARRANTY.** This Limited Warranty does not apply to: (1) used Equipment; (2) any Equipment that has been altered, changed, repaired or treated since its delivery to you, other than by Fimco, Ind. or its authorized dealers; (3) damage or depreciation due to normal wear and tear; (4) defects or damage due to failure to follow Fimco, Ind.'s operator's manual, specifications or other written instructions, or improper storage, operation, maintenance, application or installation of parts; (5) defects or damage due to misuse, accident or neglect, "acts of God" or other events beyond Fimco, Ind.'s reasonable control; (6) accessories, attachments, tools or parts that were not manufactured by Fimco, Ind., whether or not sold or operated with the Equipment; or (7) rubber parts, such as tires, hoses and grommets.

**HOW TO OBTAIN WARRANTY SERVICE.** To obtain warranty service under this Limited Warranty, you must (1) provide written notice to Fimco of the defect during the Warranty Period and within **thirty (30)** days after the defect becomes apparent or the repair becomes necessary, at the following address: Fimco, 1000 Fimco Lane, North Sioux City, SD 57049; and (2) make the Equipment available to Fimco or an authorized dealer within a reasonable period of time. For more information about this Limited Warranty, please call: **800-831-0027**

**WHAT REMEDIES ARE AVAILABLE UNDER THIS LIMITED WARRANTY.** If the conditions set forth above are fulfilled and the Equipment or any part thereof is found to be defective, Fimco, Ind. shall, at its own cost, and at its option, either repair or replace the defective Equipment or part. Fimco, Ind. will pay for shipping and handling fees to return the repaired or replacement Equipment or part to you.

**LIMITATION OF IMPLIED WARRANTIES AND OTHER REMEDIES.** THE REMEDIES DESCRIBED ABOVE ARE YOUR SOLE AND EXCLUSIVE REMEDIES, AND FIMCO, IND.'S SOLE LIABILITY, FOR ANY BREACH OF THIS LIMITED WARRANTY. TO THE EXTENT APPLICABLE, ANY IMPLIED WARRANTIES, INCLUDING, WITHOUT LIMITATION, THE IMPLIED WARRANTIES OF MERCHANTABILITY AND FITNESS FOR A PARTICULAR PURPOSE, SHALL BE LIMITED IN DURATION TO THE WARRANTY PERIOD, AND THE REMEDIES AVAILABLE FOR BREACH THEREOF SHALL BE LIMITED TO THE REMEDIES AVAILABLE UNDER THIS EXPRESS LIMITED WARRANTY. SOME STATES DO NOT ALLOW LIMITATIONS ON HOW LONG AN IMPLIED WARRANTY LASTS, SO THE ABOVE LIMITATION MAY NOT APPLY TO YOU. IN NO EVENT SHALL FIMCO, IND.'S LIABILITY UNDER THIS LIMITED WARRANTY EXCEED THE ACTUAL AMOUNT PAID BY YOU FOR THE DEFECTIVE EQUIPMENT, NOR SHALL FIMCO, IND. BE LIABLE, UNDER ANY CIRCUMSTANCES, FOR ANY CONSEQUENTIAL, INCIDENTAL, SPECIAL OR PUNITIVE DAMAGES OR LOSSES, WHETHER DIRECT OR INDIRECT. SOME STATES DO NOT ALLOW THE EXCLUSION OR LIMITATION OF INCIDENTAL OR CONSEQUENTIAL DAMAGES, SO THE ABOVE LIMITATION OR EXCLUSION MAY NOT APPLY TO YOU.