

OWNER'S MANUAL

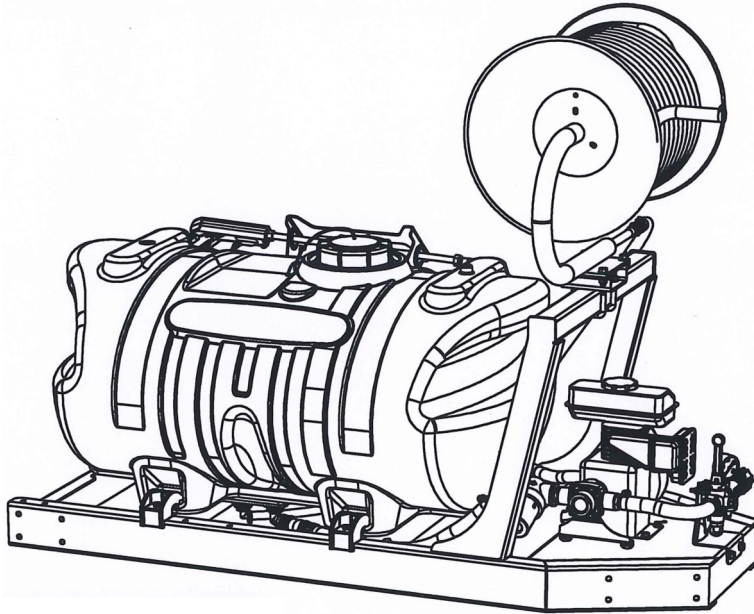

Model: SK-61-4R-HR (5301379)

(60 Gallon Skid Sprayer w/127cc B&S Engine,
4-Roller Pump, Deluxe Handgun
& Hose Reel Assembly)

Caution: When fully filled with water, this sprayer will weigh approx. 760 lbs.. Consult the owner's manual for your vehicle to verify that you are within it's load carrying capacity.

BEFORE RETURNING THIS PRODUCT
FOR ANY REASON, PLEASE CALL

1-800-831-0027

IF YOU SHOULD HAVE A QUESTION OR
EXPERIENCE A PROBLEM WITH YOUR
FIMCO INDUSTRIES PRODUCT:

1-800-831-0027

BEFORE YOU CALL, PLEASE HAVE THE
FOLLOWING INFORMATION AVAILABLE:
SALES RECEIPT & MODEL NUMBER. IN MOST
CASES, A FIMCO INDUSTRIES EMPLOYEE CAN
RESOLVE THE PROBLEM OVER THE PHONE.

General Information

Thank you for purchasing this product. The purpose of this manual is to assist you in operating and maintaining your skid sprayer.



WARNING: To reduce the risk of injury, the user must read and understand the operator's manual before using this product.



WARNING: Cancer and Reproductive Harm
www.P65Warnings.ca.gov

**Retain a copy of your receipt for your unit,
as it will be required to validate any warranty service**
**Products are warranted against manufacturer or workmanship
defects for one year from date of purchase for home owner
usage and 90 days for commercial usage.**

For technical assistance, visit our website @
www.fimcoindustries.com or call: **TOLL FREE @ 1-800-831-0027**
Our Technical Support Representatives will be happy to help you.
To obtain prompt, efficient service, always remember to give the
following information...

- Correct Part Description and/or part number
- Model #/Serial # of your sprayer

Part descriptions and numbers can be obtained from the illustrated parts list section(s) of this manual.

Technical Specifications

- 127cc B&S Engine
- 4 Roller Pump - 6 G.P.M.
- Pressure Relief Valve
- Deluxe Pistol Grip Handgun W/25' of Hose
- Hose Reel w/100' of 1/2" Hose
- Optional Trailers & Boom Features Available

Assembly Instructions

The sprayer is mostly assembled, except for the pressure gauge and the hose reel assembly.

Assemble the hose reel assembly to the skid as shown later in this manual. Using a good grade of thread sealant, thread the gauge into the valve assembly at the front of the skid unit.

The only other time any assembly is required is if you have purchased the optional trailer assembly or optional boom assembly.

NOTE:

Add proper oil to the engine crankcase and gasoline to the gas tank. Refer to the engine manual for the correct type and amount.

It is important to test the sprayer with plain water before actual spraying is attempted. This will enable you to check the sprayer for leaks in the plumbing system.



www.fimcoindustries.com

1000 FIMCO Lane, P.O. Box 1700, North Sioux City, SD 57049
Toll Free Phone: 800-831-0027 : Toll Free Fax: 800-494-0440

[5004600

(01/19)]

IMPORTANT:

Remove tank lid and be sure the tank is clean and free of any foreign material. Rinse tank out of any tank residue before filling with water to test.

Testing the Sprayer

1. Fill the tank about 1/2 full with plain water.
2. Open the brass valve in the suction line (See Detail A) and allow water to flow to the pump. The valve is located at this point to enable the strainer to be taken apart for cleaning, while solution remains in the tank.

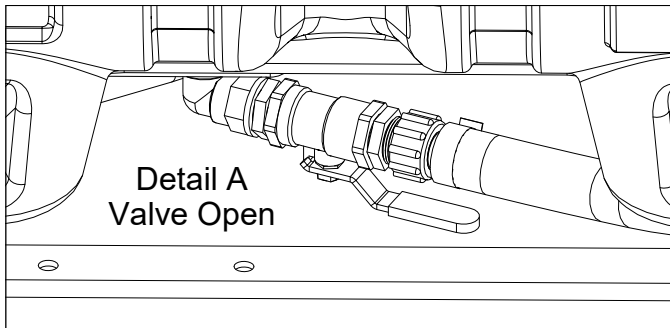

CAUTION:

Always be sure that the water (or solution) has reached the roller pump before starting your sprayer. If the pump is allowed to run dry, serious damage to the pump will result. Do not run your sprayer with the boom/handgun line closed AND the bypass line closed. Doing this will damage the pump.

3. It is always best to start the sprayer at little or no pressure. This sprayer is equipped with a spring loaded pressure relief/bypass valve. Turn the valve knob out to decrease pressure and in for increased pressure.

The bypass valve is the "pressure control" for the entire plumbing system. The more the valve is open, the lower your line pressure. Almost fully closed provides maximum pressure to your boom and/or handgun. **NEVER run your system with this valve 100% closed.**

4. You may now start the sprayer engine following the engine manufacturers instructions. Let the sprayer run at low pressure until water has reached the handgun and all air has been purged from the system.

Caution:

Care must be taken, being sure the handgun is secured in the operators hand. If this is not done a recoiling action may occur causing damage or personal injury.

Conditions of weather and terrain must be considered when setting the sprayer. Do not spray on windy days. Protective clothing must be worn in some cases

Be sure to read the chemical label(s) before application!

Information About the Sprayer

In this pumping system, solution is drawn from the tank and forced to a planned source, such as boom nozzles or handgun. The pressure is controlled by opening/closing the valve which recirculates solution back into the tank.

Priming the pump

To help prime the pump, keep the inlet or suction line as short as possible with a minimum of bends, elbows and kinks. Make sure all connections are tight and do not leak air. Make sure the line strainer is free of debris. If pump does not self-prime, disconnect suction hose, fill with water and reconnect to liquid source. Often a squirt of oil into the ports of the pump will seal clearances and help priming. Facing the pump, the suction port is on your left.

Maintenance During/After Spraying

Periodically close the suction line valve and check the line strainer and clean the screen.

Proper care and maintenance will keep your pump wear at a minimum and will keep it running smoothly and trouble-free for a long time and prolong the life of your sprayer.

After use, fill the sprayer tank part way with water. Start the sprayer and allow the water to pump through the entire plumbing system and nozzles. Drain and then refill half full with plain water, add the recommended amount of good quality tank cleaner such as FIMCO Sprayer Tank Neutralizer and Cleaner. (If no tank cleaner is available, you may substitute dish soap for this step.) Turn sprayer on and circulate through system for 15 minutes and then spray out through handgun nozzle (and boom nozzles if applicable). Refill tank half way with clean water and repeat. Follow the chemical manufacturer's disposal instructions of all wash or rinsing water.

For the boom (if applicable) remove the tips and screens from the nozzle assemblies. Wash these items out thoroughly. Blow the orifice clean and dry. If the orifice remains clogged, clean it with a fine bristle (NOT WIRE) brush or with a toothpick. Do not damage the orifice. Water rinse and dry the tips before storing.

Flush the pump after each use. One of the common causes of faulty pump performance is "gumming" or corrosion inside the pump. This prevents the rollers from moving freely. Flush the pump with a solution that will neutralize liquid pumped. A rust inhibitor can also be squirted into the ports of the pump. Turn shaft several times to draw protective liquid through pump and coat entire inner surface.

WARNING: Never pump corrosive or abrasive liquids as these will cause rapid wear or deterioration of body, rotor, shaft and seals in the pump. Never run pump dry. Some chemicals will damage the pump valves if allowed to soak untreated for a length of time! ALWAYS flush the pump as instructed after each use. DO NOT allow chemicals to sit in the pump for extended times of idleness. Failure to follow this warning will void the product warranty.

Follow the chemical manufacturer's instructions on disposal of all waste water from the sprayer.

Winter Storage

Prepare the sprayer for end-of-season storage by draining all water out of your sprayer, paying special attention to the pump, handgun and valve(s). These items are especially prone to damage from chemicals and freezing weather.

The sprayer should be winterized before storage by pumping a solution of automotive antifreeze (containing a rust inhibitor) through the entire plumbing system. This antifreeze solution should remain in the plumbing system during the winter months. When spring time comes and you are preparing your sprayer for the spray season, rinse the entire plumbing system out, clearing the lines of the antifreeze solution.

Proper care and maintenance will prolong the life of your sprayer.

It is nearly impossible to drain all of the water from the sprayer and any trapped water can freeze in cold weather and damage parts of the sprayer. Pumping the antifreeze through the system will displace the water and help prevent this damage.

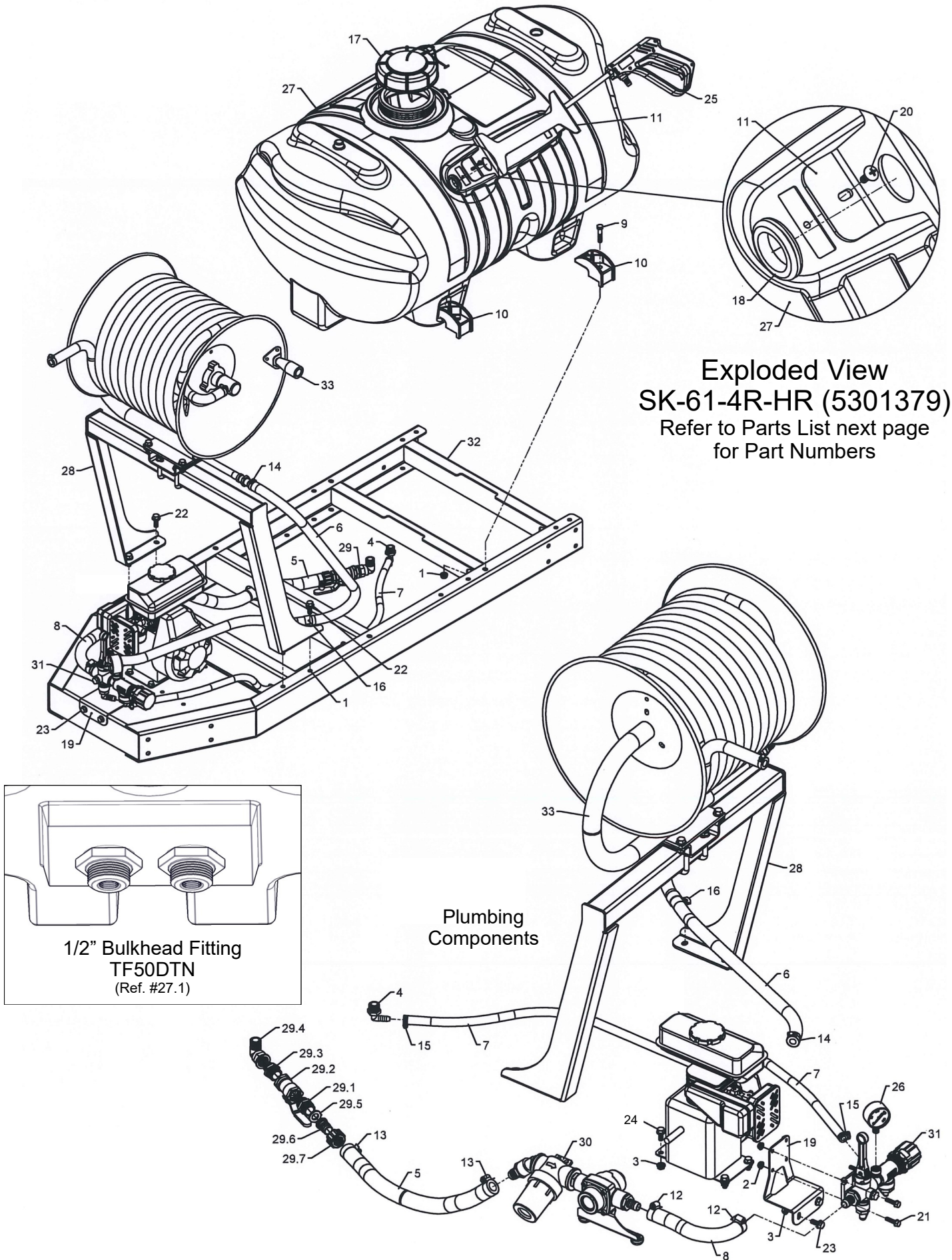

Exploded View
SK-61-4R-HR (5301379)
 Refer to Parts List next page
 for Part Numbers

1/2" Bulkhead Fitting
 TF50DTN
 (Ref. #27.1)

Plumbing
 Components

Parts List: SK-61-4R-HR (5301379)

Ref. #	Part #	Description	Qty.
1	5006259	3/8"-16nc Hex Flanged Whiz Nut, Grade 5	8
2	5006306	1/4"-20nc Hex Flanged Whiz Nut, Grade 5	4
3	5006307	5/16"-18nc Hex Flanged Whiz Nut, Grade 5	6
4	5010202	Poly Elbow, 1/2" MPT x 3/8" HB	1
5	5020378	Hose, 3/4"-2 Brd. x 21"	1
6	5020462	Hose, 1/2"-1 Brd. x 31"	1
7	5020530	Hose, 3/8"-1 Brd. x 51"	1
8	5020546	Hose, 5/8"-1 Brd. x 14"	1
9	5034101	3/8"-16 x 1-3/4" Hex Bolt	4
10	5038698	Plastic Tank Hold-Down Leg Clip	4
11	5038775	Handgun Bracket	1
12	5051023	Hose Clamp, 5/8"	2
13	5051024	Hose Clamp, 3/4"	2
14	5051114	Hose Clamp, 1/2"	2
15	5051144	Hose Clamp, 3/8"	2
16	5053027	Hose Clamp	1
17	5058188	Tank Lid w/Lanyard	1
18	5075014	Rubber Grommet (Black)	2
19	5095366	Manifold Mount	1
20	5117234	#10-24 x 1/2" Phillips Truss Head Mach. Screw	2
21	5117325	1/4-20 x 3/4" Pan Head Mach. Screw	4

Ref. #	Part #	Description	Qty.
22	5117307	H.H.C.S. Flanged 3/8"-16nc x 1"	4
23	5117323	5/16"-18nc x 3/4" Flng Hex Bolt	2
24	5034638	5/16"-18 x 1-1/2" Flng Hex Bolt	4
25	5163112	Deluxe Pistol Grip Handgun w/X-26 Tip (1/2" Hos	1
26	5167004	Pressure Gauge, 0-200 PSI (Dry)	1
27	5169249	60 Gallon Elliptical Tank (White)	1
27.1	TF50DTN	1/2" Heavy Duty Double Threaded Bulkhead Fittir	2
28	5274901	Hose Reel Mount Weldment	1
29	5274939	Tank Valve Assembly	1
29.1	5005196	Poly Adapter, 3/4" MNPT x 3/4" MGHT	1
29.2	5143190	3/4" "T-800" Brass Ball Valve	1
29.3	5011147	Poly Reducing Nipple, 3/4" MPT x 1/2" MPT	1
29.4	5010243	90° Poly Street Elbow, 1/2" MPT x 1/2" FPT	1
29.5	5016066	Garden Hose Washer	1
29.6	5149037	Poly Swivel, 3/4" Flat Seat Hose Barb	1
29.7	5006209	Poly Knurled Nut, 3/4" FGHT	1
30	5278061	Engine/Pump Assembly	1
31	5278071	Valve Assembly	1
32	5278082	60 Gallon Skid Weldment (Red)	1
33	5301342	SK-61 Hose Reel/Hose Assembly	1

Engine/Pump Assembly (5278061)

Ref. #	Part #	Description	Qty.
30	5278061	Pump/Engine Assembly	1
30.1	5277100	Engine/Pump Sub-Assembly	1
30.1.1	5152107	B&S 5.5 Gross Torque Engine (5/8" Shaft)	1
30.1.2	5273020	4-Roller Cast Iron Pump & Coupler	1
30.1.2.1	5271757	4-Roller Cast Iron Pump (4101C)	1
30.1.2.2	5005175	Adapter & Kit (Coupler)	1
30.1.3	5274705	Shield Assembly	1
30.1.4	5034108	H.H.C.S., 5/16"-24 x 5/8"	2
30.1.5	5016026	Lockwasher, 5/16"	2
30.2	5067126	Poly Fitting, 3/4" MPT x 5/8" HB	1
30.3	5011140	Poly Close Nipple, 3/4" MPT	1
30.4	5116322	3/4" Black Poly Strainer	1
30.4.1	5072229	EPDM Gasket	1
30.4.2	5116323	40 Mesh Screen	1
30.5	5010249	45° Poly Street Elbow, 3/4" NPT	1
30.6	5067127	Poly Fitting, 3/4" MPT x 3/4" HB	1

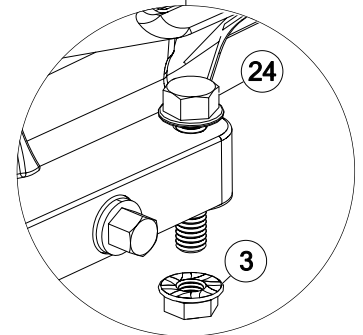
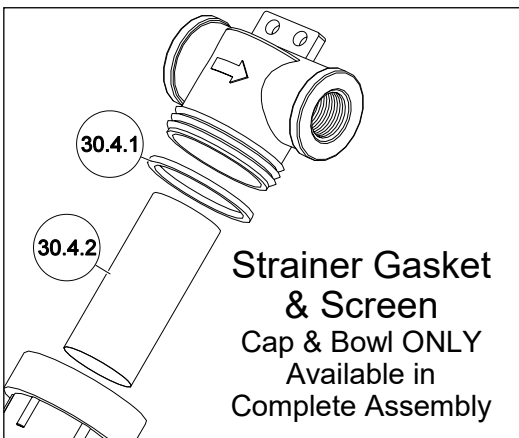
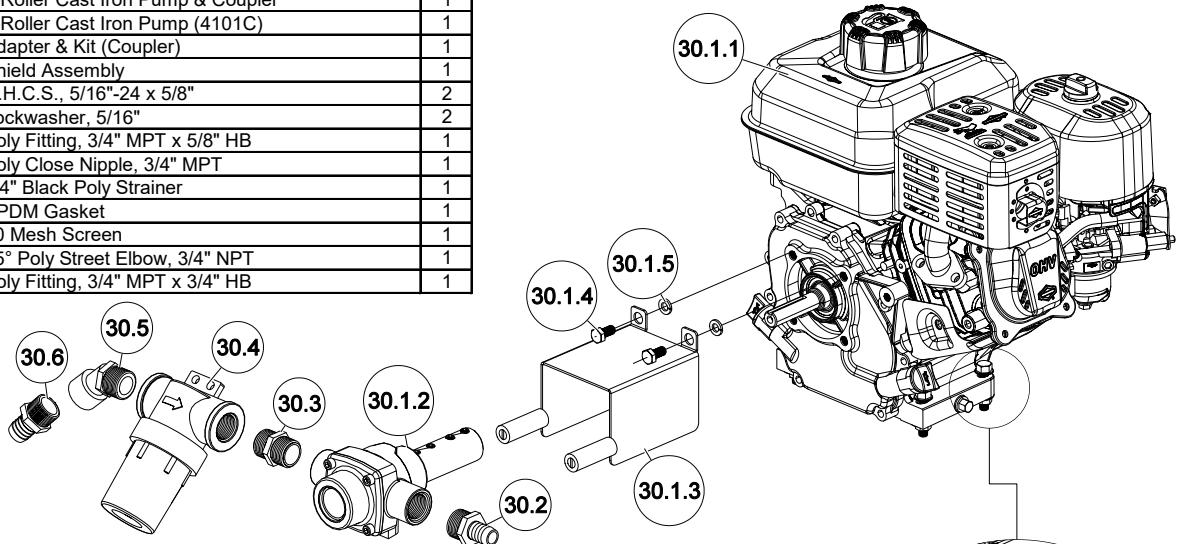

Items #3 & #24 are not part of the engine/pump assembly
See above for part numbers

Valve Assembly (5278071)

Ref. #	Part #	Description	Qty.
31	5278071	Valve Assembly	1
31.1	5010203	Poly Elbow, 1/2" MPT x 1/2" HB	1
31.2	5010206	Poly Elbow, 3/4" MPT x 3/8" HB	1
31.3	5067126	Poly Fitting, 3/4" MPT x 5/8" HB	1
31.4	5143199	Pressure Relief Valve (3/4" NPT)	1
31.5	5143316	Directo-Valve (AA6B)	1

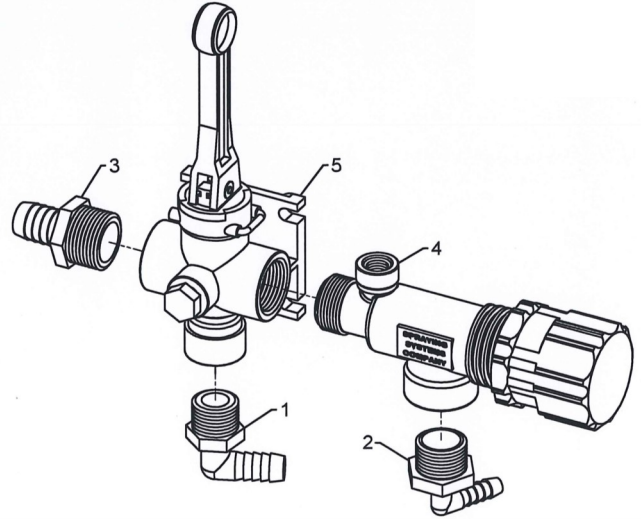

Tank Valve Assembly (5274939)

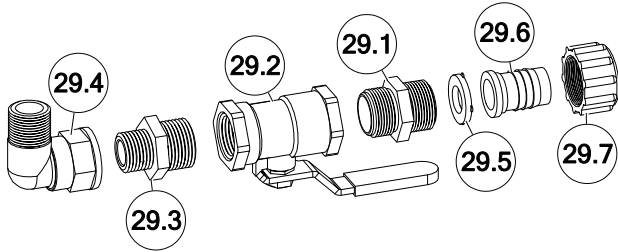

Ref. #	Part #	Description	Qty.
29	5274939	Tank Valve Assembly	1
29.1	5005196	Poly Adapter, 3/4" MNPT x 3/4" MGHT	1
29.2	5143190	3/4" "T-800" Brass Ball Valve	1
29.3	5011147	Poly Reducing Nipple, 3/4" MPT x 1/2" MPT	1
29.4	5010243	90° Poly Street Elbow, 1/2" MPT x 1/2" FPT	1
29.5	5016066	Garden Hose Washer	1
29.6	5149037	Poly Swivel, 3/4" Flat Seat Hose Barb	1
29.7	5006209	Poly Knurled Nut, 3/4" FGHT	1

STOP WARNING STOP
DO NOT USE PUMP IN AN EXPLOSIVE ENVIRONMENT. DO NOT USE TO PUMP FLAMMABLE/COMBUSTIBLE FLUIDS, GASOLINE, KEROSENE, FUEL, OIL, ETC.

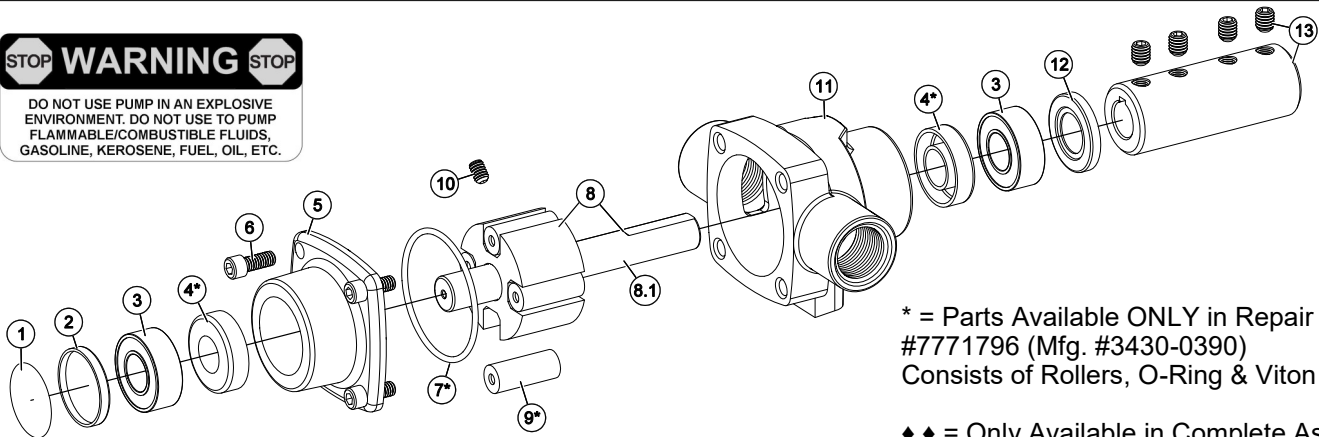

* = Parts Available ONLY in Repair Kit #7771796 (Mfg. #3430-0390) Consists of Rollers, O-Ring & Viton Seals

◆◆ = Only Available in Complete Assembly

Cast Iron 4-Roller Pump Assembly #5273020 (Hypro Mfg. Part #: 4101C-01)

For electric motor drive:
Output to 9 GPM, Pressure to 150 psi,
Speed to 1800 RPM, Temperature to 140°F.

For gas engine drive:
Output to 7 GPM, Pressure to 150 psi,
Speed to 2600 RPM, Temperature to 140°F

Ref. #	Part #	Mfg. Part #	Description	Qty
1	---	---	Pump Model Sticker/Label	1
2	5017481	2300-0021	Bearing Cover	1
3	5031113	2000-0010	Ball Bearing (Sealed)	2
4*	5110052	2107-0002	Seal (Viton)	2
5	◆◆	0200-4101C	Endplate (Cast Iron) w/Seal	1
6	◆◆	2220-0018	1/4"-20 x 5/8" Socket Head Cap Screw	4
7*	5072220	1720-0104	O-Ring Gasket for Endplate	1
8	5172127	0300-4101C	Rotor & Shaft Assembly	1
8.1	0500-6600	0500-6600	Shaft (Only)	1
9*	5112029	1005-0002	Super Roller (Standard)	4
10	◆◆	2230-0002	1/4"-20 x 3/8" Set Screw	1
11	◆◆	0100-4101C	Body (Cast Iron) w/Seal	1
12	5017480	2300-0023	Shaft Bearing Cover	1
13	5005175	1320-0016	Adapter & Kit (Coupler)	1

Roller Pump General Safety Information

1. Use a pressure relief device on the discharge side of the pump to prevent damage from pressure buildup when the pump discharge is blocked or otherwise closed and the power source is still running.
2. **WARNING:** Never pump flammable or explosive fluids such as gasoline, fuel oil, kerosene, etc. Never use in explosive atmospheres. The pump should be used only with liquids compatible with the pump component materials. Failure to follow this warning can result in personal injury and/or property damage and will void the product warranty.
3. Never pump acids (i.e. acid fertilizer) with Super Rollers!
4. Never run the pump faster than maximum recommended speed.
5. Never pump at pressures higher than the maximum recommended pressure.
6. Never pump liquids at temperatures higher than the recommended maximum temperatures (140°F/60°C).
7. Make certain that the power source conforms to the requirements of your equipment.
8. Provide adequate protection in guarding around the moving parts such as the shaft and pulleys.
9. Disconnect power before servicing.
10. Release all pressure within the system before servicing any component.
11. Drain all liquids from the system before servicing any component.
12. Check all hoses for weak or worn condition before each use. Make certain that all connections are tight and secure.
13. Periodically inspect the pump and the system components. Perform routine maintenance as required.
14. Never operate a gasoline engine in an enclosed area. Be sure the area is well ventilated.
15. Use only pipe, hose and fittings rated for the maximum psi rating of the pump.
16. Never use pump for pumping water or other liquids for human or animal consumption.

Roller Pump Operation & Maintenance

WARNING: Never pump corrosive or abrasive liquids as these will cause rapid wear or deterioration of the body, rotor, shaft and seals in the pump. The pump should be used on with liquids compatible with pump component materials. Never exceed maximum specified rpm and pressure. Never run pump dry. Failure to follow this warning will void the product warranty.

Priming the Pump:

To help prime the pump, keep the inlet or suction line as short as possible with a minimum of bends, elbows and kinks. Make sure all connections are tight and do not leak air. Make sure line strainer is free of debris. If pump does not self-prime, disconnect suction hose, fill with water and reconnect to liquid source. Often a squirt of oil into the ports of the pump will seal clearance and help priming.

Care of the Pump:

Proper care and maintenance will keep your pump wear at a minimum and will keep it running smoothly and trouble-free for a long time.

Flush the Pump After Each Use

One of the common causes of faulty pump performance is “gumming” or corrosion inside the pump. This prevents rollers from moving freely in their rotor slots. Flush the pump with a solution that will neutralize liquid pumped, mixed according to manufacturer’s directions.

To Prevent Corrosion:

After cleaning pump as above, flush it with a 50-50 solution of permanent-type automotive antifreeze (containing a rust inhibitor) and water. A rust inhibitor can also be squirted into the ports of the pump. Turn shaft several times to draw protective liquid through pump and coat entire inner surface. Drain pump and plug ports to keep out air during storage. For short periods of idleness, noncorrosive liquids may be left in the pump, but air must be kept out. Plug ports or seal port connections.

Troubleshooting		
Symptom	Probable Cause(s)	Corrective Action
Pump Does Not Prime	Leak in suction line	Check hose and fittings for leaks and correct
	Obstruction in suction line	Inspect hose for debris or loose inner liner in hose
	Suction hose sucked to bottom or side of tank	Cut a notch or "V" in end of suction hose
	Rollers stuck in pump	Disassemble pump and inspect rollers
	Pump seals leaking air	Replace seals
Loss of Pressure	Clogged suction strainer	Check strainer and clean it regularly
	Kinked or blocked suction hose	Inspect suction hose and repair as necessary
	Air leak in inlet side plumbing	Check hose and connections for leaks Use pipe joint sealant and retighten connections
	Relief valve setting too low or weakened spring	Check relief valve and correct setting
	Faulty Gauge	Replace gauge
	Pump seals leak air	Replace seals
	Nozzle orifices worn	Replace nozzles
Pump worn	Repair pump	
Pump will not turn	Corrosion (rust), scale or residue	Loosen endplate bolts. Squirt oil into ports to help free rotor. Retighten bolts.
	Solid object lodged in pump.	Disassemble pump and remove objects

'Directo Valve' - Manually Operated Control Valve

- Corrosion Resistant Materials: Wetted Parts Polypropylene, 316SS and Polyethylene
- Maximum Pressure = 150 p.s.i.
- Large Capacity - 12.5 G.P.M. @ 5 p.s.i. Pressure Drop
- 3/4" NPT (F) Inlet Connection
- 1/2" NPT (F) Spray Line Connection
- 3/4" NPT (F) Continuous By-Pass Connection
- Valves may be connected w/close nipples for multiple section spray control

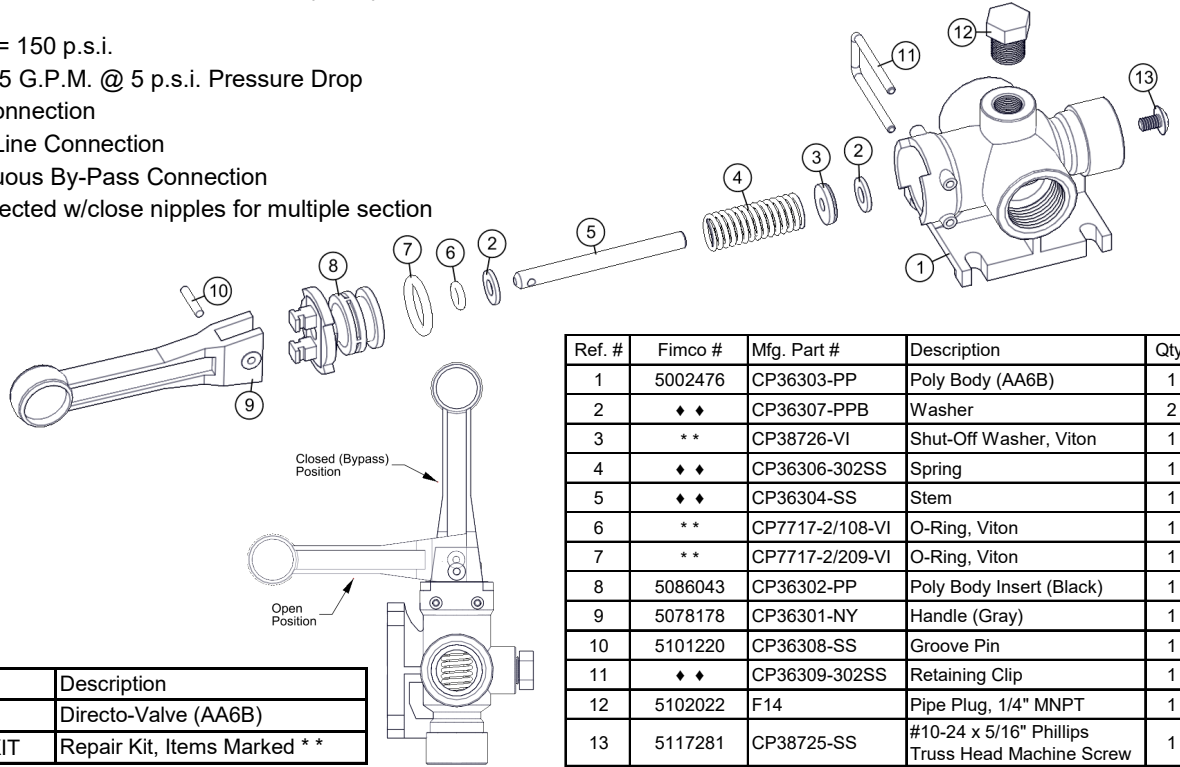

Fimco #	Mfg. Part #	Description
5143316	AA6B	Directo-Valve (AA6B)
5168718	PK-AB6B-KIT	Repair Kit, Items Marked **

Ref. #	Fimco #	Mfg. Part #	Description	Qty.
1	5002476	CP36303-PP	Poly Body (AA6B)	1
2	◆◆	CP36307-PPB	Washer	2
3	**	CP38726-VI	Shut-Off Washer, Viton	1
4	◆◆	CP36306-302SS	Spring	1
5	◆◆	CP36304-SS	Stem	1
6	**	CP7717-2/108-VI	O-Ring, Viton	1
7	**	CP7717-2/209-VI	O-Ring, Viton	1
8	5086043	CP36302-PP	Poly Body Insert (Black)	1
9	5078178	CP36301-NY	Handle (Gray)	1
10	5101220	CP36308-SS	Groove Pin	1
11	◆◆	CP36309-302SS	Retaining Clip	1
12	5102022	F14	Pipe Plug, 1/4" MNPT	1
13	5117281	CP38725-SS	#10-24 x 5/16" Phillips Truss Head Machine Screw	1

** Available only in Repair Kit

◆◆: Only Available in Complete Assembly

Piston Type Pressure Relief/Regulating Valves

Bypasses excess fluid. Adjustable to maintain control of line pressure at any pressure within the valve operating range. Selected pressure setting firmly held in place by locknut. Extra large passages to handle large flows.

- Polypropylene with stainless steel spring
- Excellent chemical resistance
- EPDM O-Rings
- Fore pressure to 150 p.s.i.
- 1/4" port for pressure gauge
- Choice of 1/2" or 3/4" NPT (M) inlet & (F) outlet connections

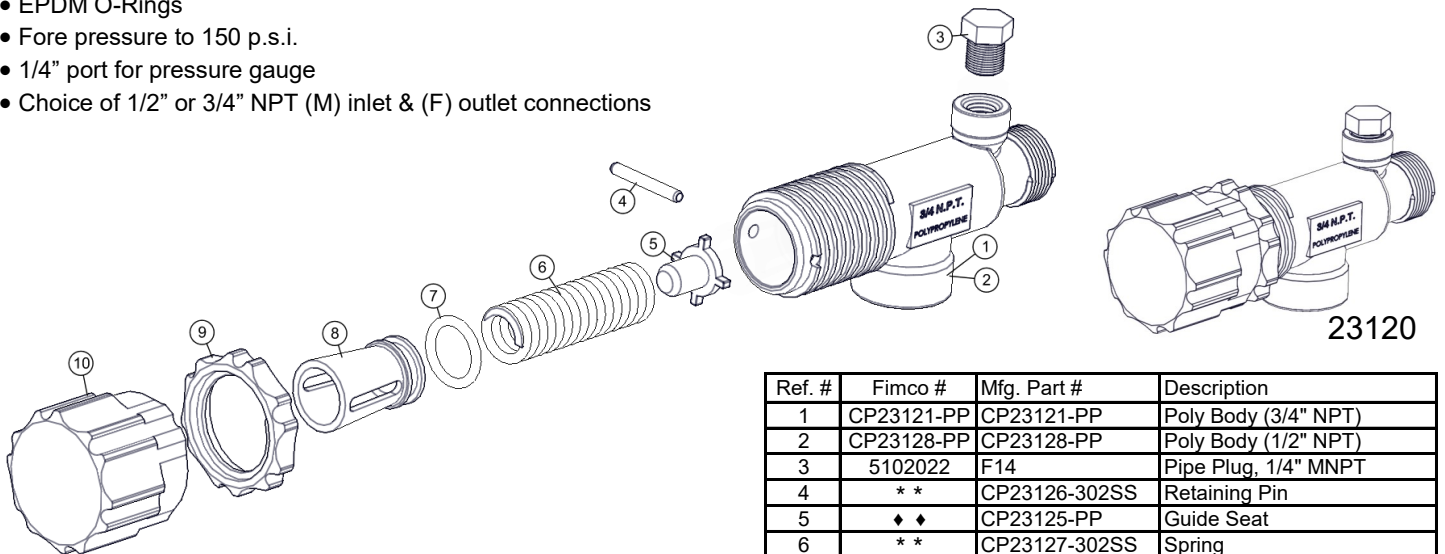

Fimco #	Mfg. Part #	Description
5143199	23120-3/4-PP	Pressure Relief Valve (3/4" NPT)
5143200	23120-1/2-PP	Pressure Relief Valve (1/2" NPT)
5168717	PK-AB23120-KIT	Repair Kit, Items Marked **

Ref. #	Fimco #	Mfg. Part #	Description
1	CP23121-PP	CP23121-PP	Poly Body (3/4" NPT)
2	CP23128-PP	CP23128-PP	Poly Body (1/2" NPT)
3	5102022	F14	Pipe Plug, 1/4" MNPT
4	**	CP23126-302SS	Retaining Pin
5	◆◆	CP23125-PP	Guide Seat
6	**	CP23127-302SS	Spring
7	**	CP7717-15-EPR	O-Ring, EPDM Rubber
8	◆◆	CP23124-PP	Spring Retainer
9	5110266	CP23123-PP	Lock Ring
10	5046270	CP23122-NY	Adjusting Cap, Nylon (Gray)

** Available only in Repair Kit

◆◆: Only Available in Complete Assembly

Hose Reel Components For Hose Reel Assembly (5301342)

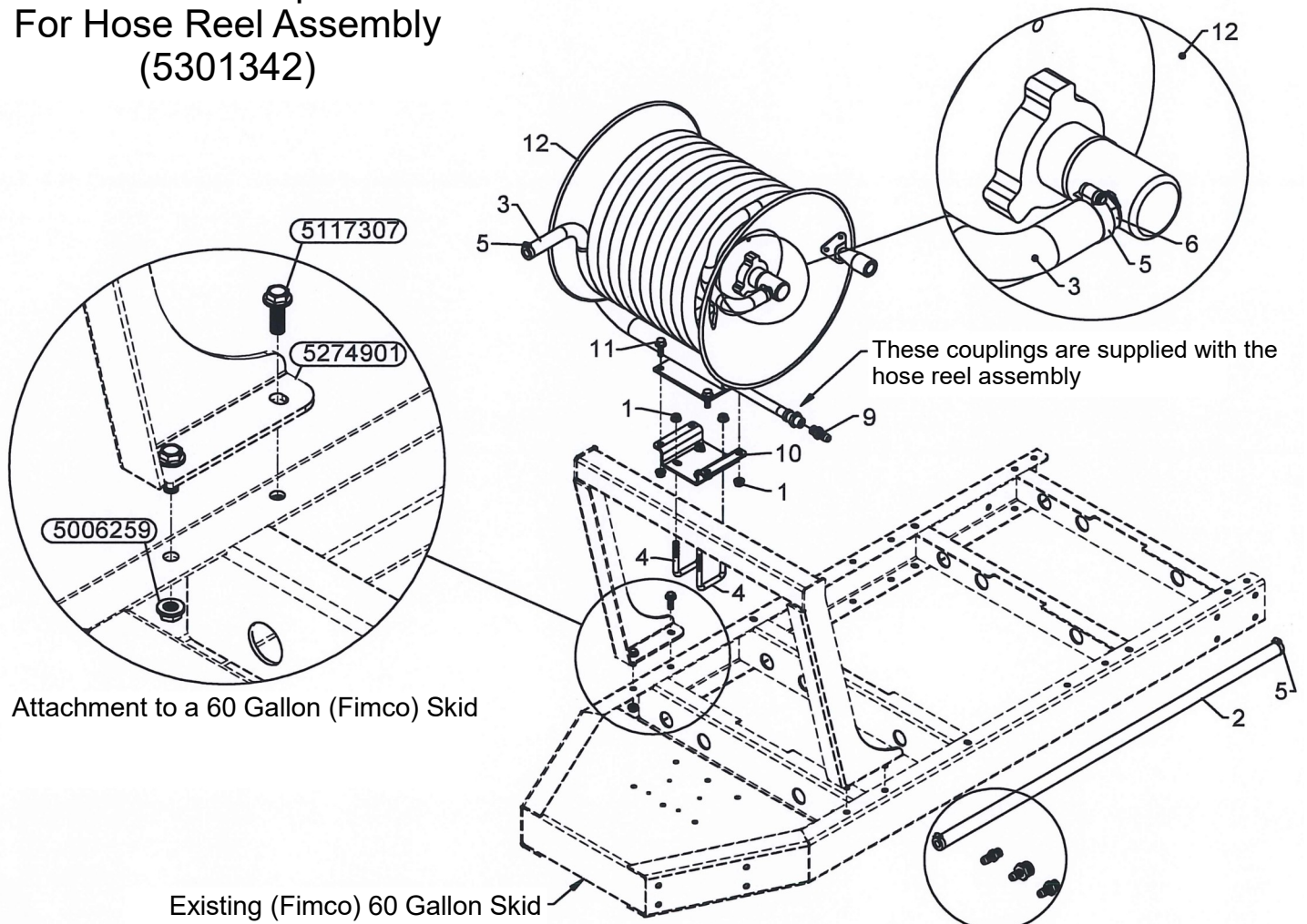

Attachment to a 60 Gallon (Fimco) Skid

Existing (Fimco) 60 Gallon Skid

Ref. #	Part #	Description	Qty.
1	5006259	3/8"-16nc Hex Flanged Whiz Nut, Grade 5	8
2	5000574	Hose, 1/2" x 36"	1
3	5020503	Hose, 1/2"-1 Brd. x 100'	1
4	5034188	Square U-Bolt, 3/8" Dia. x 2-1/8" x 2-7/8"	2
5	5051114	Hose Clamp, 1/2"	4
6	5067052	Steel Fitting, 1/2" MPT x 1/2" HB	1
7	5067125	Poly Fitting, 3/4" MPT x 1/2" HB	1
8	5067131	Poly Fitting, 1/2" MPT x 1/2" HB	1
9	5067136	Poly Fitting, 3/8" MPT x 1/2" HB	2
10	5095281	Hose Reel Mount	1
11	5117307	H.H.C.S. Flanged 3/8"-16nc x 1"	4
12	5277374	Hose Reel, 3500 PSI, 3/8" x 200' Capacity	1

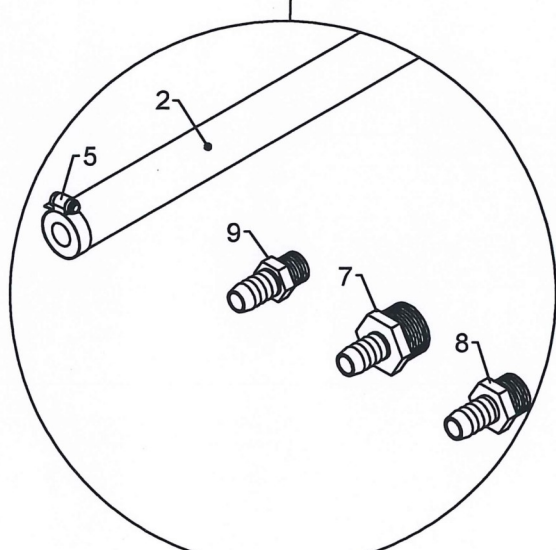

These fittings and hose/hose clamps may or may not be used, depending on what setup you are connecting this hose reel assembly to. Consider these as extra parts, if needed.

NOTES:

Warranty Info

LIMITED WARRANTY FOR NEW FIMCO, IND. EQUIPMENT

WHO MAY USE THIS LIMITED WARRANTY. This limited warranty (the "Limited Warranty") is provided by Fimco, Ind. to the original purchaser ("you") of the Equipment (as defined below) from Fimco, Ind. or one of Fimco, Ind.'s authorized dealers. This Limited Warranty does not apply to any subsequent owner or other transferee of the Equipment. THIS LIMITED WARRANTY GIVES YOU SPECIFIC LEGAL RIGHTS, AND YOU MAY ALSO HAVE OTHER RIGHTS WHICH VARY FROM STATE TO STATE.

WHAT THIS LIMITED WARRANTY COVERS AND FOR HOW LONG. Fimco, Ind. warrants that any new Equipment will be free from defects in material and workmanship for a period of **one (1) year** (homeowner), **90 days** (commercial user), after delivery of the Equipment to you (the "Warranty Period"). The Warranty Period is not extended if Fimco, Ind. repairs or replaces the Equipment.

WHAT IS NOT COVERED BY THIS LIMITED WARRANTY. This Limited Warranty does not apply to: (1) used Equipment; (2) any Equipment that has been altered, changed, repaired or treated since its delivery to you, other than by Fimco, Ind. or its authorized dealers; (3) damage or depreciation due to normal wear and tear; (4) defects or damage due to failure to follow Fimco, Ind.'s operator's manual, specifications or other written instructions, or improper storage, operation, maintenance, application or installation of parts; (5) defects or damage due to misuse, accident or neglect, "acts of God" or other events beyond Fimco, Ind.'s reasonable control; (6) accessories, attachments, tools or parts that were not manufactured by Fimco, Ind., whether or not sold or operated with the Equipment; or (7) rubber parts, such as tires, hoses and grommets.

HOW TO OBTAIN WARRANTY SERVICE. To obtain warranty service under this Limited Warranty, you must (1) provide written notice to Fimco, Ind. of the defect during the Warranty Period and within **thirty (30)** days after the defect becomes apparent or the repair becomes necessary, at the following address: Fimco, Ind., 1000 Fimco Lane, North Sioux City, SD 57049; and (2) make the Equipment available to Fimco, Ind. or an authorized dealer within a reasonable period of time. For more information about this Limited Warranty, please call: **800-831-0027**.

WHAT REMEDIES ARE AVAILABLE UNDER THIS LIMITED WARRANTY. If the conditions set forth above are fulfilled and the Equipment or any part thereof is found to be defective, Fimco, Ind. shall, at its own cost, and at its option, either repair or replace the defective Equipment or part. Fimco, Ind. will pay for shipping and handling fees to return the repaired or replacement Equipment or part to you.

LIMITATION OF IMPLIED WARRANTIES AND OTHER REMEDIES. THE REMEDIES DESCRIBED ABOVE ARE YOUR SOLE AND EXCLUSIVE REMEDIES, AND FIMCO, IND.'S SOLE LIABILITY, FOR ANY BREACH OF THIS LIMITED WARRANTY. TO THE EXTENT APPLICABLE, ANY IMPLIED WARRANTIES, INCLUDING, WITHOUT LIMITATION, THE IMPLIED WARRANTIES OF MERCHANTABILITY AND FITNESS FOR A PARTICULAR PURPOSE, SHALL BE LIMITED IN DURATION TO THE WARRANTY PERIOD, AND THE REMEDIES AVAILABLE FOR BREACH THEREOF SHALL BE LIMITED TO THE REMEDIES AVAILABLE UNDER THIS EXPRESS LIMITED WARRANTY. SOME STATES DO NOT ALLOW LIMITATIONS ON HOW LONG AN IMPLIED WARRANTY LASTS, SO THE ABOVE LIMITATION MAY NOT APPLY TO YOU. IN NO EVENT SHALL FIMCO, IND.'S LIABILITY UNDER THIS LIMITED WARRANTY EXCEED THE ACTUAL AMOUNT PAID BY YOU FOR THE DEFECTIVE EQUIPMENT, NOR SHALL FIMCO, IND. BE LIABLE, UNDER ANY CIRCUMSTANCES, FOR ANY CONSEQUENTIAL, INCIDENTAL, SPECIAL OR PUNITIVE DAMAGES OR LOSSES, WHETHER DIRECT OR INDIRECT. SOME STATES DO NOT ALLOW THE EXCLUSION OR LIMITATION OF INCIDENTAL OR CONSEQUENTIAL DAMAGES, SO THE ABOVE LIMITATION OR EXCLUSION MAY NOT APPLY TO YOU.