

# OWNER'S MANUAL

**Model: TC-17 (5301397)**  
(17 Cubic Foot Steel Trailer Cart)

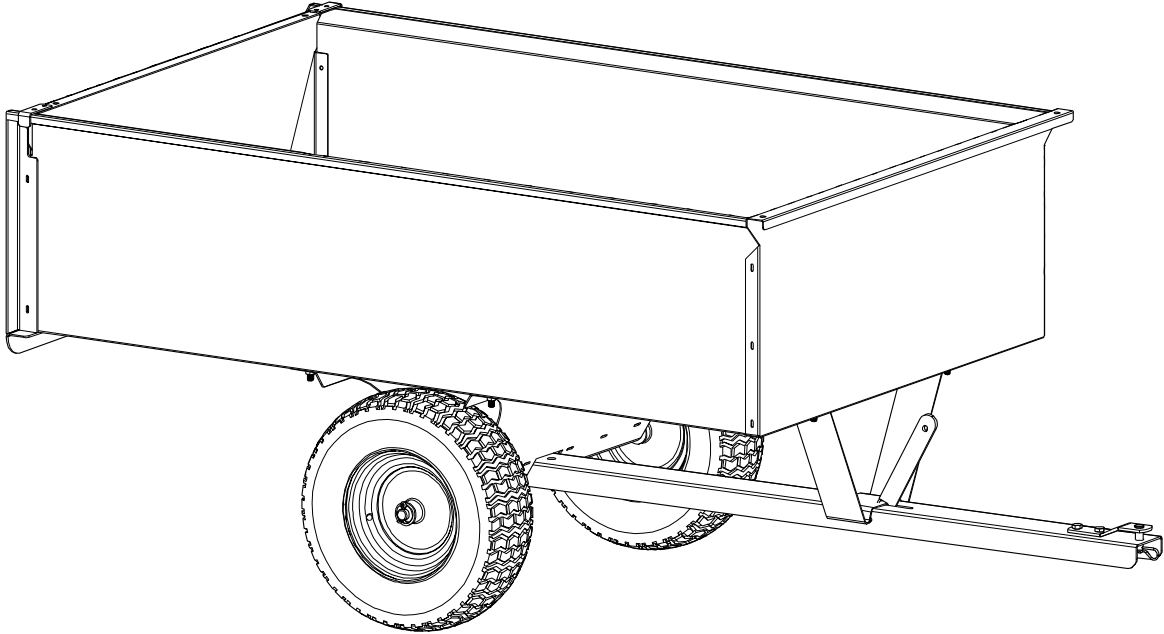

## General Information

Thank you for purchasing this product. The purpose of this manual is to assist you in operating and maintaining your steel cart assembly.

**BEFORE RETURNING THIS PRODUCT  
FOR ANY REASON, PLEASE CALL**

**1-800-831-0027**

MONDAY-FRIDAY, 8:00 AM TO 5:00 PM CST

If you should have a question or experience a problem with your Fimco Industries Product: Visit our website @ [www.fimcoindustries.com](http://www.fimcoindustries.com) or call the Toll free number above. Our technical support representatives will be happy to help you.

In most cases a customer service rep. can resolve the problem over the phone.

To obtain prompt, efficient service, always remember to give the following information....

- Correct Part Description and/or part number
- Model number and Serial Number

Part descriptions and numbers can be obtained from the illustrated parts list section(s) of this manual.

**Retain a copy of your receipt for your unit,  
as it will be required to validate any warranty service.**

**Warranted against manufacturer or workmanship defects from  
date of purchase with copy of receipt:**

**Homeowner Usage: One Year.**

**Commercial Usage: 90 Days.**



**NOTE:** Maximum Speed - 4 MPH

Refer to vehicle's manual for towing instructions.



**WARNING:** To reduce the risk of injury, the user must read and understand the operator's manual before using this product.



**WARNING:** Cancer and Reproductive Harm.

[www.P65Warnings.ca.gov](http://www.P65Warnings.ca.gov)



[www.fimcoindustries.com](http://www.fimcoindustries.com)

1000 FIMCO Lane, P.O. Box 1700, North Sioux City, SD 57049  
Toll Free Phone: 800-831-0027 : Toll Free Fax: 800-494-0440

[5004673

(11/22)]

## Contents

Technical Specifications and Warnings .....	2	Exploded Parts View and Parts List .....	4 - 5
Using Your Dump Cart/Maintenance/Storage .....	2	Dimensions.....	5
Assembly Instructions .....	3	Warranty .....	6

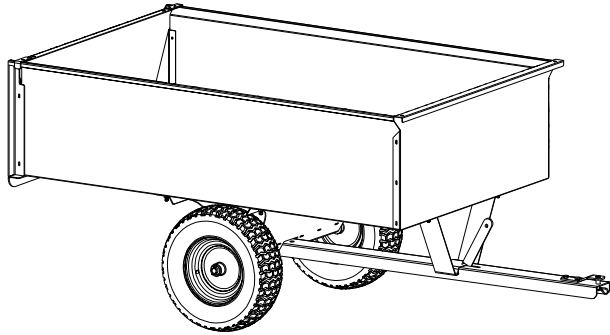

## Model: TC-17 (5301397) (17 Cubic Foot Steel Trailer Cart)

### Technical Specifications

- 1500 lbs. Maximum Capacity  
Approximate Weight of 1 Cu. Ft.:
  - Dirt: 150 lbs.
  - Sand: 125 lbs.
  - Gravel: 110 lbs.
- Maximum Speed: 4 MPH

### Warning: Danger of Improper Use of Cart:

This unit is intended for use only with riding mowers or tractors. It is definitely NOT for highway use, being pulled at high speeds or transporting passengers of any sort. Such use could result in injuries for which we cannot be held responsible.

## WARNING



**Read and Understand the Owner's Manual** completely before using this attachment. Assemble, test and use in accordance to manual instructions.

**Exercise Caution** in vehicle handling when using this attachment to avoid loss of control or overturning.

**Do Not** allow anyone to ride in/on this attachment or with you when operating. Failure to comply could result in severe injury or damage.

**Keep children, bystanders and pets** at a safe distance away while operating this or any attachment.

**Refer to** towing vehicle manual to determine proper towing capacity. Avoid overfilling cart.

**Do Not** exceed 4 MPH. Towing speed should always be slow enough to maintain control. Travel slowly and use caution over rough terrain. Avoid holes, rocks and other hidden hazards.

**Use Care when** loading and unloading. An uneven load in the bed could cause bed to dump quickly.

**When reversing**, carefully back-up straight to avoid jackknifing.

**Do Not** tow this attachment behind a motor vehicle, such as a car or truck.

**Slow down** before turning and do not turn sharply. Use wide turns to ensure attachment follows path of towing vehicle.

**Do Not Use** on steep slopes. A heavy load could cause loss of control or overturn attachment and towing vehicle.

**Reduce towed weight** when operating on slopes.

**Always operate** up and down a slope, never across the face of a slope.

**Slow down** and use extra care on hillsides. Turf conditions can affect vehicle stability.

**Keep all movement on slopes** slow and gradual. Do not make sudden changes in speed, directions or turning. Do not start or stop suddenly when going uphill or downhill.

**Stop on level ground**, set the parking brake and shut off engine before leaving the operator's position for any reason.

**Keep all parts** in good condition and properly installed. Fix damaged or worn parts immediately.

**Caution should be taken** when towing and/or using any attachment. This attachment combined with the weight distribution, turning radius and speed of towing vehicle can result in damage to towing vehicle and/or attachment or severe injury or death, if not used properly.

### Using Your Dump Cart

**To Dump:** Pull latch toward your pulling vehicle. The cart will tilt back to the dump position.

**To Return to Pulling Position:** Push down on the front of the cart body until the latch engages and pedestal secures to the tow bar. Your pulling vehicle's speed should be governed by the weight of the load. The heavier the load, the slower the speed for safe operation.

### Maintenance Instructions:

Check tire pressure at regular intervals. Proper inflation, 30 PSI, will prolong the life of the tires. Wash cart bed after each use to prevent damage to bed or hardware. Unload cart before performing any maintenance.

### Storage:

Store in a dry place. Cart should be stored with bed closed and locked in position.

## Assembly Instructions

Refer to the exploded view and parts list to help identify the parts and follow instructions below for assembly.

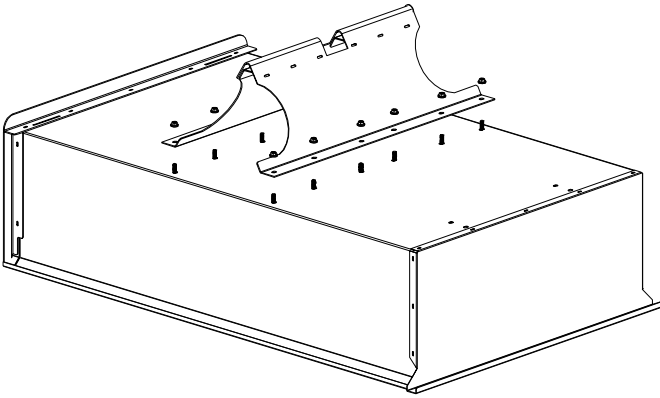

Step 1: Remove tailgate and turn cart body upside down for ease of assembly.

Step 2: Bolt axle housing to cart weldment using the (12) round head machine screws. Secure in place with lock nuts.

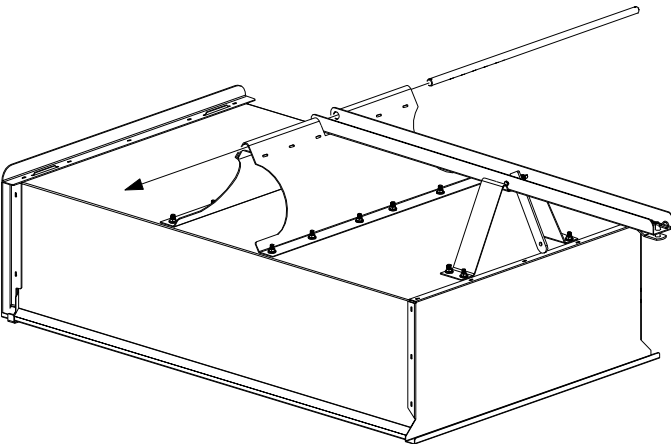

Step 4: Slide the axle through the axle housing and the tongue assembly.

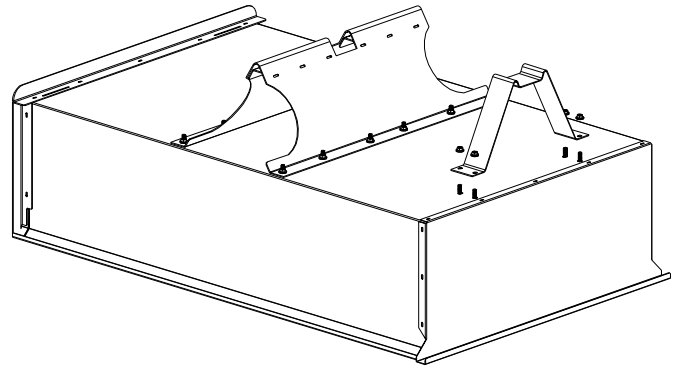
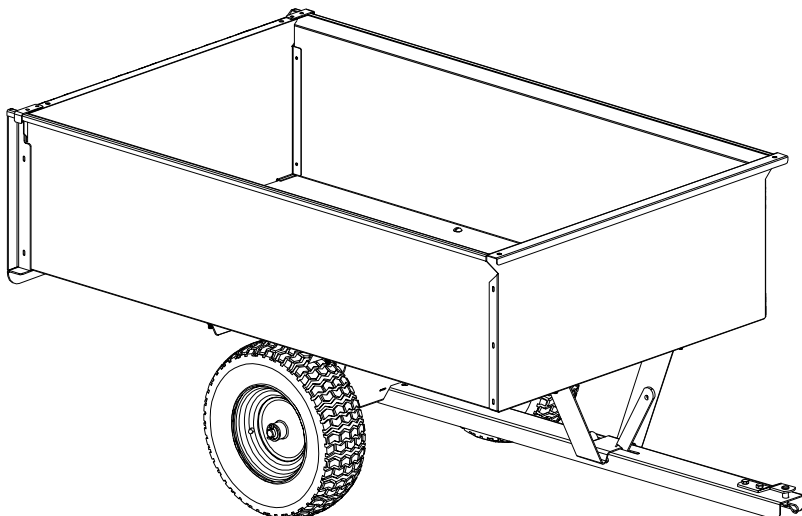

Step 3: Affix yoke brace to the cart body, using (4) round Head machine screws. Secure with lock nuts.

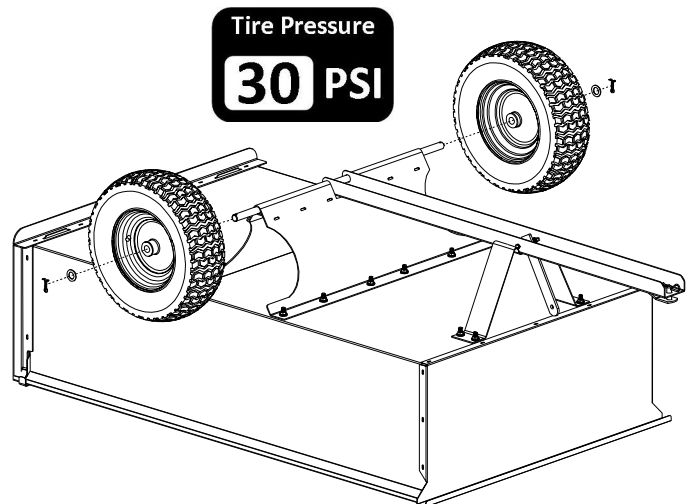

Step 5: Center the axle within the axle housing and place wheel over axle, followed by machine busing on the outside of the wheel.

Step 6: Secure with Cotter Pin.

Repeat procedure for the other side.

Step 7:  
Invert your cart and insert tailgate.

**It is now ready for use.**

Exploded Views: TC-17 (5301397)

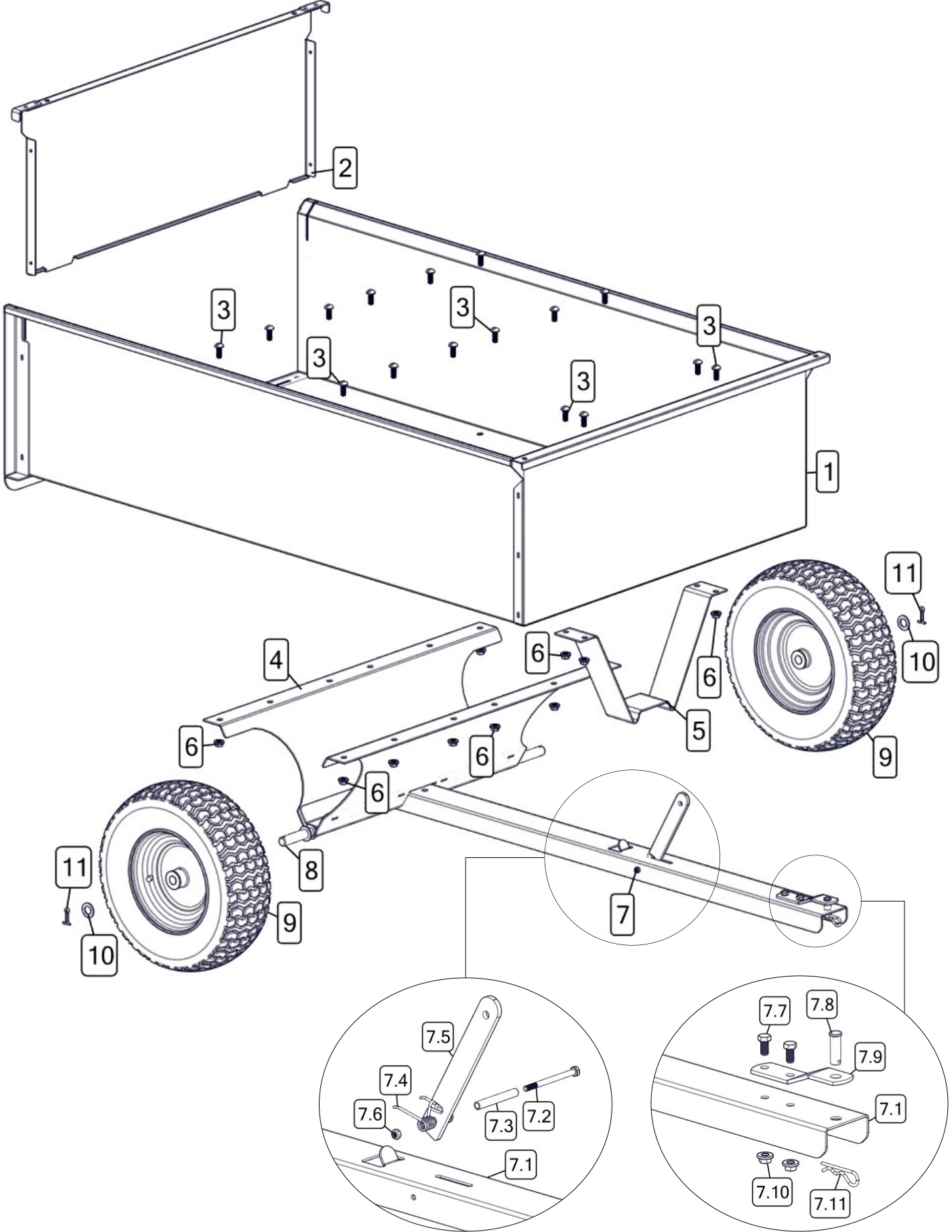

## Parts List: TC-17 (5301397)

Ref. #	Part #	Description	Qty
1	5275049-BLK	17 Cu. Ft. Cart Weldment	1
2	5275059-BLK	Clip to Tailgate 17 CU.	1
3	5117306	3/8-16 x 1.00 Round Head Screw	16
4	5275048-BLK	Axle Housing Weldment	1
5	5037617-BLK	Yoke Brace	1
6	5006259	3/8-16 Serrated Flng Hex Nut	16
7	5275116	Tongue Assembly	1
7.1	5096103-RED	Tongue (17 Cu. Ft. Dump Cart)	1
7.2	5034321	1/4-20 x 3.50 Hex Bolt	1
7.3	5041141	Tongue Latch Bushing	1
7.4	5019262	Tongue Spring, Zinc-Plated	1
7.5	5090008-RED	Dump Cart Latch	1

Ref. #	Part #	Description	Qty
7.6	5006160	1/4-20 Top-Lock Hex Nut	1
7.7	5034099	3/8-16 x 0.75 Hex Bolt	2
7.8	5101268	Clevis Pin, 1/2 x 1.50	1
7.9	5038722-RED	10 Cu. Ft. Dump Cart Hitch	1
7.10	5006259	3/8-16 Serrated Flng Hex Nut	2
7.11	5101065	Hair Pin, #211 x 2.50	1
8	5024100	Axle, 3/4 Dia. x 32 Long	1
9	5021089-SVR	Wheel, 16 x 6.50-8, Turf Tread	2
9.1	5031141	3/4 Inch Wheel Ball Bearing	2
10	5041094	Bushing, 3/4 ID x 1-1/4 OD	2
11	5101086	Cotter Pin, 3/16 x 1.5	2

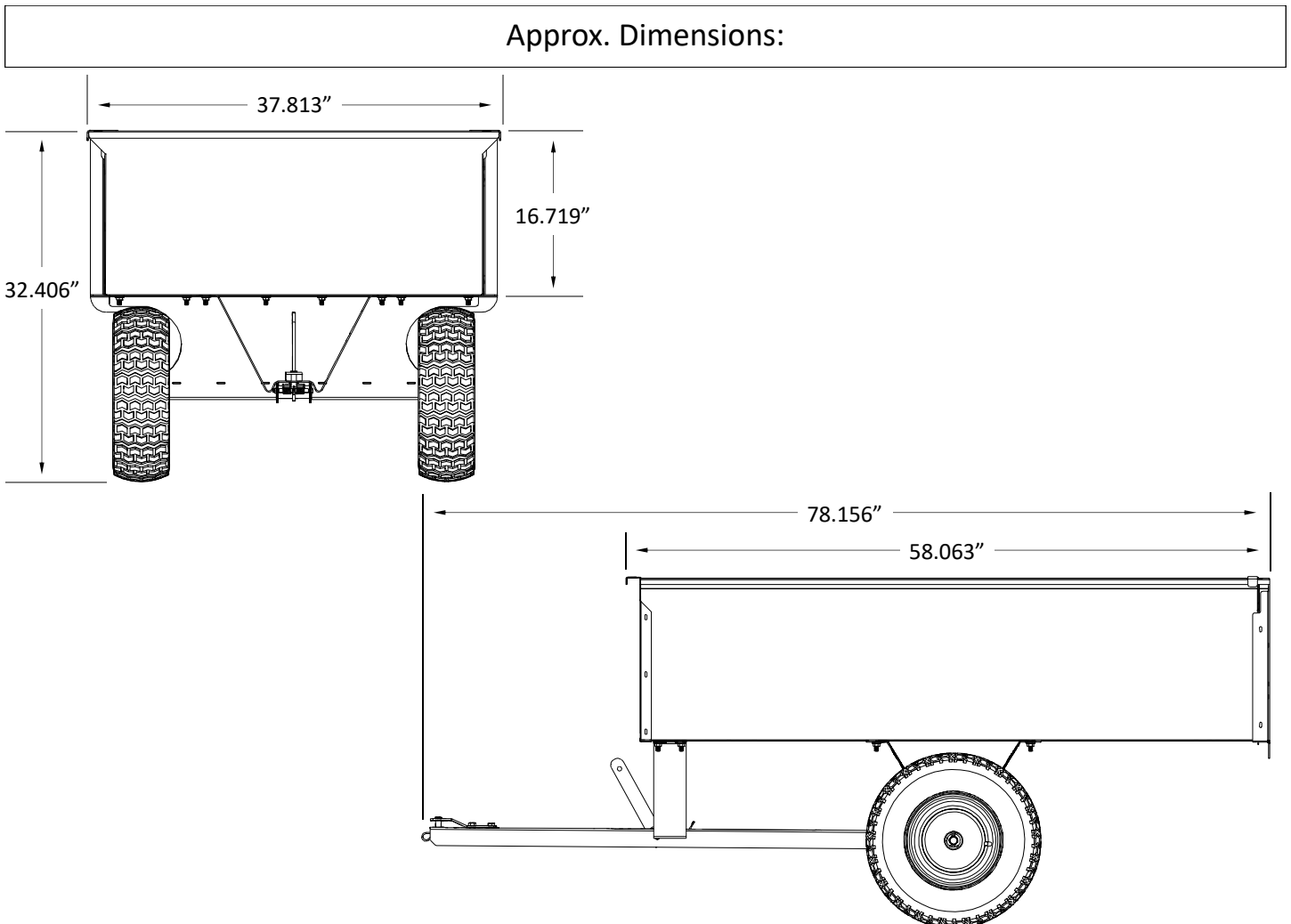

# Warranty

## LIMITED WARRANTY FOR NEW FIMCO, IND. EQUIPMENT

**WHO MAY USE THIS LIMITED WARRANTY.** This limited warranty (the "Limited Warranty") is provided by Fimco, Ind. to the original purchaser ("you") of the Equipment (as defined below) from Fimco, Ind. or one of Fimco, Ind.'s authorized dealers. This Limited Warranty does not apply to any subsequent owner or other transferee of the Equipment. THIS LIMITED WARRANTY GIVES YOU SPECIFIC LEGAL RIGHTS, AND YOU MAY ALSO HAVE OTHER RIGHTS WHICH VARY FROM STATE TO STATE.

**WHAT THIS LIMITED WARRANTY COVERS AND FOR HOW LONG.** Fimco, Ind. warrants that any new Equipment will be free from defects in material and workmanship for a period of **one (1) year** (homeowner), **90 days** (commercial user), after delivery of the Equipment to you (the "Warranty Period"). The Warranty Period is not extended if Fimco, Ind. repairs or replaces the Equipment.

**WHAT IS NOT COVERED BY THIS LIMITED WARRANTY.** This Limited Warranty does not apply to: (1) used Equipment; (2) any Equipment that has been altered, changed, repaired or treated since its delivery to you, other than by Fimco, Ind. or its authorized dealers; (3) damage or depreciation due to normal wear and tear; (4) defects or damage due to failure to follow Fimco, Ind.'s operator's manual, specifications or other written instructions, or improper storage, operation, maintenance, application or installation of parts; (5) defects or damage due to misuse, accident or neglect, "acts of God" or other events beyond Fimco, Ind.'s reasonable control; (6) accessories, attachments, tools or parts that were not manufactured by Fimco, Ind., whether or not sold or operated with the Equipment; or (7) rubber parts, such as tires, hoses and grommets.

**HOW TO OBTAIN WARRANTY SERVICE.** To obtain warranty service under this Limited Warranty, you must (1) provide written notice to Fimco of the defect during the Warranty Period and within **thirty (30)** days after the defect becomes apparent or the repair becomes necessary, at the following address: Fimco, 1000 Fimco Lane, North Sioux City, SD 57049; and (2) make the Equipment available to Fimco or an authorized dealer within a reasonable period of time. For more information about this Limited Warranty, please call: **800-831-0027**

**WHAT REMEDIES ARE AVAILABLE UNDER THIS LIMITED WARRANTY.** If the conditions set forth above are fulfilled and the Equipment or any part thereof is found to be defective, Fimco, Ind. shall, at its own cost, and at its option, either repair or replace the defective Equipment or part. Fimco, Ind. will pay for shipping and handling fees to return the repaired or replacement Equipment or part to you.

**LIMITATION OF IMPLIED WARRANTIES AND OTHER REMEDIES.** THE REMEDIES DESCRIBED ABOVE ARE YOUR SOLE AND EXCLUSIVE REMEDIES, AND FIMCO, IND.'S SOLE LIABILITY, FOR ANY BREACH OF THIS LIMITED WARRANTY. TO THE EXTENT APPLICABLE, ANY IMPLIED WARRANTIES, INCLUDING, WITHOUT LIMITATION, THE IMPLIED WARRANTIES OF MERCHANTABILITY AND FITNESS FOR A PARTICULAR PURPOSE, SHALL BE LIMITED IN DURATION TO THE WARRANTY PERIOD, AND THE REMEDIES AVAILABLE FOR BREACH THEREOF SHALL BE LIMITED TO THE REMEDIES AVAILABLE UNDER THIS EXPRESS LIMITED WARRANTY. SOME STATES DO NOT ALLOW LIMITATIONS ON HOW LONG AN IMPLIED WARRANTY LASTS, SO THE ABOVE LIMITATION MAY NOT APPLY TO YOU. IN NO EVENT SHALL FIMCO, IND.'S LIABILITY UNDER THIS LIMITED WARRANTY EXCEED THE ACTUAL AMOUNT PAID BY YOU FOR THE DEFECTIVE EQUIPMENT, NOR SHALL FIMCO, IND. BE LIABLE, UNDER ANY CIRCUMSTANCES, FOR ANY CONSEQUENTIAL, INCIDENTAL, SPECIAL OR PUNITIVE DAMAGES OR LOSSES, WHETHER DIRECT OR INDIRECT. SOME STATES DO NOT ALLOW THE EXCLUSION OR LIMITATION OF INCIDENTAL OR CONSEQUENTIAL DAMAGES, SO THE ABOVE LIMITATION OR EXCLUSION MAY NOT APPLY TO YOU.