

# OWNER'S MANUAL

## Model: TRL-65-4R-BL (5303640)

(65 Gallon Trailer Sprayer w/127cc Engine, 4-Roller Pump & Boomless Boom Assembly)

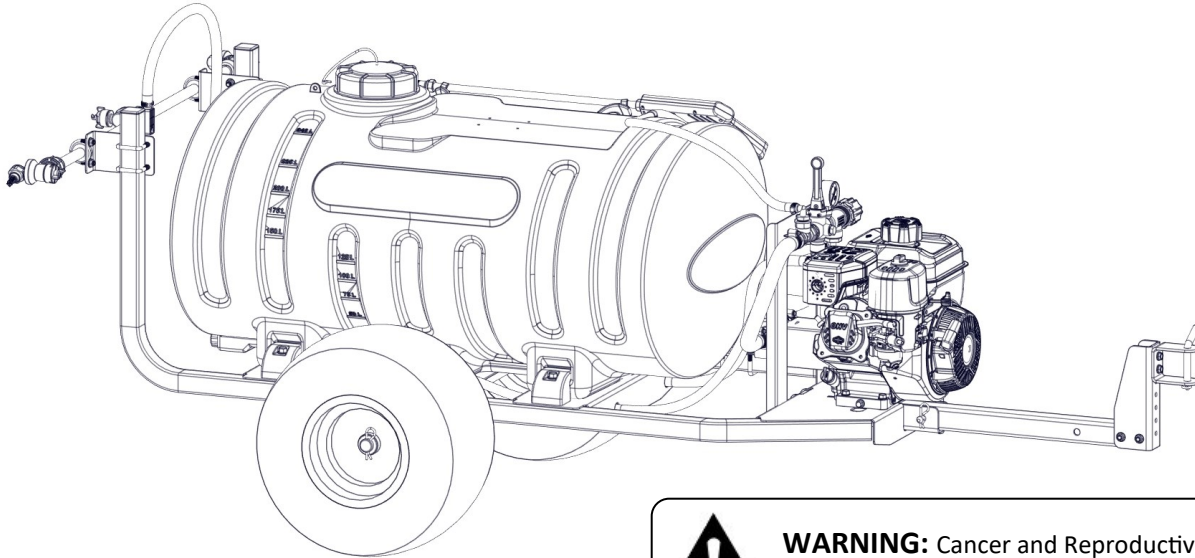

### General Information

Thank you for purchasing this product. The purpose of this manual is to assist you in operating and maintaining your lawn & garden Trailer sprayer.

**BEFORE RETURNING THIS PRODUCT  
FOR ANY REASON, PLEASE CALL**

**1-800-831-0027**

MONDAY-FRIDAY, 8:00 AM TO 5:00 PM CST

If you should have a question or experience a problem with your Fimco Industries Product: Visit our website @ [www.fimcoindustries.com](http://www.fimcoindustries.com) or call the Toll free number above. Our technical support representatives will be happy to help you.

In most cases a customer service rep. can resolve the problem over the phone.

To obtain prompt, efficient service, always remember to give the following information....

- Correct Part Description and/or part number
- Model number and Serial Number

Part descriptions and numbers can be obtained from the illustrated parts list section(s) of this manual.

**Retain a copy of your receipt for your unit, as it will be required to validate any warranty service.**

**Warranted against manufacturer or workmanship defects from date of purchase with copy of receipt:**

**Homeowner Usage: One Year.**

**Commercial Usage: 90 Days.**



**WARNING:** Cancer and Reproductive Harm.  
[www.P65Warnings.ca.gov](http://www.P65Warnings.ca.gov)



**NOTE:** Maximum Speed - Less Than 10 MPH  
Refer to vehicle's manual for towing instructions.



**WARNING:** To reduce the risk of injury, the user must read and understand the operator's manual before using this product.

### **IMPORTANT REMINDER:**

Add proper oil to the engine crankcase and gasoline to the gas tank. Refer to the engine manual for the correct type and amount.

### **\*\*\*WARNING\*\*\***

This product when used can be dangerous and can cause bodily harm, if not properly used or guarded.

**\* STAY AWAY FROM EQUIPMENT  
WHEN IT IS IN OPERATION \***

Read information and the full instructions furnished with the product before installing and operating.



[www.fimcoindustries.com](http://www.fimcoindustries.com)

1000 FIMCO Lane, P.O. Box 1700, North Sioux City, SD 57049  
Toll Free Phone: 800-831-0027 : Toll Free Fax: 800-494-0440

[5195743

(12/22)]

## Contents

Technical Specs.....	2	Roller Pump Exploded View/Parts List.....	9
Sprayer Contents.....	3	Troubleshooting.....	10
Assembly Instructions.....	4 - 6	Sprayer Exploded Views/Parts List.....	11 - 13
Testing and Tank Care.....	7	Sprayer Dimensions.....	13
Operation and Calibration.....	8	Boom Exploded View/Parts List.....	14
Maintenance and Winter Storage.....	9	Warranty.....	16

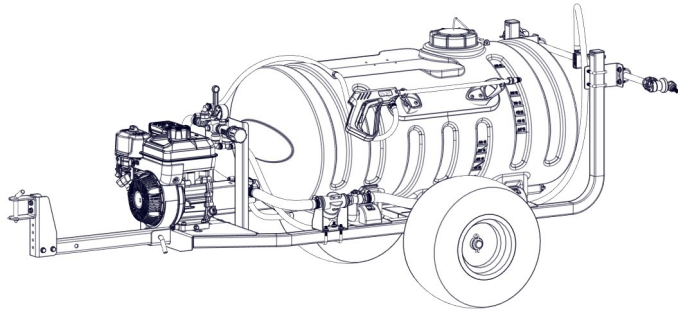

## Model: TRL-65-4R-BL (5303640) (65 Gallon Lawn & Garden Trailer Sprayer w/Boomless Boom Assembly)

### Technical Specifications

- 65 Gal. Corrosion-Resistant Polyethylene Tank
- 127cc Briggs & Stratton Engine
- 4-Roller Pump - 6 GPM
- Deluxe Pistol-Grip Handgun w/25' Handgun Hose
- 18x8.50-8 Turf Tires
- 3-Nozzle Boomless Boom Assembly (36' Spray Coverage)

**Caution: When fully filled with water, this sprayer will weigh approx. 780 lbs..**

**Consult the owner's manual for your vehicle to verify that you are within it's load carrying capacity.**

### ~~~~~IMPORTANT~~~~~

Remove tank lid and be sure the tank is clean and free of any foreign material. Rinse tank out of any tank residue before filling with water to test.

### ~~~~~IMPORTANT~~~~~

It is VERY important to test this sprayer with plain water before actual spraying is attempted. This will enable you to familiarize yourself with the sprayer and check for leaks without the possibility of losing any expensive chemicals.

### ~~~~~WARNING~~~~~



**Read and Understand the Owner's Manual** before using this sprayer. Test and use in accordance to instructions.

**Read and Follow** chemical label instructions and wear protective gear when filling, using, cleaning and servicing the sprayer.

**Exercise Caution** in vehicle handling when towing/hauling a filled sprayer to avoid loss of control or overturning.

**Keep Sprayer and Spray materials** away from other people, children and pets.

**Do Not Turn on Power** to the sprayer, until ready to spray in order to avoid unintentional spray release.

**Do Not Use** on steep slopes. A full sprayer could cause loss of control or overturn sprayer and vehicle.

**Always operate** up and down a slope, never across the face of a slope.

**Keep all movement on slopes** slow and gradual. Do not make sudden changes in speed, directions or turning. Do not start or stop suddenly when going uphill or downhill.

**Stop on level ground**, set the parking brake and shut off engine before leaving the operator's position for any reason.

**Keep all parts** in good condition and properly installed. Fix damaged or worn parts immediately.

**Caution should be taken** when towing and/or using any sprayer. This sprayer combined with the weight distribution, turning radius and speed of vehicle can result in damage to vehicle and/or sprayer or severe injury or death, if not used properly.

**Improper use of this sprayer or handling of chemicals could result in serious injury or illness, or could cause damage to the environment.**

## Contents of Carton

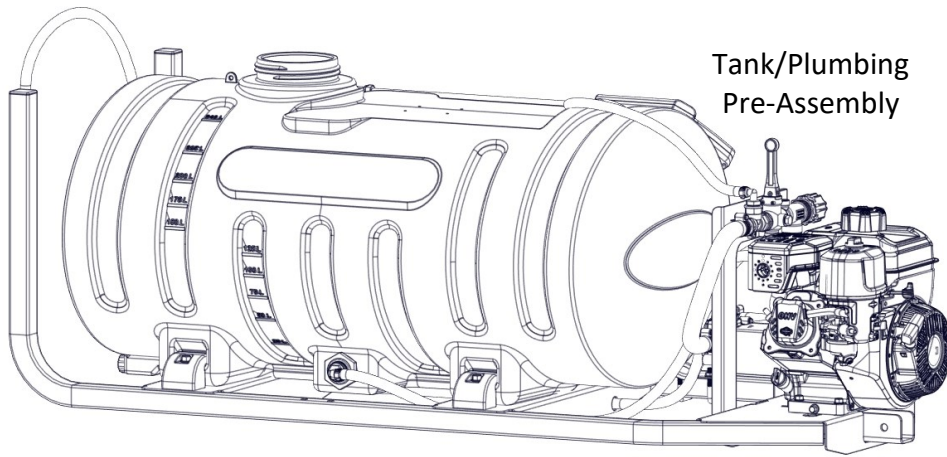

**Tank/Plumbing  
Pre-Assembly**

**Owner's  
Manual**



**Tongue Assembly**

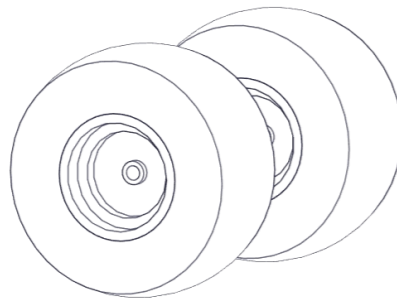

**(2) Wheel  
Assemblies**

**1" Axle Support**

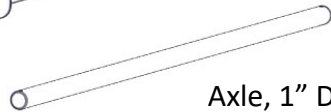
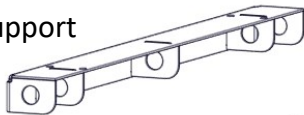

**Axle, 1" Dia. x 38-1/8"**



**Boomless Boom Subassembly**

**End Nozzles**

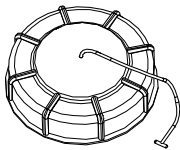

**Tank Lid  
& Lanyard**

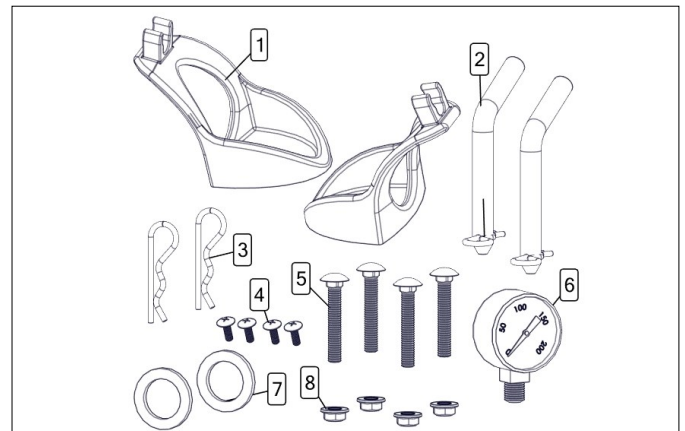

**Contents of 65G TRL Parts Bag (#5025020)**

Ref. #	Part #	Description	Qty
1	5133276	Hose Wrap	2
2	5101202	Bent Clevis Pin (1/2" Dia.)	2
3	5101065	Hair Pin, #211 x 2.50	2
4	5117234	#10-24 x 0.50 PH Truss Head Screw	4
5	5034536	5/16-18 x 2.00 Carriage Bolt	4
6	5167004	Gauge, 0-200 p.s.i. (Dry)	1
7	5041113	Machinery Bushing, 1 1/2" O.D. x 1" I.D. x 10 Ga.	2
8	5006307	5/16-18 Serrated Fling Hex Nut	4

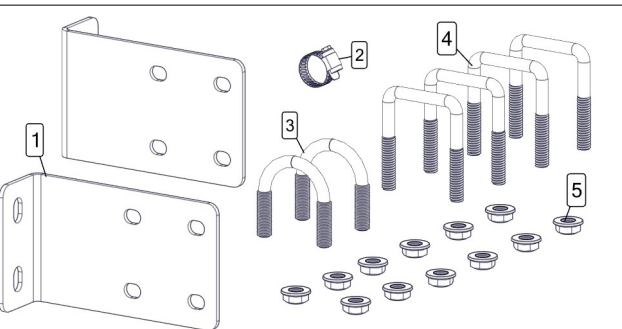

**Contents of Mount Kit Parts Bag (#5281316)**

Ref. #	Part #	Description	Qty
1	5095944-BLK	Trailer Boom Mount	2
2	5051114	Hose Clamp (1/2")	1
3	5034220	5/16-18 x 1.3125 x 1.75 Round U-Bolt	2
4	5034832	5/16-18 x 1.5625 x 2.1875 Square U-Bolt	4
5	5006307	5/16-18 Serrated Fling Hex Nut	12

# Assembly Instructions

Your sprayer has been partially assembled at the factory.

Remove all parts from the box and follow the instructions on pages 4 and 5 to complete assembly of this unit.

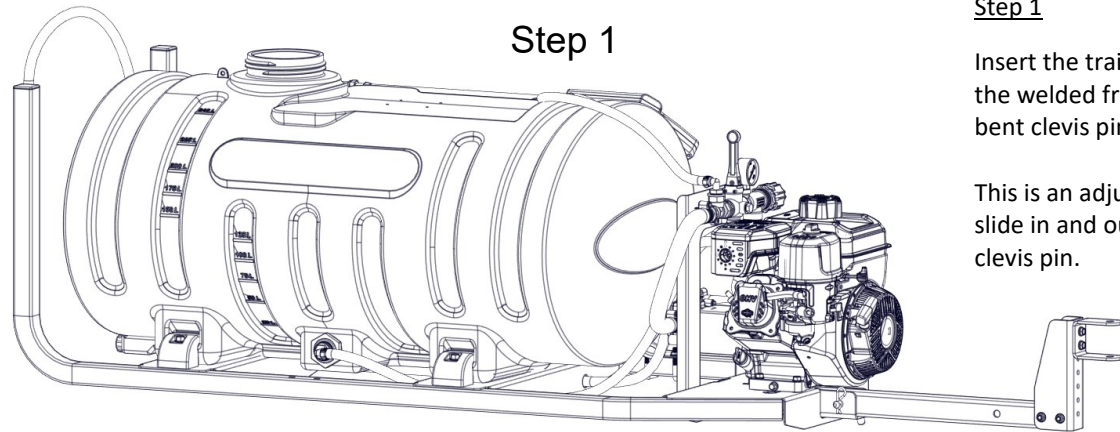

## Step 1

Insert the trailer tongue assembly into the welded frame and secure with the bent clevis pin, as shown.

This is an adjustable tongue, made to slide in and out for storage using the clevis pin.

## Step 2

Mount the axle support to the frame, using the four carriage bolts and hex nuts.

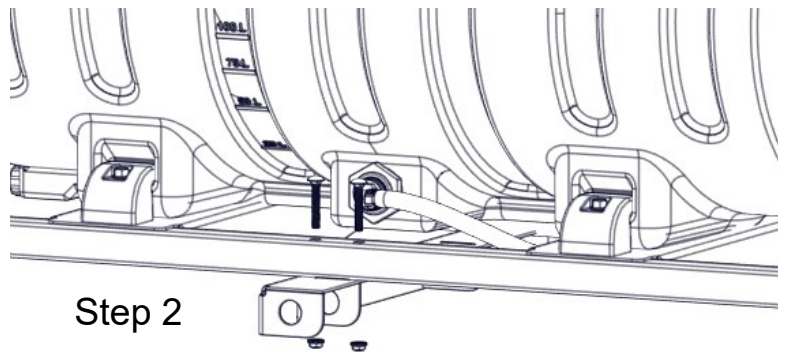

## Step 3

Insert the axle through the holes in the axle support.

Then slide a wheel on to the axle, then the bushing and secure with the cotter pin.

Repeat for the other side.

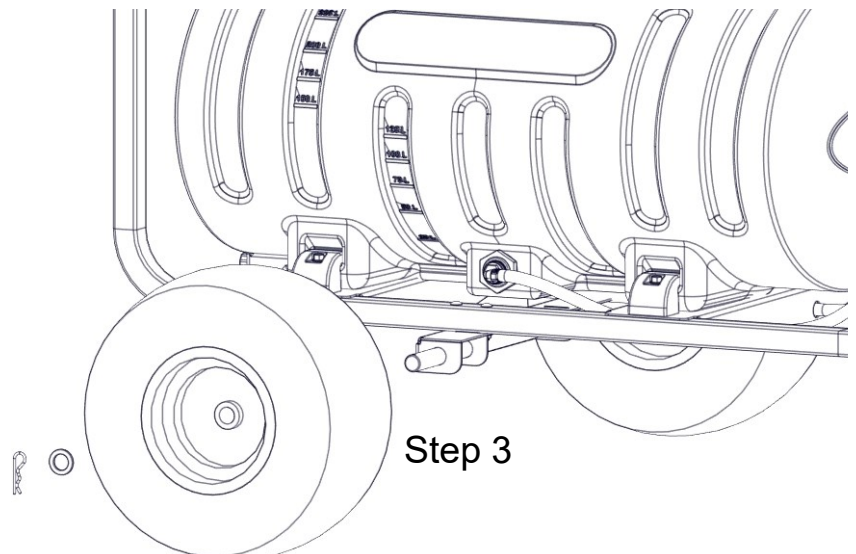

# Assembly Instructions

## Step 4

Attach the trailer boom mounts to the upright arms of the frame tubes and secure with square u-bolts and hex nuts. Be sure to keep them at a level height with each other, see suggested spray height on the exploded boom parts page.

## Step 4

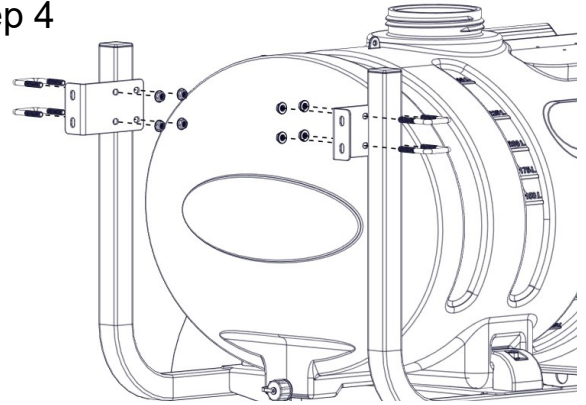

## Step 5

Center the boom tube on the boom mounts and secure in place with the (2) round U-bolts and whiz nuts provided. Make sure the U-bolts are positioned within the grooves of the grommets on the boom tube.

## Step 5

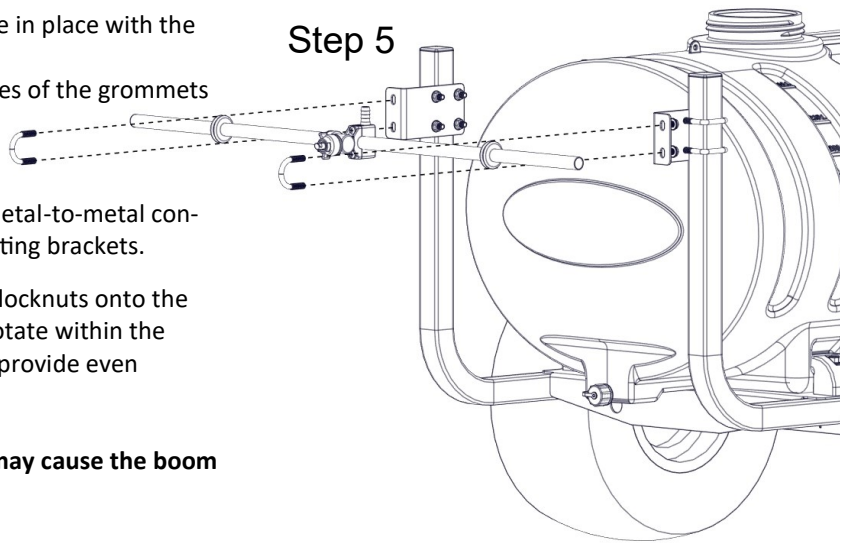

**NOTE:** The purpose of these grommets is to prevent metal-to-metal contact between the U-bolts, boom tube and boom mounting brackets.

The grommets will 'compress' as you tighten the whiz locknuts onto the U-bolts. Tighten just so that the boom tube will NOT rotate within the grommets. Alternate the tightening of the locknuts to provide even pressure on the grommet.

**\*\*DO NOT OVER TIGHTEN the whiz locknuts, as this may cause the boom tube to flatten slightly!**

**See Next Page for proper end nozzle attachment.**

Loosely slide a hose clamp on to the feeder hose, connect the boom feeder hose to the hose barb tee on the nozzle harness and secure with the hose clamp.

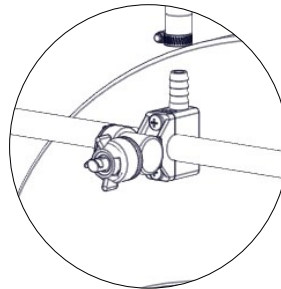

## Step 6

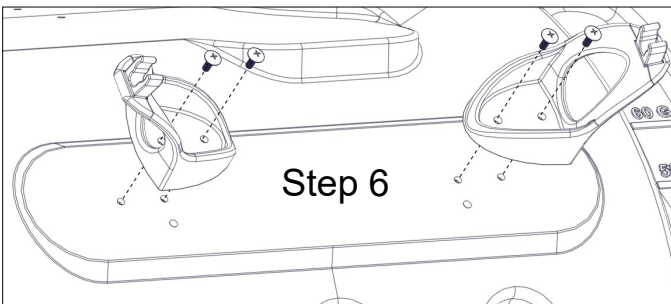

## Step 6

Thread the pressure gauge into the port on the manifold. Hand tight should be sufficient. Attach the hose wraps to the side of the tank, as shown, with 4 screws. Finally, thread the lid on to the tank, if not already done.

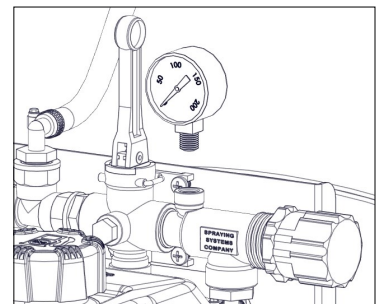

Make sure all hose clamps are tight before testing or spraying for the first time.

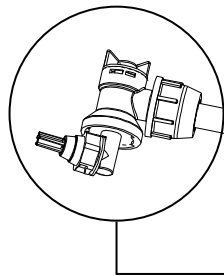

## Step 7 End Nozzle Assembly Procedure For Boomless "Wet" Boom

Your boom will come with the (2) end nozzle assemblies NOT affixed to your boom tube. Follow the instructions below to attach these properly to the boom tube, as shown.

1. First REMOVE O-Ring, Item 2 (#5072517) from the end nozzle body assembly.
2. Start by sliding Item 4, 3, 2 onto the boom tube (Item 1) as shown, leaving about 1/2" to 3/4" between the end of the boom tube and Item 2. Make sure the "Long" portion of Item 3 is facing the nozzle end.
3. Slide the (complete) end nozzle assembly onto the stainless steel boom tube, with somewhat of a "twisting" motion, so that the end face of the boom tube "butts" up against the surface face inside the nozzle body.
4. Now push the "compression olive" (Item 3) against O-ring (Item 2) and slide (both) into the nozzle body opening firmly.
5. Firmly tighten flynut (Item 4) onto threads of nozzle body.

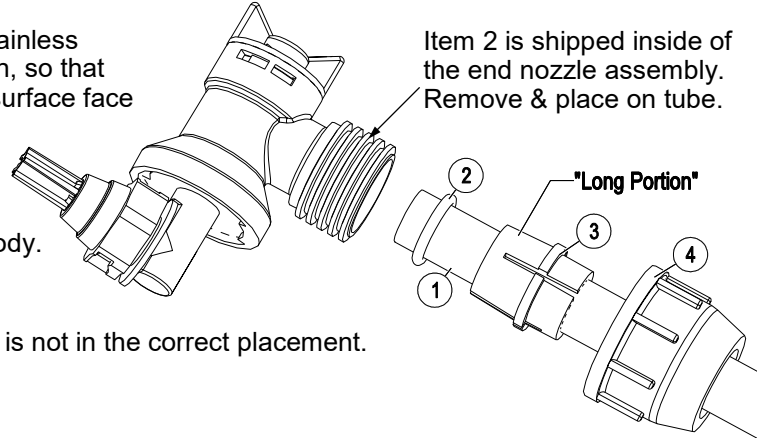

Repeat for other side.

NOTE: If water is shooting back on the boom tube, item 2 is not in the correct placement.

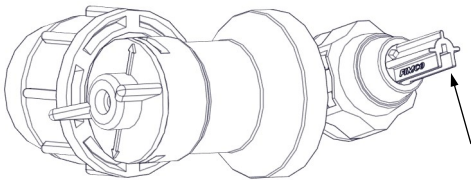

This slot needs to be facing downward in order for the nozzle to spray correctly. If it needs to be adjusted, just loosen the cap and while holding the cap, twist nozzle until it is parallel to the ground.

### End Nozzle Information

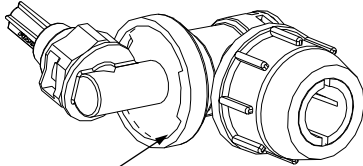

Nozzle mounting stem has a ratcheting motion.

\*\* Each "click" of the ratcheting motion is approx. 15° \*\*

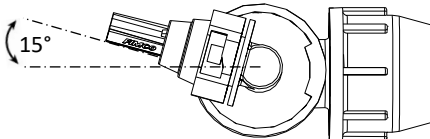

For proper/optimal spray coverage, The nozzle must be at a 15° angle

The 15° angle shown will prevent the outer Nozzles from overlapping with the center nozzle.

### "On/Off" Valve Positions

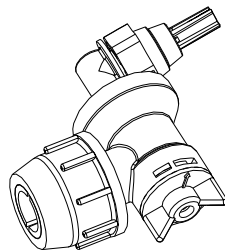

Valve "Open"

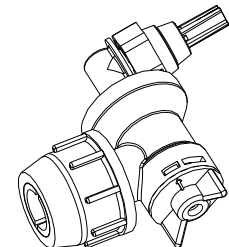

Valve "Closed"

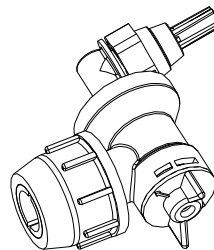

Service Position

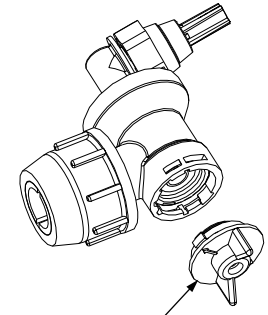

On/Off Valve Knob

Eliminate line pressure, then pull out to check diaphragm condition.

Note: The check valve & diaphragm can fall out during transport, if the knob is not turned to the "ON" or "OFF" position.

**\*\*The Sprayer is now ready to TEST w/plain water before actual use\*\***

**IMPORTANT:** Remove tank lid and be sure the tank is clean and free of any foreign material. Rinse tank out of any tank residue before filling with water to test.

**NOTE:** It is important to test the sprayer with plain water before actual spraying is attempted. This will enable you to check the sprayer for leaks in the plumbing system

#### Testing the Sprayer

1. Fill the tank about 1/2 full with plain water.

**Only fill the tank with what you're going to spray in a day, never leave chemicals sit in tank.**

2. Open the brass valve in the suction line (See Detail A) and allow water to flow to the pump. The valve is located at this point to enable the strainer to be taken apart for cleaning, while solution remains in the tank.

**CAUTION:** Always be sure that water (or solution) has reached the roller pump before starting your sprayer. If the pump is run dry, serious damage to the pump will result. Do not run your sprayer with the boom/handgun line closed AND the bypass line closed. Doing this will damage the pump.

3. It is always best to start the sprayer at little or no pressure. This sprayer is equipped with a spring loaded relief valve. Turn the valve knob out to decrease pressure and in to increase pressure.

The bypass valve is the "pressure control" for the entire plumbing system. The more the valve is open, the lower your line pressure. Almost fully closed provides maximum pressure to your boom and/or handgun. **NEVER run your system with this valve 100% closed.**

**NOTE:** Engine is shipped with no oil. Add proper oil to the engine crankcase and gasoline to the gas tank. Refer to the engine manual for the correct type and amount.

4. You may now start the engine following the engine manufacturers instructions. Let the sprayer run at low pressure until water has reached the handgun and all air has been purged from the system.

The pressure should now be increased to 30-125 P.S.I. Operate the sprayer at this increased pressure for 3-5 minutes, thoroughly testing the unit before adding chemicals.

**Caution:** Care must be taken, being sure the handgun is secured in the operators hand. If this is not done a recoiling action may occur causing damage or personal injury.

Add water to the tank and drive to the starting place for spraying. When you are ready to spray, position booms out for spraying and turn the boom valve to the "on" position. This will start solution spraying from the tips of the boom. The pressure will decrease slightly when the boom is spraying. Adjust the pressure by twisting the gray twist knob on the bypass (pressure relief) valve. Twist 'clockwise' to increase pressure , 'counter-clockwise' to decrease pressure. Read the operating instructions and initially begin spraying by closing the 'bypass' valve and opening the boom line valve. This will enable the air in the line to be eliminated (purged) through all the tips, while building pressure. When everything tests all right (no leaks and good pressure), add the desired chemicals to the mixture and water combination and start your spraying operation. Adjust the pressure and spray as you did in the testing procedure. Conditions of weather and terrain must be considered when setting the sprayer. Do not spray on windy days. Protective clothing must be worn in some cases

**Be sure to read the chemical label(s) before application!**

#### Information About the Sprayer

In this pumping system, solution is drawn from the tank and forced to a planned source, such as boom nozzles or handgun. The pressure is controlled by opening/closing the valve which recirculates solution back into the tank.

#### Priming the pump

To help prime the pump, keep the inlet or suction line as short as possible with a minimum of bends, elbows and kinks. Make sure all connections are tight and do not leak air. Make sure the line strainer is free of debris. If pump does not self-prime, disconnect suction hose, fill with water and reconnect to liquid source. Often a squirt of oil into the ports of the pump will seal clearances and help priming. Facing the pump, the suction port is on your left.

#### Tank Care & Maintenance

**Warning:** Do not use the tank as a container for fuel oils, kerosene, gasoline or any other petroleum distillate product. All polyolefins are softened and permeated by such products. In an enclosed area the vaporization of these materials from the outside surface of the tank could create a dangerous condition.

The tank should not be used as a pressure vessel nor used with chemicals or solutions having a weight of more than 12 pounds per gallon.

Store the tank in a dry dark place when not in use. Storage out of sunlight will prolong the life of the tank.

Do not drop, strike or kick the tank, especially at low temperatures. Tanks become brittle and are subject to cracking at temperatures below 20° Fahrenheit.

Always flush the tank with water and a neutralizing agent at the end of each use, to prevent contamination of solutions.

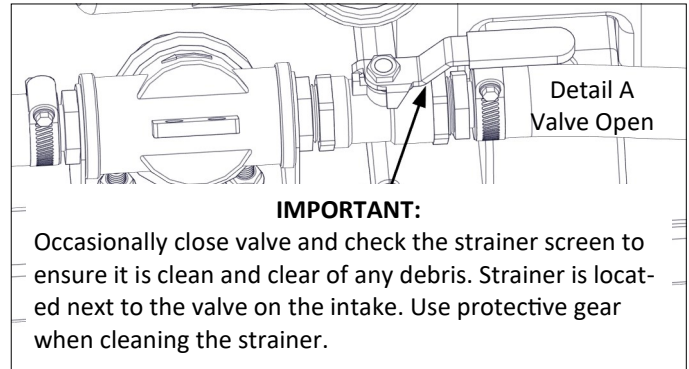

## Operation

Always fill tank 1/2 full with water first and then add the chemical slowly, mixing as you pour the chemical into the tank and fill the rest of the way. You may use the bypass in order to mix the chemical and water.

**Only fill the tank with what you're going to spray in a day, never leave chemicals sit in tank.**

The pumping system draws solution from the tank, through the strainer/filter and to the pump. The pump forces the solution under pressure to the handgun and/or boom nozzles.

- Activate the handgun by squeezing the handle lever
- Rotating the adjustable nozzle tip on the handgun will change the tip pattern from a straight stream to a cone pattern (fine mist)

This sprayer is designed to be towed behind a garden tractor. Check the nozzle pattern by spraying water on a concrete surface.

When spraying with either the boom or the handgun, pressure may be reduced by slowly opening the bypass valve until desired pressure is achieved. Opening the valve decreases pressure, closing the valve increases pressure. When spraying with the boom, the proper method to set the pressure is to open the boom valve completely and if a lower pressure is desired, then slowly open the bypass valve until that pressure is obtained.

For the safest and most efficient chemical application, you will need to calibrate your sprayer using the tip and speed charts. Once you have determined the proper speed and pressure settings, you will need to consult your chemical label for the amount of chemical to be added to the tank. Read the entire label. Use only according to label directions.

## Calibration

Chemical labels may show application rates in gallons per acre, gallons per 1000 square feet or gallons per 100 square feet. You will note that the tip chart shows 3 of these rating systems. Once you know how much you are going to spray, then determine (from the tip chart) the spraying pressure (PSI), and the spraying speed (MPH).

Determining the proper speed of the pulling vehicle can be done by marking off 100, 200 & 300 feet. The speed chart indicates the number of seconds it takes to travel the distances. Set the throttle and with a running start, travel the distances. Adjust the throttle until you travel the distances in the number of seconds indicated by the speed chart. Once you have reached the throttle setting needed, mark the throttle location so you can stop and go again, returning to the same speed.

Add water and proper amount of chemical to the tank and drive to the starting place for spraying.

Note: The same figures are used for 1, 2, or 3 nozzles.									
17½" Spacing									
	Pressure (p.s.i.)	Capacity (g.p.m.) (3 nozzles)	1 MPH	2 MPH	3 MPH	4 MPH	5 MPH	6 MPH	8 MPH
Gallons Per Acre Based on Water	20	1.68	28.0	14.0	9.4	7.0	5.6	4.7	3.5
	30	2.05	34.4	17.2	11.4	8.6	6.9	5.7	4.3
	40	2.40	39.6	19.8	13.2	9.9	7.9	6.6	5.0
Gallons Per 1000 Sq. Ft. Based on Water	20	1.68	0.64	0.32	0.21	0.16	0.13	0.11	0.08
	30	2.05	0.78	0.39	0.26	0.20	0.16	0.13	0.10
	40	2.40	0.90	0.45	0.30	0.23	0.18	0.15	0.12
Gallons Per 100 Sq. Ft. Based on Water	20	1.68	0.064	0.032	0.021	0.016	0.013	0.011	0.008
	30	2.05	0.078	0.039	0.026	0.020	0.016	0.013	0.010
	40	2.40	0.090	0.045	0.030	0.023	0.018	0.015	0.012

\*\* The rate of spray as shown in the chart will remain the same with 1 or 2 Nozzles \*\*  
The only difference will be with the width of the spray swath

Speed Chart			
Speed in M.P.H. (Miles Per Hour)	Time Required in seconds to travel a distance of		
	100 Ft.	200 Ft.	300 Ft.
1.0	68 sec.	136	205
2.0	34	68	102
3.0	23	45	68
4.0	17	34	51
5.0	14	27	41
6.0	11	23	34
7.0	9.7	19	29
8.0	8.5	17	26
9.0	7.6	15	23
10.0	6.8	14	20

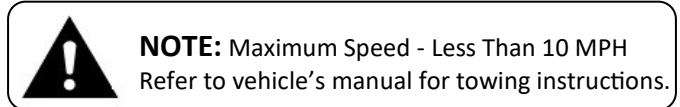

## Using the Boom Nozzles

Four things must be considered before spraying with the boom.

1. How much chemical must be mixed in the tank.
2. Rate of spray (gallons per acre to be sprayed).
3. What pressure (p.s.i.) will be used.
4. Speed traveled (mph) while spraying.

- \* Refer to the chemical label to determine your chemical mixture.
- \* See the tip chart to determine the pressure to be used. The chart will also show the speed used when spraying.
- \* Start the pump and open the valve to the boom nozzles.
- \* Check the spray pattern. Usually you can see the coverage better on a solid concrete surface, such as a driveway.
- \* Approximate height: 33"

- The (3) nozzles are fixed at 17-1/2" spacing
- All (3) nozzles spraying at the same time will allow a maximum coverage of 36 feet
- The center nozzle will spray an 80" swath
- Each of the (3) nozzles has a shutoff valve, so you can shut off each nozzle individually. This may help in achieving the actual coverage needed for your application.



## Maintenance During/After Spraying

Periodically close the suction line valve and check the line strainer and clean the screen. Stop the engine and shut off the valve near the strainer. Remove the bowl and screen portions of the strainer and wash them free from all impurities. You may also drain the tank by uncoupling the suction line near the strainer. Open the valve and pour the contents into another container. Read the chemical label for disposal instructions.

Proper care and maintenance will keep your pump wear at a minimum and will keep it running smoothly and trouble-free for a long time and prolong the life of your sprayer.

After use, fill the sprayer tank part way with water. Start the sprayer and allow the water to pump through the entire plumbing system and nozzles. Drain and then refill half full with plain water, add the recommended amount of good quality tank cleaner such as FIMCO Sprayer Tank Neutralizer and Cleaner. (If no tank cleaner is available, you may substitute dish soap for this step, about 1-2 oz. per gallon). But a neutralizer/cleaner should be used to thoroughly clean the system. Turn sprayer on and circulate through system for 15 minutes and then spray out through handgun nozzle (and boom nozzles if applicable). Refill tank half way with clean water and repeat. Follow the chemical manufacturer's disposal instructions of all wash or rinsing water.

For the boom (if applicable) remove the tips and screens from the nozzle assemblies. Wash these items out thoroughly. Blow the orifice clean and dry. If the orifice remains clogged, clean it with a fine bristle (NOT WIRE) brush or with a toothpick. Do not damage the orifice. Water rinse and dry the tips before storing.

Flush the pump after each use. One of the common causes of faulty pump performance is "gumming" or corrosion inside the pump. This prevents the rollers from moving freely. Flush the pump with a solution that will neutralize liquid pumped. A rust inhibitor can also be squirted into the ports of the pump. Turn shaft several times to draw protective liquid through pump and coat entire inner surface.

**WARNING:** Never pump corrosive or abrasive liquids as these will cause rapid wear or deterioration of body, rotor, shaft and seals in the pump. Never run pump dry. Some chemicals will damage the pump valves if allowed to soak untreated for a length of time! ALWAYS flush the pump as instructed after each use. DO NOT allow chemicals to sit in the pump for extended times of idleness. Failure to follow this warning will void the product warranty.

**Follow the chemical manufacturer's instructions on disposal of all waste water from the sprayer.**

### Winter Storage

Prepare the sprayer for end-of-season storage by draining all water out of your sprayer, paying special attention to the pump, handgun and valve(s). These items are especially prone to damage from chemicals and freezing weather. The sprayer should be winterized before storage by pumping a solution of automotive antifreeze (containing a rust inhibitor) through the entire plumbing system. This antifreeze solution should remain in the plumbing system during the winter months. When spring time comes and you are preparing your sprayer for the spray season, rinse the entire plumbing system out, clearing the lines of the antifreeze solution.

Proper care and maintenance will prolong the life of your sprayer.

It is nearly impossible to drain all of the water from the sprayer and any trapped water can freeze in cold weather and damage parts of the sprayer. Pumping the antifreeze through the system will displace the water and help prevent this damage.

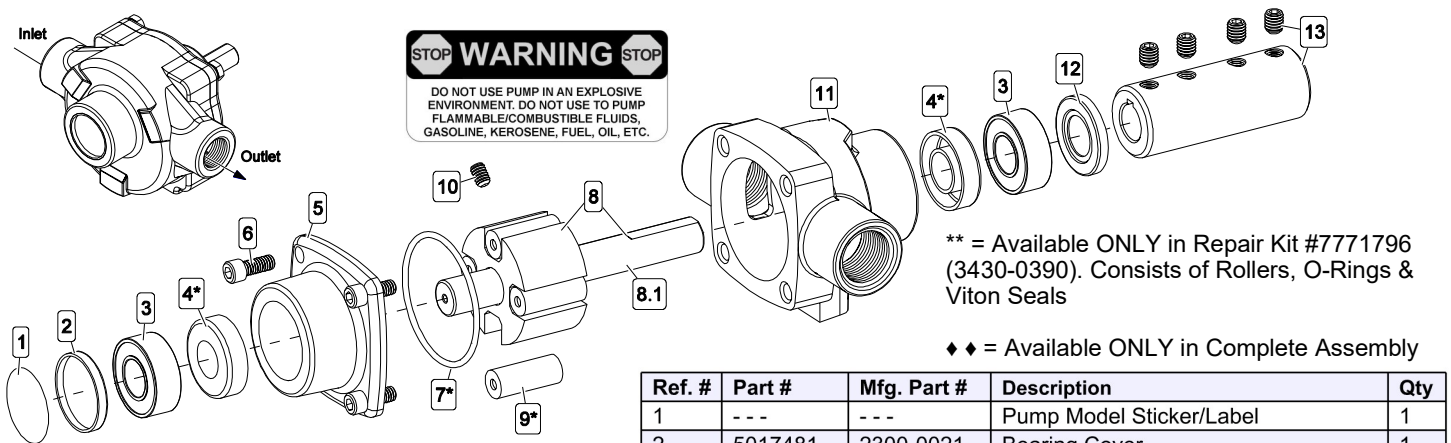

\*\* = Available ONLY in Repair Kit #7771796 (3430-0390). Consists of Rollers, O-Rings & Viton Seals

◆◆ = Available ONLY in Complete Assembly

## Cast Iron 4-Roller Pump Assembly #5273020 (Hypro Mfg. Part #: 4101C-01)

For electric motor drive:  
Output to 9 GPM, Pressure to 150 psi,  
Speed to 1800 RPM, Temperature to 140°F.

For gas engine drive:  
Output to 7 GPM, Pressure to 150 psi,  
Speed to 2600 RPM, Temperature to 140°F

Ref. #	Part #	Mfg. Part #	Description	Qty
1	---	---	Pump Model Sticker/Label	1
2	5017481	2300-0021	Bearing Cover	1
3	5031113	2000-0010	Ball Bearing (Sealed)	2
4*	**	2107-0002	Seal (Viton)	2
5	◆◆	0200-4101C	Endplate (Cast Iron) w/Seal	1
6	◆◆	2220-0018	1/4"-20 x 5/8" Socket Head Cap Screw	4
7*	**	1720-0104	O-Ring Gasket for Endplate	1
8	5172127	0300-4101C	Rotor & Shaft Assembly	1
8.1	0500-6600	0500-6600	Shaft (Only)	1
9*	5112029	1005-0002	Super Roller (Standard)	4
10	◆◆	2230-0002	1/4"-20 x 3/8" Set Screw	1
11	◆◆	0100-4101C	Body (Cast Iron) w/Seal	1
12	5017480	2300-0023	Shaft Bearing Cover	1
13	5005175	1320-0016	Adapter & Kit (Coupler)	1

# Roller Pump General Safety Information

1. Use a pressure relief device on the discharge side of the pump to prevent damage from pressure buildup when the pump discharge is blocked or otherwise closed and the power source is still running.
2. **WARNING:** Never pump flammable or explosive fluids such as gasoline, fuel oil, kerosene, etc. Never use in explosive atmospheres. The pump should be used only with liquids compatible with the pump component materials. Failure to follow this warning can result in personal injury and/or property damage and will void the product warranty.
3. Never pump acids (i.e. acid fertilizer) with Super Rollers!
4. Never run the pump faster than maximum recommended speed.
5. Never pump at pressures higher than the maximum recommended pressure.
6. Never pump liquids at temperatures higher than the recommended maximum temperatures (140°F/60°C).
7. Make certain that the power source conforms to the requirements of your equipment.
8. Provide adequate protection in guarding around the moving parts such as the shaft and pulleys.
9. Disconnect power before servicing.
10. Release all pressure within the system before servicing any component.
11. Drain all liquids from the system before servicing any component.
12. Check all hoses for weak or worn condition before each use. Make certain that all connections are tight and secure.
13. Periodically inspect the pump and the system components. Perform routine maintenance as required.
14. Never operate a gasoline engine in an enclosed area. Be sure the area is well ventilated.
15. Use only pipe, hose and fittings rated for the maximum psi rating of the pump.
16. Never use pump for pumping water or other liquids for human or animal consumption.

## Roller Pump Operation & Maintenance

**WARNING:** Never pump corrosive or abrasive liquids as these will cause rapid wear or deterioration of the body, rotor, shaft and seals in the pump. The pump should be used on with liquids compatible with pump component materials. Never exceed maximum specified rpm and pressure. Never run pump dry. Failure to follow this warning will void the product warranty.

### Priming the Pump:

To help prime the pump, keep the inlet or suction line as short as possible with a minimum of bends, elbows and kinks. Make sure all connections are tight and do not leak air. Make sure line strainer is free of debris. If pump does not self-prime, disconnect suction hose, fill with water and reconnect to liquid source. Often a squirt of oil into the ports of the pump will seal clearance and help priming.

### Care of the Pump:

Proper care and maintenance will keep your pump wear at a minimum and will keep it running smoothly and trouble-free for a long time.

### Flush the Pump After Each Use

**One of the common causes of faulty pump performance is “gumming” or corrosion inside the pump. This prevents rollers from moving freely in their rotor slots. Flush the pump with a solution that will neutralize liquid pumped, mixed according to manufacturer’s directions.**

### To Prevent Corrosion:

After cleaning pump as above, flush it with a 50-50 solution of permanent-type automotive antifreeze (containing a rust inhibitor) and water. A rust inhibitor can also be squirted into the ports of the pump. Turn shaft several times to draw protective liquid through pump and coat entire inner surface. Drain pump and plug ports to keep out air during storage. For short periods of idleness, noncorrosive liquids may be left in the pump, but air must be kept out. Plug ports or seal port connections.

Troubleshooting		
Symptom	Probable Cause(s)	Corrective Action
Pump Does Not Prime	Leak in suction line	Check hose and fittings for leaks and correct
	Obstruction in suction line	Inspect hose for debris or loose inner liner in hose
	Suction hose sucked to bottom or side of tank	Cut a notch or "V" in end of suction hose
	Rollers stuck in pump	Disassemble pump and inspect rollers
	Pump seals leaking air	Replace seals
Loss of Pressure	Clogged suction strainer	Check strainer and clean it regularly
	Kinked or blocked suction hose	Inspect suction hose and repair as necessary
	Air leak in inlet side plumbing	Check hose and connections for leaks Use pipe joint sealant and retighten connections
	Relief valve setting too low or weakened spring	Check relief valve and correct setting
	Faulty Gauge	Replace gauge
	Pump seals leak air	Replace seals
	Nozzle orifices worn	Replace nozzles
Pump worn	Repair pump	
Pump will not turn	Corrosion (rust), scale or residue	Loosen endplate bolts. Squirt oil into ports to help free rotor. Retighten bolts.
	Solid object lodged in pump.	Disassemble pump and remove objects

# Exploded View: TRL-65-4R-BL (5303640)

(See Parts List Next Page)

See Boom  
Assembly  
Page 14 for  
Breakdown & Parts List

See Page 13 for  
Boom Mount  
Detail

See Next Page for  
Exploded View of  
Plumbing Components

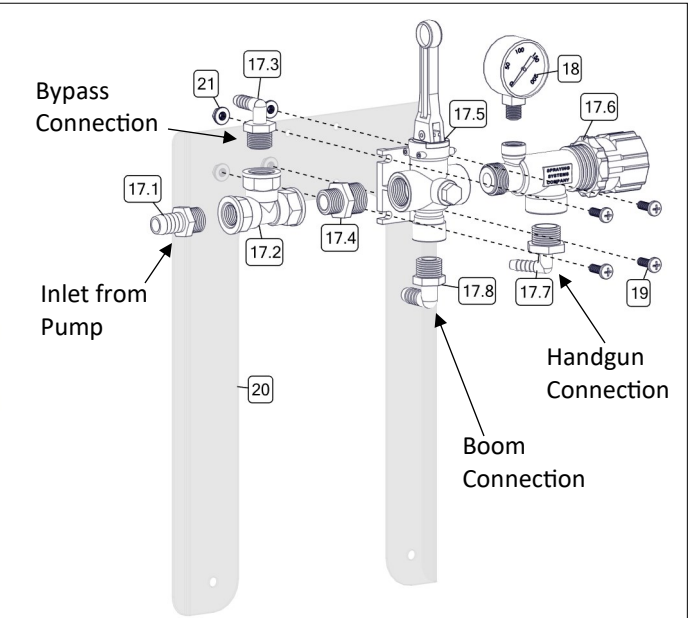
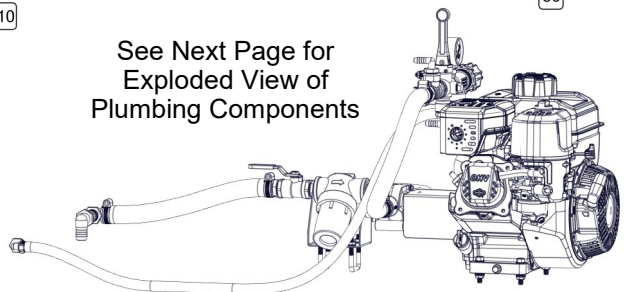
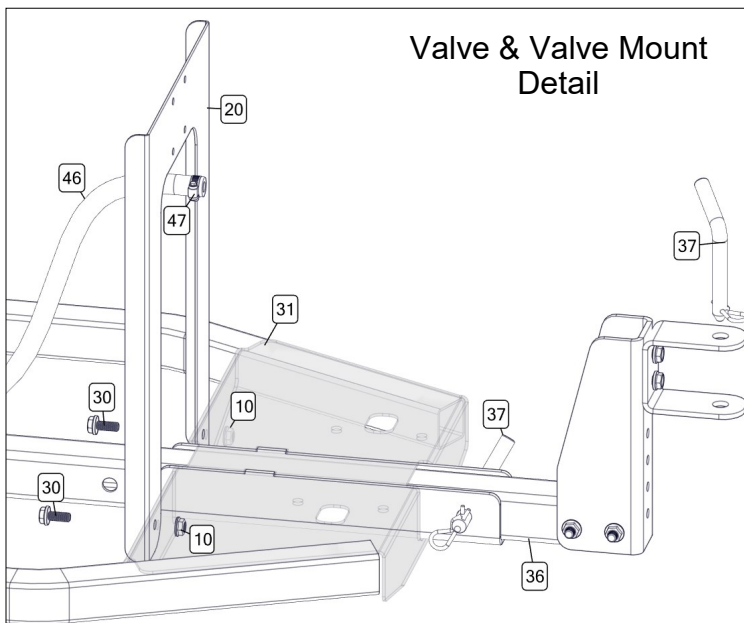
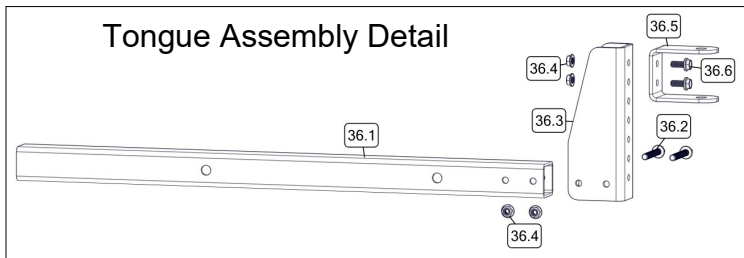
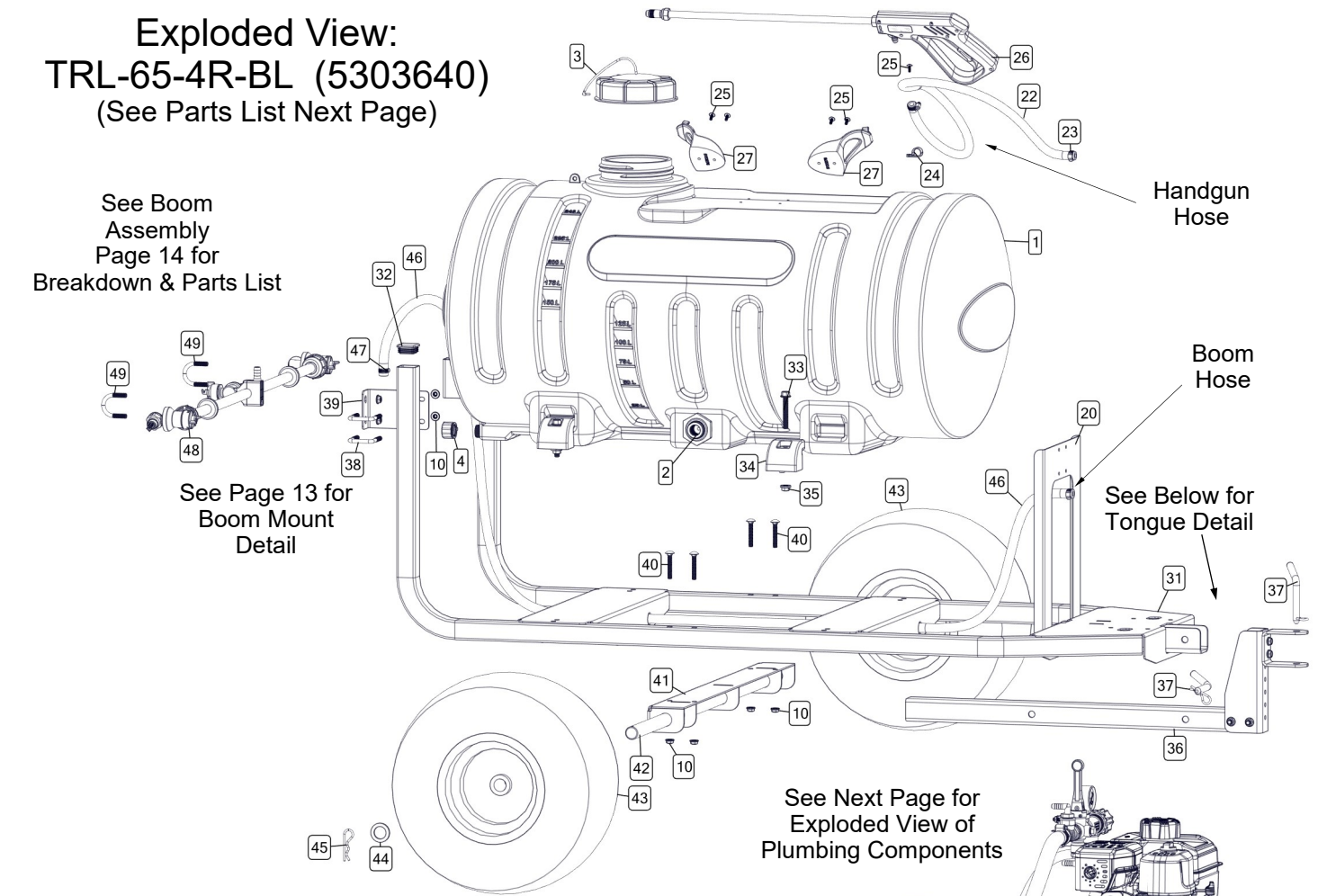

## Parts List: TRL-65-4R-BL (5303640)

Ref. #	Part #	Description	Qty
1	5169361	65 Gallon Elliptical Tank	1
2	5273736	3/4" HD Double Threaded Bulkhead	2
3	5058188	Tank Lid w/Lanyard	1
4	5274373	Drain Plug Cap Assembly	1
5	5010209	Poly Elbow, 3/4" MNPT x 3/4" HB	2
6	5020310	Hose, 3/4"-2 Brd. x 12 1/4"	2
7	5051024	Hose Clamp (3/4")	4
8	5282498	Filter Assembly	1
8.1	5067127	Poly Fitting, 3/4" MNPT x 3/4" HB	2
8.2	5143190	3/4" "T-800" Brass Ball Valve	1
8.3	5011140	Poly Close Nipple, 3/4" MNPT	1
8.4	5116322	3/4" Black Poly Strainer	1
8.4.1	5072229	EPDM Gasket	1
8.4.2	5116323	40 Mesh Screen	1
8.5	5070229-BLK	Filter Mount	1
9	5034832	5/16-18 x 1.5625 x 2.1875 Square U-Bolt	2
10	5006307	5/16-18 Serrated Fling Hex Nut	26
11	5067127	Poly Fitting, 3/4" MNPT x 3/4" HB	1
12	5277100	Engine/Pump Assembly [5.5-4R]	1
12.1	5273020	4-Roller Cast Iron Pump w/Coupler	1
12.1.1	5271757	4-Roller Pump, Cast Iron	1
12.1.2	5005175	Coupler, 5/8" x 5/8"	1
12.1.2.1	5034543	5/16-18 x 0.375 Socket Head Set Screw	4
12.2	5274705	Shield Assembly	1
12.2.1	5120053-BLK	Shield	1
12.2.2	5020320	Hose, 3/8"-2 Brd. x 2"	2
12.3	5016026	Lock Washer, 5/16"	2
12.4	5034108	5/16"-24 x 0.625 Hex Bolt	2
12.5	5152107	127cc B&S 5.50 Gross Torque Engine	1
13	5034638	5/16-18 x 1.50 Fling Hex Bolt (Full Thread)	4
14	5067126	Poly Fitting, 3/4" MNPT x 5/8" HB	1
15	5020077	Hose, 5/8"-1 Brd. x 16"	1
16	5051023	Hose Clamp (5/8")	2
17	5278064	Valve Assembly	1
17.1	5067132	Poly Fitting, 1/2" MNPT x 5/8" HB	1
17.2	5010230	Poly Tee, 1/2" FNPT	1
17.3	5010202	Poly Elbow, 1/2" MNPT x 3/8" HB	1
17.4	5011147	Reducing Nipple, 3/4" MNPT x 1/2" MNPT	1
17.5	5143316	Directo-Valve (AA6B)	1
17.6	5143199	Pressure Relief Valve, (3/4" NPT)	1
17.7	5010206	Poly Elbow, 3/4" MNPT x 3/8" HB	1

Ref. #	Part #	Description	Qty
17.8	5010203	Poly Elbow, 1/2" MNPT x 1/2" HB	1
18	5167004	Gauge, 0-200 p.s.i. (Dry)	1
19	5117325	1/4-20 x 0.75 PH Pan Head Screw	4
20	5070243-BLK	Valve Mount	1
21	5006306	1/4-20 Serrated Fling Hex Nut	4
22	5020527	Hose, 3/8"-1 Brd. x 25 Ft.	1
23	5051144	Hose Clamp (3/8")	4
24	5051122	5/8" Black Nylon Loom Cable Clamp	1
25	5117234	#10-24 x 0.50 PH Truss Head Screw	5
26	5273959	Deluxe Pistol-Grip Handgun w/X-26 Tip	1
26.1	5018331	Brass Handgun Tip (X-26)	1
27	5133276	Hose Wrap	2
28	5020424	Hose, 3/8"-1 Brd. x 36"	1
29	5010206	Poly Elbow, 3/4" MNPT x 3/8" HB	1
30	5117323	5/16-18 x 0.75 Fling Hex Bolt	2
31	5070245-RED	TRL 65 Welded Frame	1
32	5046425	Square Cap, Black (1 1/2" Square Tube)	2
33	5034667	3/8-16 x 2.50 Fling Hex Bolt (Full Thrad)	4
34	5095990	Tank Clamp	4
35	5006259	3/8-16 Serrated Fling Hex Nut	4
36	5013673	Tongue Assembly	1
36.1	5070241-RED	Trailer Tongue	1
36.2	5034642	5/16-18 x 2.50 Fling Hex Bolt (Full Thread)	2
36.3	5038776-BLK	Hitch Bracket	1
36.4	5006307	5/16-18 Serrated Fling Hex Nut	4
36.5	5038777-BLK	Hitch	1
36.6	5117323	5/16-18 x 0.75 Fling Hex Bolt	2
37	5101202	Bent Clevis Pin (1/2" Dia.)	2
38	5034832	5/16-18 x 1.5625 x 2.1875 Square U-Bolt	4
39	5095944-BLK	Trailer Boom Mount	2
40	5034536	5/16-18 x 2.00 Carriage Bolt	4
41	5070246-BLK	1" Axle Support	1
42	5024149-YN	Axle Shaft 1" Dia. x 38.125"	1
43	5021163	18 x 8.5 x 8 Tire w/1" Needle Bearing	2
44	5041113	Bushing, 1 1/2" O.D. x 1" I.D. x 10 Ga.	2
45	5101065	Hair Pin, #211 x 2.50	2
46	5020152	Hose, 1/2"-1 Brd. x 72"	1
47	5051114	Hose Clamp (1/2")	2
48	5275260	Boomless Wet Boom Assembly	1
49	5034220	5/16-18 x 1.3125 x 1.75 Round U-Bolt	2

### Plumbing Components

See Previous Page for:  
Valve Sub-Assembly Exploded View (Item #17)  
See Next Page for:  
Valve/Strainer Assembly Exploded View (Item #8)

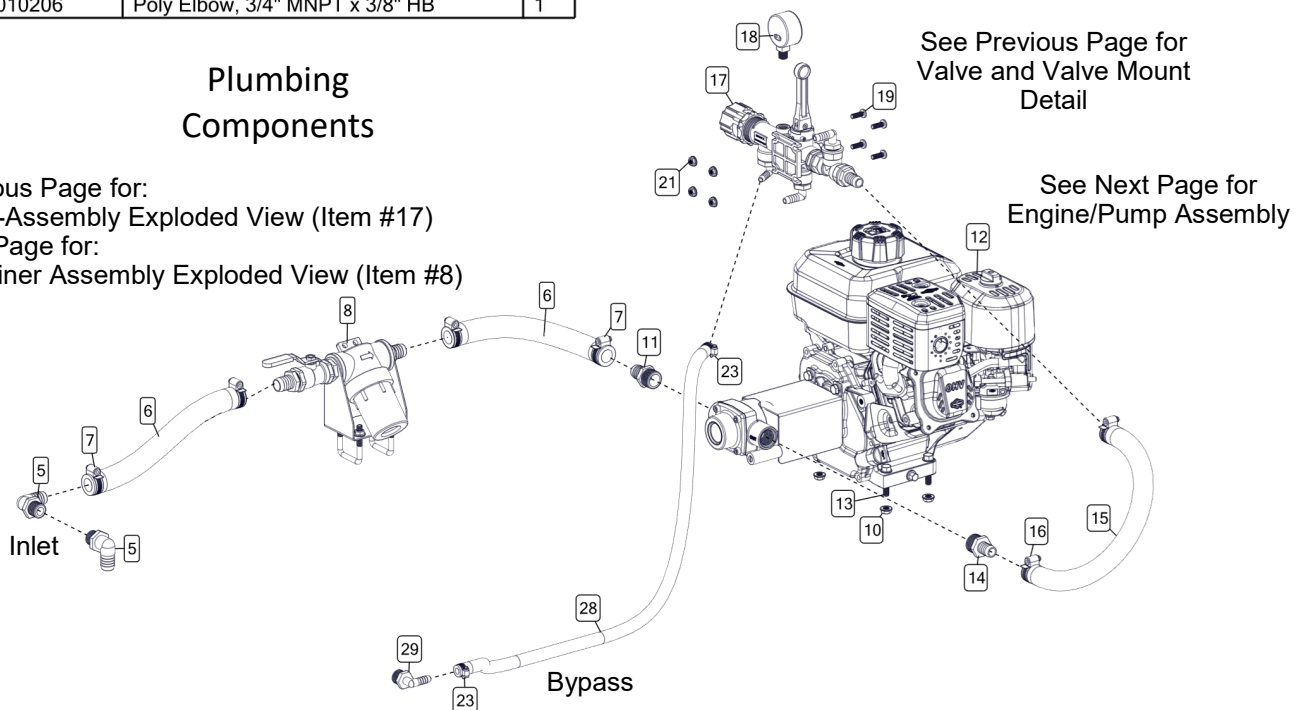

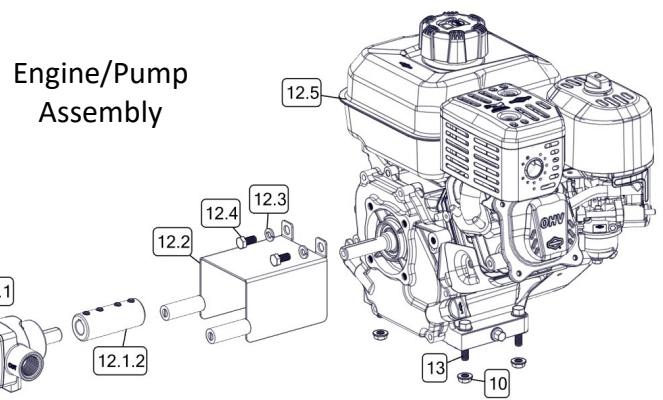
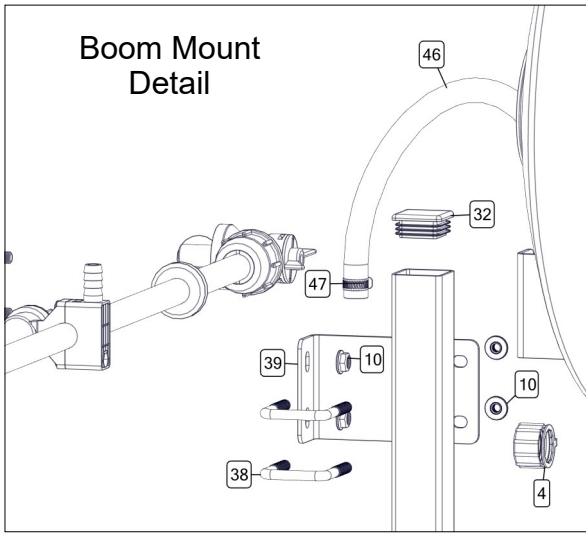

Items #10 & #13 are not part of the engine/pump assembly  
See previous page for part numbers

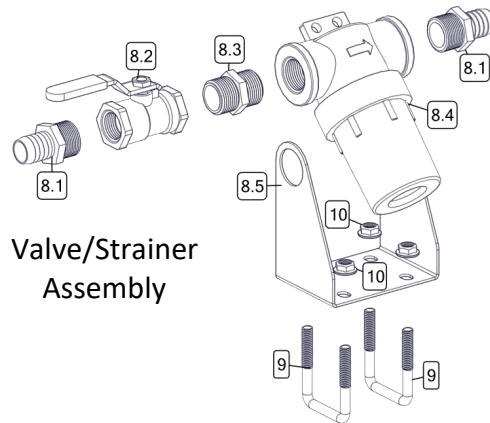
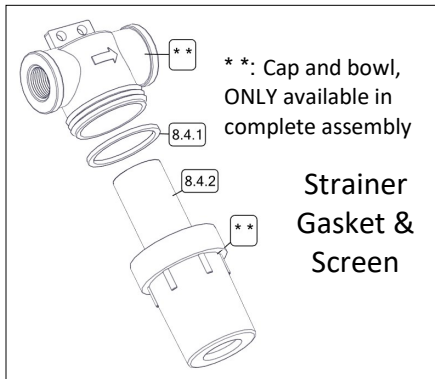

### Approx. Dimensions:

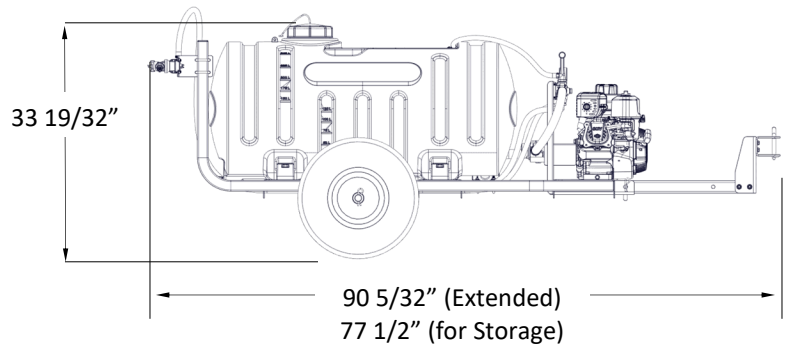
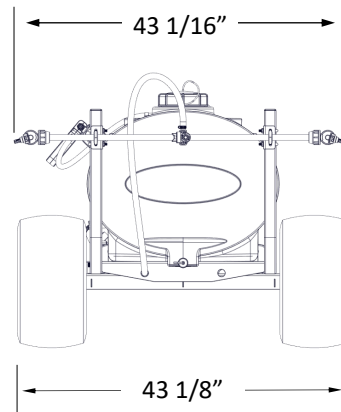
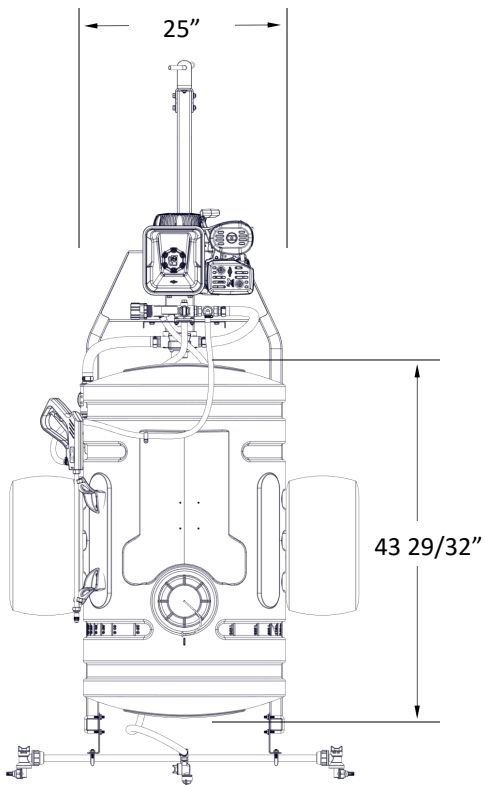

# Boomless "Wet" Boom Assembly

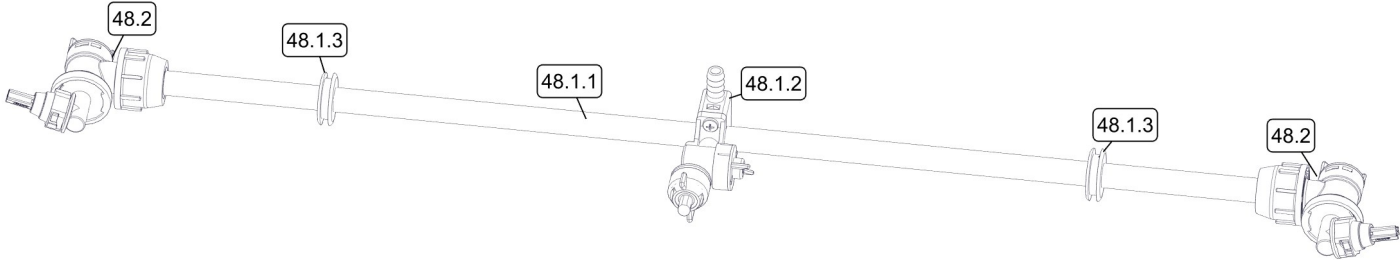

Ref. #	Part #	Description	Qty
48	5275260	"Wet Boom" Assembly	1
48.1	5275712	Wet Boom Sub-Assembly	1
48.1.1	5100316	Boom Tube	1
48.1.2	5275123	Center Nozzle Assembly (Wet Boom)	1
48.1.2.1	5274862	Center Boomless Nozzle Cap w/Gasket	1
48.1.2.2	5018329	Center Spray Tip	1
48.1.2.3	5088024	Valve (On/Off) Knob w/Diaphragm	1

Ref. #	Part #	Description	Qty
48.1.2.3.1	5063255	Diaphragm	1
48.1.3	5075016	Rubber Grommet	2
48.2	5275122	End Nozzle Assembly (Wet Boom)	2
48.2.1	5274861	XT Spray Nozzle, Cap, & O-Ring	1
48.2.2	5088024	Valve (On/Off) Knob w/Diaphragm	1
48.2.2.1	5063255	Diaphragm	1

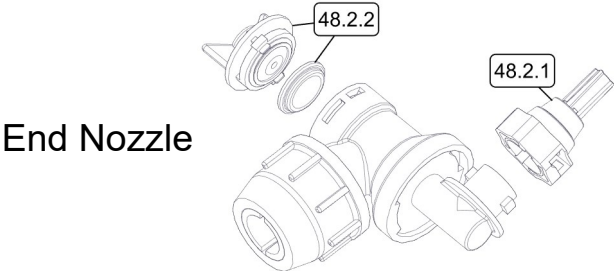
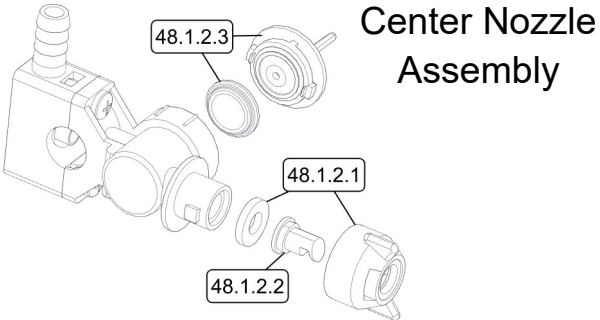

NOTES:

# Warranty

## LIMITED WARRANTY FOR NEW FIMCO, IND. EQUIPMENT

**WHO MAY USE THIS LIMITED WARRANTY.** This limited warranty (the "Limited Warranty") is provided by Fimco, Ind. to the original purchaser ("you") of the Equipment (as defined below) from Fimco, Ind. or one of Fimco, Ind.'s authorized dealers. This Limited Warranty does not apply to any subsequent owner or other transferee of the Equipment. THIS LIMITED WARRANTY GIVES YOU SPECIFIC LEGAL RIGHTS, AND YOU MAY ALSO HAVE OTHER RIGHTS WHICH VARY FROM STATE TO STATE.

**WHAT THIS LIMITED WARRANTY COVERS AND FOR HOW LONG.** Fimco, Ind. warrants that any new Equipment will be free from defects in material and workmanship for a period of **one (1) year** (homeowner), **90 days** (commercial user), after delivery of the Equipment to you (the "Warranty Period"). The Warranty Period is not extended if Fimco, Ind. repairs or replaces the Equipment.

**WHAT IS NOT COVERED BY THIS LIMITED WARRANTY.** This Limited Warranty does not apply to: (1) used Equipment; (2) any Equipment that has been altered, changed, repaired or treated since its delivery to you, other than by Fimco, Ind. or its authorized dealers; (3) damage or depreciation due to normal wear and tear; (4) defects or damage due to failure to follow Fimco, Ind.'s operator's manual, specifications or other written instructions, or improper storage, operation, maintenance, application or installation of parts; (5) defects or damage due to misuse, accident or neglect, "acts of God" or other events beyond Fimco, Ind.'s reasonable control; (6) accessories, attachments, tools or parts that were not manufactured by Fimco, Ind., whether or not sold or operated with the Equipment; or (7) rubber parts, such as tires, hoses and grommets.

**HOW TO OBTAIN WARRANTY SERVICE.** To obtain warranty service under this Limited Warranty, you must (1) provide written notice to Fimco, Ind. of the defect during the Warranty Period and within **thirty (30)** days after the defect becomes apparent or the repair becomes necessary, at the following address: Fimco, Ind., 1000 Fimco Lane, North Sioux City, SD 57049; and (2) make the Equipment available to Fimco, Ind. or an authorized dealer within a reasonable period of time. For more information about this Limited Warranty, please call: **800-831-0027**.

**WHAT REMEDIES ARE AVAILABLE UNDER THIS LIMITED WARRANTY.** If the conditions set forth above are fulfilled and the Equipment or any part thereof is found to be defective, Fimco, Ind. shall, at its own cost, and at its option, either repair or replace the defective Equipment or part. Fimco, Ind. will pay for shipping and handling fees to return the repaired or replacement Equipment or part to you.

**LIMITATION OF IMPLIED WARRANTIES AND OTHER REMEDIES.** THE REMEDIES DESCRIBED ABOVE ARE YOUR SOLE AND EXCLUSIVE REMEDIES, AND FIMCO, IND.'S SOLE LIABILITY, FOR ANY BREACH OF THIS LIMITED WARRANTY. TO THE EXTENT APPLICABLE, ANY IMPLIED WARRANTIES, INCLUDING, WITHOUT LIMITATION, THE IMPLIED WARRANTIES OF MERCHANTABILITY AND FITNESS FOR A PARTICULAR PURPOSE, SHALL BE LIMITED IN DURATION TO THE WARRANTY PERIOD, AND THE REMEDIES AVAILABLE FOR BREACH THEREOF SHALL BE LIMITED TO THE REMEDIES AVAILABLE UNDER THIS EXPRESS LIMITED WARRANTY. SOME STATES DO NOT ALLOW LIMITATIONS ON HOW LONG AN IMPLIED WARRANTY LASTS, SO THE ABOVE LIMITATION MAY NOT APPLY TO YOU. IN NO EVENT SHALL FIMCO, IND.'S LIABILITY UNDER THIS LIMITED WARRANTY EXCEED THE ACTUAL AMOUNT PAID BY YOU FOR THE DEFECTIVE EQUIPMENT, NOR SHALL FIMCO, IND. BE LIABLE, UNDER ANY CIRCUMSTANCES, FOR ANY CONSEQUENTIAL, INCIDENTAL, SPECIAL OR PUNITIVE DAMAGES OR LOSSES, WHETHER DIRECT OR INDIRECT. SOME STATES DO NOT ALLOW THE EXCLUSION OR LIMITATION OF INCIDENTAL OR CONSEQUENTIAL DAMAGES, SO THE ABOVE LIMITATION OR EXCLUSION MAY NOT APPLY TO YOU.